



## ISTITUTO NAZIONALE DI RICERCA METROLOGICA Repository Istituzionale

Absolute frequencies of H<sup>13</sup>C<sup>14</sup>N hydrogen cyanide transitions in the 1.5- $\mu$ m region with the saturated spectroscopy and a sub-kHz scanning laser

*Original*

Absolute frequencies of H<sup>13</sup>C<sup>14</sup>N hydrogen cyanide transitions in the 1.5- $\mu$ m region with the saturated spectroscopy and a sub-kHz scanning laser / Hrabina, Jan; Hosek, Martin; Rerucha, Simon; Cizek, Martin; Pilat, Zdenek; Zucco, Massimo; Lazar, Josef; Cip, Ondrej. - In: OPTICS LETTERS. - ISSN 0146-9592. - 47:21(2022), pp. 5704-5707. [10.1364/OL.467633]

*Availability:*

This version is available at: 11696/77881 since: 2023-10-17T16:00:03Z

*Publisher:*

Optica Publishing Group

*Published*

DOI:10.1364/OL.467633

*Terms of use:*

This article is made available under terms and conditions as specified in the corresponding bibliographic description in the repository

*Publisher copyright*

(Article begins on next page)



# Optics Letters

## Absolute frequencies of $\text{H}^{13}\text{C}^{14}\text{N}$ hydrogen cyanide transitions in the 1.5- $\mu\text{m}$ region with the saturated spectroscopy and a sub-kHz scanning laser

JAN HRABINA,<sup>1</sup> MARTIN HOSEK,<sup>1</sup> SIMON RERUCHA,<sup>1,\*</sup> MARTIN CIZEK,<sup>1</sup> ZDENEK PILAT,<sup>1</sup> MASSIMO ZUCCO,<sup>2</sup> JOSEF LAZAR,<sup>1</sup> AND ONDREJ CIP<sup>1</sup>

<sup>1</sup>Institute of Scientific Instruments of the CAS (ISI), Kralovopolska 147, 61264 Brno, Czech Republic

<sup>2</sup>INRIM Istituto Nazionale di Ricerca Metrologica, Strada delle Cacce 91, Torino, 10135, Italy

\*Corresponding author: res@isibrno.cz

Received 20 June 2022; revised 6 October 2022; accepted 12 October 2022; posted 12 October 2022; published 28 October 2022

The wide span and high density of lines in its rovibrational spectrum render hydrogen cyanide a useful spectroscopic media for referencing absolute frequencies of lasers in optical communication and dimensional metrology. We determined, for the first time to the best of our knowledge, the molecular transitions' center frequencies of the  $\text{H}^{13}\text{C}^{14}\text{N}$  isotope in the range from 1526 nm to 1566 nm with  $1.3 \times 10^{-10}$  fractional uncertainty. We investigated the molecular transitions with a highly coherent and widely tunable scanning laser that was precisely referenced to a hydrogen maser through an optical frequency comb. We demonstrated an approach to stabilize the operational conditions needed to maintain the constantly low pressure of the hydrogen cyanide to carry out the saturated spectroscopy with the third-harmonic synchronous demodulation. We demonstrated approximately a forty-fold improvement in the line centers' resolution compared to the previous result.

© 2022 Optica Publishing Group under the terms of the [Optica Open Access Publishing Agreement](#)

<https://doi.org/10.1364/OL.467633>

**Introduction.** Two decades ago, the hydrogen cyanide (HCN) molecule emerged among spectroscopic media suitable for referencing the lasers' optical frequencies in the 1550-nm bands. It brought some interesting features as an alternative to commonly used isotopes of acetylene. The absorption lines' wavelength band is significantly wider than that of acetylene, and it particularly fits the most widely used C-band in the wavelength division multiplexing in optical fiber communications. The spectrum of HCN isotope  $\text{H}^{13}\text{C}^{14}\text{N}$   $2\nu_3$  band contains more than 50 rovibrational transitions, shown in Fig. 1, useful for spectroscopic referencing the lasers' optical frequencies, provided that the absolute frequencies of the transitions are precisely determined.

The first thorough study [1] determined the frequencies of absorption line centers with the uncertainty of  $\approx 15$  MHz (which translates to a fraction uncertainty of  $8 \times 10^{-8}$ ). More recent and the most exhaustive study so far [2] delivered more accurate data reaching the fraction uncertainty of  $5 \times 10^{-9}$  and added

the characterization of a pressure-induced shift and Doppler broadening. These works used linear spectroscopy to determine the center of absorption lines, which is, however, influenced by the Doppler background. The use of saturated absorption spectroscopy can achieve a significant improvement, such as, for example, with the acetylene where the uncertainties fall below  $1 \times 10^{-11}$  for the  $^{13}\text{C}_2\text{H}_2$  isotope [3].

The activities related to the latter study, carried out by NIST [2], might have brought the reception and recognition of HCN among the established spectroscopic media. Consequently, several commercial manufacturers started producing cells, and later on, HCN found its way to applications beyond optical communications.

In this paper, we demonstrate the feasibility of an approach to systematically measure the line centers' frequencies and other characteristics with (estimated) fractional uncertainty below  $1.3 \times 10^{-10}$  level. Then we present a comparison to previously published data, where our measurement revealed a systematic deviation from previous measurements.

**Aims and challenges.** Our effort was motivated by an application in dimensional metrology, namely the optical absolute distance measurement with frequency scanning interferometry (FSI) [5,6]. In single-wavelength interferometry, the fractional uncertainty of laser optical frequency, i.e., the ratio of the absolute uncertainty of the optical frequency (i.e., laser linewidth) to nominal optical frequency, translates to an equal uncertainty contribution in the length measurement  $u_c = u_\nu/\nu$ . The effect is more pronounced in the multi-wavelength absolute measurement (such as the FSI) where the uncertainties propagates (for two wavelengths) as  $u_c = (u_{\nu_1} + u_{\nu_2})/(\nu_1 - \nu_2)$ , i.e., the ratio of the sum of the linewidths to the difference of the optical frequencies. For example, with two lines at 1535 and 1550 nm, with uncertainty of  $u_{\nu_1} = u_{\nu_2} = 1$  MHz ( $5 \times 10^{-9}$ ) used for the inference of absolute distance, would contribute  $3 \times 10^{-7}$  to the uncertainty of the length measurement. This uncertainty has two major components: (a) the precision of the line center resolution; and (b) the uncertainty of line center frequency. Our effort aims to tackle the latter.

Surprisingly, an atlas of precisely measured centers by the saturated absorption spectroscopy of hyper-fine hydrogen cyanide

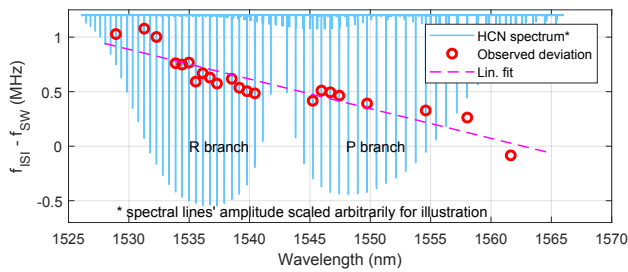

**Fig. 1.** Frequencies of the line centers measured with saturated spectroscopy ( $\nu_{ISI}$ ) compared to published data ( $\nu_{SW}$ ) [2]. The “HCN spectrum” shows the hydrogen cyanide  $H^{13}C^{14}N$   $2\nu_3$  rotational–vibrational band spectrum obtained by scanning a tunable laser and measuring the laser intensity transmitted through an HCN cell with an interaction length of 120 cm and filled to a pressure of 267 Pa (2 Torr  $\pm 10\%$ ); the rolling ball filter [4] was used to remove the signal background.

transitions was still not developed, although primary time standards [7] and optical atomic clocks [8] with relative stability higher than  $10^{-16}$  are available now, and optical frequency combs [9] allow the transfer of such stability to any wavelength in the visible and infrared part of the spectrum. To date, “many narrow lines” have been observed in [10], which reported saturated spectroscopy using a cell placed inside a cavity to build up the necessary pump power but without determining the center frequencies. The insular measurement of the P27 line took place using a similar setup in [11], and the observation of the single R7 line’s Lamb dip using an HCN-filled photonic fiber was reported in [12].

We identified a likely reason why any complex investigation did not occur: we found it challenging to maintain the HCN in stable conditions (in terms of pressure and observed line profile intensity) over a prolonged period when the HCN pressure is kept low ( $\approx$  several Pa). We attributed this effect partially to extensive adsorption and desorption of HCN molecules to gas cell walls, while we assume other effects are still present.

**Methods.** We developed an experimental apparatus, shown in Fig. 2, which allowed us to investigate the line centers’ frequencies of HCN with high precision and absolute accuracy. Three principal parts of the setup were: (a) the widely tunable laser referenced to an optical frequency comb; (b) the vacuum system optimized for the HCN fine-resolution pressure control; and (c) the optical arrangement for saturated spectroscopy. For each investigated line, we used the precise control of the laser’s optical frequency to scan over the line profile, record the amplitude profile of the third-harmonic error signal, and detect its zero crossing, which corresponds to the center frequency.

**Highly coherent scanning laser.** The optical setup was powered by the continuously tunable extended cavity diode laser (CTL) that features a mode-hop-free tuning range from 1510 nm to 1630 nm (CTL 1550, TOPTICA Photonics AG). The CTL’s optical frequency was locked to a selected tooth of the optical frequency comb (OFC) using optical mixing and an in-house developed digitally controlled frequency offset lock, which incorporated a direct digital synthesizer (18-bit resolution) and a fast phase-locked loop unit (450-kHz bandwidth; based on AD9956 chip). This scheme allows us to precisely control the CTL’s output frequency and also narrow the linewidth of the emission spectral profile from the initial  $\approx 300$ -kHz down to the  $\approx 100$ -Hz level. The OFC itself was optically referenced to a

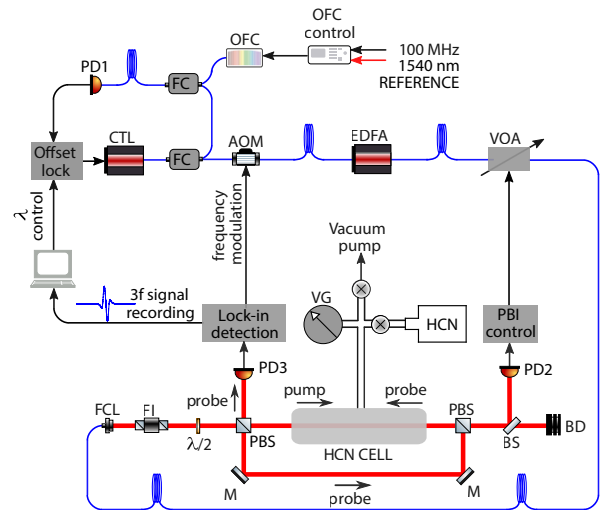

**Fig. 2.** Experimental arrangement. Optical frequency comb (OFC), continuously tuneable laser (CTL), Faraday isolator (FI), acousto-optical modulator (AOM), Er-doped fiber amplifier (EDFA), voltage-controlled optical attenuator (VOA), photodetectors (PD), polarizing beam splitters (PBS), mirrors (M), beam sampler (BS), beam dump (BD), vacuum gauge (VG), fiber couplers (FC), fiber collimator (FCL), probe beam intensity (PBI).

laser that was stabilized to an ultra-narrow linewidth optical cavity at 1540 nm. The repetition frequency of OFC (250 MHz) was disciplined by an H-maser [13]. Its absolute frequency is maintained by continuous tracking to a global navigation satellite system (GNSS) time through a time transfer receiver instrument [14] (DICOM GTR50), and non-periodic comparisons with the  $^{40}Ca^{+}$  ion optical clock [15]. With this arrangement, the absolute frequency of the CTL was well known with  $10^{-13}$  accuracy and controllable down to the  $10^{-15}$  level.

**Vacuum system with pressurized absorption cell.** The vacuum part of the setup consisted of the absorption cell, reservoir with HCN gas, vacuum gauge, and turbomolecular vacuum pump. The body of the 40-cm-long absorption cell was made of stainless steel equipped with a vacuum flange, enabling interconnection to the vacuum system. The cell’s optical windows were made of fused silica and glued to the cell body by vacuum-compatible glue. The amount of gas could be precisely dosed by a needle valve from the reservoir filled with  $H^{13}C^{14}N$  (Wavelength References, Inc.), and the pressure inside the cell was monitored with a capacitance vacuum gauge. The vacuum gauge offset was zeroed before each filling of the cell to keep the absolute scale of the gauge stable and repeatable.

To mitigate the low-pressure effects (such as the adsorption/desorption of HCN molecules to/from the cell body), the inside of the cell was activated by perfusion with ozonized air for 90 minutes, with  $\approx 50$  mg/h of ozone. Subsequently, the cell was filled with a 1% solution of chlorotrimethylsilane (Aldrich,  $>98\%$  by GC) in methanol (Penta chemicals, p.a.) and incubated for 90 minutes at room temperature. The solution was then discarded, and the cell was thoroughly washed with pure methanol, blown dry with filtered air, and simultaneously heated to approximately  $50^{\circ}C$  with a hot air gun.

**Saturated spectroscopy setup.** The investigation of the HCN absorption lines used a saturated spectroscopy optical setup. The output beam of the CTL was frequency modulated with

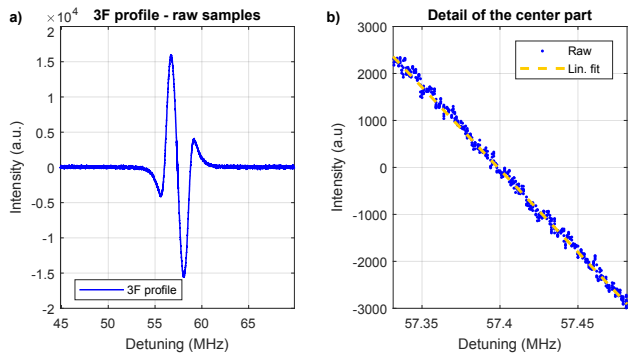

**Fig. 3.** (a) Third-harmonic profile of the R7 line of the  $2\nu_3$  band obtained using 40-cm-long cell filled to a pressure of 1, 6 Pa and (b) the detail of the center part with an indicated linear fit.

an acousto-optical modulator/shifter (AOM) (5-kHz modulation frequency, 3-MHz FM deviation) and amplified in an Er-doped fiber amplifier (EDFA) with  $\approx 200$ -mW output power. A voltage-controlled optical attenuator (VOA; V1550PA, Thorlabs) suppressed residual amplitude fluctuations. The laser light was fed through an optical fiber collimator and Faraday isolator into the free-space part of the optical setup, where it split on polarizing beam splitters into two counter-propagating beams: pump ( $\approx 120$  mW) and probe ( $\approx 10$  mW) with diameters of 2.3 mm. The probe signal from a 40-cm-long refillable absorption cell was synchronously demodulated using a digital lock-in amplifier (SRS 865, Stanford Research Systems) with third harmonic detection. We would like to note that we identified the analog modulation signal as susceptible to residual offsets from zero and zero-drifts, which could cause significant shifts in the observed line centers' frequencies.

**Measurement of the line centers' frequencies.** Before actual measurement, the vacuum system was evacuated and then filled with HCN to the desired pressure. The laser frequency was detuned from the line profile, and the offset of the lock-in amplifier was zeroed (to suppress the residual amplitude modulation).

After preparation, the scanning sequence was commenced in the frequency range of  $\pm 12.5$  MHz around the line center. We used 1-kHz steps around the central part of the profile and 5-kHz steps in the rest of the range at the rate of 100 ms/step. The intensity signal was digitized and recorded with auxiliary information (e.g., cell pressure).

From the recorded data (typical SNR  $\approx 100$  dB), shown in Fig. 3, we averaged the readings at individual points and (coarsely) removed any residual background caused by residual amplitude modulation and etalon effects in the optical part. We identified the third-harmonic profile's minimum and maximum, and interpolated the points around the central part to detect the zero-crossing, which corresponds to the line's center frequency.

To investigate the measurement repeatability, we ran repeated scans of the R7 line profile (arbitrarily selected) over slightly longer than a day. Then we selected and measured the profiles of 17 lines (those with convenient offset from the nearest OFC tooth), ten times each. We carried out the measurements with pressures between 1.45 Pa and 1.8 Pa.

**Results and observations.** The R7 line frequency recording, shown in Fig. 4(b), reveals the standard deviation of frequency determination of 0.5 kHz.

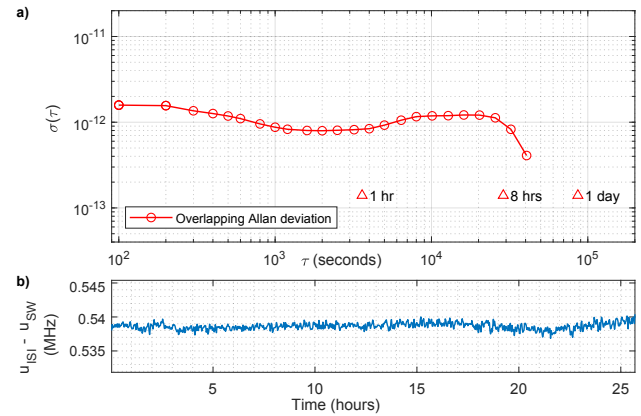

**Fig. 4.** (a) Overlapping Allan deviations calculated from repeated scanning over the R7 absorption line and (b) the frequency recording expressed as a coincidence of measurements with saturated spectroscopy ( $\nu_{ISI}$ ) and published data ( $\nu_{SW}$ ) [2].

**Table 1. Center Frequencies of the  $2\nu_3$  Band of  $\text{H}^{13}\text{C}^{14}\text{N}$ , Measured in a 40-cm Cell Filled to the Pressure of  $(1.65 \pm 0.10)$  Pa and Interpolated to Zero Pressure<sup>a</sup>**

Line	This work <sup>b</sup>	Ref. [2] <sup>c,d</sup>	$\delta\nu$ (MHz)
	$\nu_{ISI}$ (Hz)	$\nu_{SW}$ (MHz)	
R23	196080395.145 (25)	196080394.150(1154)	0.995
R18	195779623.109 (25)	195779622.061(1023)	1.048
R12	195379001.274 (25)	195379000.555(1019)	0.719
R11	195308040.399 (25)	195308039.664(1018)	0.734
R9	195162540.395 (25)	195162539.755(1016)	0.640
R8	195088004.481 (25)	195088003.897(1016)	0.584
R7	195012280.156 (25)	195012279.620(1015)	0.536
R5	194857273.056 (25)	194857272.495(1013)	0.561
R3	194697533.032 (40)	194697532.583(1012)	0.450
R2	194615892.657 (40)	194615892.235(1011)	0.422
P4	194011541.171 (25)	194011540.774(1004)	0.397
P5	193920533.536 (25)	193920533.046(1003)	0.491
P7	193735035.335 (25)	193735034.897(1002)	0.439
P10	193448113.529 (25)	193448113.185(999)	0.344
P16	192843268.251 (25)	192843267.988(992)	0.263
P20	192417282.929 (25)	192417282.740(988)	0.189
P24	191973284.118 (25)	191973284.280(1106)	-0.162

<sup>a</sup>Measured pressure coefficient from [2], Table 1 are considered.

<sup>b</sup>A general estimate of the uncertainty is stated.

<sup>c</sup>Calculated values from [2], table 4 are considered.

<sup>d</sup>The counter-intuitive slightly decreasing trend in uncertainties results from the fact the reference data are expressed as wavelength and with the precision of  $\approx 0.12$  MHz.

The overlapping Allan deviations, in Fig. 4(a), reach the bottom of  $8 \times 10^{-13}$  for  $\tau \approx 1800$  s and the entire curve fits below  $1.6 \times 10^{-12}$ , which translates to 0.3 kHz. The frequency recording is compensated for the pressure shifts and also for slight drifts (0.05 Pa/hr) in the pressure measurement we observed during the measurement. Further investigation is needed here.

The line centers measured so far and extrapolated to zero pressure using the previously published pressure coefficients [2], displayed in Table 1, reveals approximately forty-fold improvement in the uncertainty of the center frequency determination compared to [2]. For the present data, the 25-kHz (40-kHz) uncertainty was stated uniformly. This qualified estimate took



into account uncertainty in pressure coefficients and pressure measurement ( $\approx 10$  kHz), the observed spread of values with repeated measurement of individual lines ( $\approx 5$  kHz), the uncertainty of the fitting function ( $\approx 3$  kHz), residual zero-offset or profile background ( $\approx 3$  kHz), residual offsets and drifts in the harmonic detection analog control ( $\approx 3$  kHz), and additional (large) safety margin for potential systematic effects in, e.g., the degree of purity of HCN gas, in-homogeneous density of the HCN gas in the cell, and other phenomena unknown in this period of the research. The uncertainty was increased for lines R2, R3 (40 kHz) due to observed distortion in the profile, which we attribute to residual spectroscopic features in close vicinity of the measured line. Further investigation is required before the complete atlas will be issued. For the comparison with the previously published measurement, we used the calculated frequencies, their uncertainties, and pressure shifts from [2].

The results indicate a linear trend in the frequency deviations depending on the absorption line frequency, as shown in Fig. 1. It reveals that the present data systematically deviate from previous data toward higher frequencies. The deviation lies within the stated uncertainty for the previous data (except for the R18); nonetheless, in applications using, for instance, the frequency resolution against multiple lines, this deviation might skew the measurement results significantly. We may attribute this systematic deviation to the fact that the wavelength meter used for the measurement in [2] was referenced right at the  $\lambda = 1560$  nm, where both datasets better coincide. The observed systematic deviation also might explain the HCN cell calibration issues discussed in [5].

**Conclusion.** We developed the widely tunable scanning laser system with sub-kHz linewidth and the absolute accuracy of  $10^{-13}$ . In conjunction with the optical assembly for saturated spectroscopy and a vacuum system allowing for precise pressure control in the gas cell, the third-harmonic profiles of selected lines in the  $\text{H}^{13}\text{C}^{14}\text{N } 2\nu_3$  band were measured.

We measured  $\approx 30\%$  of the lines in the spectrum of interest with an associated uncertainty down to 25 kHz ( $< 1.3 \times 10^{-10}$  fractional uncertainty). The precision achieved represents an approximately forty-fold improvement against previous investigations [2]. To the best of our knowledge, a systematic investigation of such an amount of individual lines by saturated spectroscopy has not been reported before. Compared to the previously published data, we generally confirmed the validity and correctness of the previous results. However, we identified a systematic deviation of the line centers' determination below the resolution of the original data.

We demonstrated a methodology allowing for further measurement of the complete spectra of interest, detailed investigation of the pressure effects, and stated the associated uncertainties. Such an outcome would hopefully be a valuable addition to the current state-of-the-art in the well-known and accepted spectroscopic references for the realization of the SI meter in the 1550-nm region. The refined spectroscopic data might help the hydrogen cyanide toward inclusion in the CIPM's *Recommended values of standard frequencies* [16] and *Mise en pratique for the definition of the SI meter* [17].

**Funding.** European Metrology Programme for Innovation and Research (17IND03 LaVA); Ministerstvo Školství, Mládeže a Tělovýchovy (CZ.02.1.01/0.0/0.0/16\_026/0008460, CZ.1.05/2.1.00/01.0017, LO1212); Akademie Věd České Republiky (RVO:68081731).

**Acknowledgments.** Authors acknowledge the support from and fruitful discussion with the team from NPL, UK involved in the LaVA project (A. Lewis, B. Hughes, M. Campbell). Authors acknowledge the support with HCN-related calculations from our dear colleague Prof. Frédéric Du Burck from Laboratoire de Physique des Lasers, Université Sorbonne Paris Nord. The project 17IND03 LaVA has received funding from the EMPIR programme co-financed by the Participating States and from the European Union's Horizon 2020 research and innovation. The research used infrastructure supported by MEYS CR, EC, and CAS (LO1212, CZ.1.05/2.1.00/01.0017, RVO:68081731).

**Disclosures.** The authors declare no conflicts of interest.

**Data availability.** Data underlying the results presented in this paper are not publicly available at the time of publication but may be obtained from the authors upon reasonable request.

## REFERENCES

1. H. Sasada and K. Yamada, *Appl. Opt.* **29**, 3535 (1990).
2. W. C. Swann and S. L. Gilbert, *J. Opt. Soc. Am. B* **22**, 1749 (2005).
3. C. Edwards, H. Margolis, G. Barwood, S. Lea, P. Gill, and W. Rowley, *Appl. Phys. B* **80**, 977 (2005).
4. S. R. Sternberg, *Computer* **16**, 22 (1983).
5. J. Dale, B. Hughes, A. J. Lancaster, A. J. Lewis, A. J. H. Reichold, and M. S. Warden, *Opt. Express* **22**, 24869 (2014).
6. B. Hughes, M. A. Campbell, A. J. Lewis, G. M. Lazzarini, and N. Kay, *Videometrics, Range Imaging, and Applications XIV* **10332**, 1033202 (2017).
7. R. Li, K. Gibble, and K. Szymaniec, *Metrologia* **48**, 283 (2011).
8. A. D. Ludlow, M. M. Boyd, J. Ye, E. Peik, and P. O. Schmidt, *Rev. Mod. Phys.* **87**, 637 (2015).
9. T. Fortier and E. Baumann, *Commun. Phys.* **2**, 153 (2019).
10. M. D. Labachellerie, K. Nakagawa, Y. Awaji, and M. Ohtsu, *Opt. Lett.* **20**, 572 (1995).
11. Y. Awaji, K. Nakagawa, M. de Labachellerie, M. Ohtsu, and H. Sasada, *Opt. Lett.* **20**, 2024 (1995).
12. J. Henningsen, J. Hald, and J. C. Peterson, *Opt. Express* **13**, 10475 (2005).
13. M. Čížek, L. Pravdová, T. Minh Pham, A. Lešundák, J. Hrabina, J. Lazar, T. Pronebner, E. Aeikens, J. Premper, O. Havliš, R. Velc, V. Smotlacha, L. Altmannová, T. Schumm, J. Vojtěch, A. Niessner, and O. Číp, *Opt. Express* **30**, 5450 (2022).
14. P. Pánek and A. Kuna, in *Proceedings of the 44th Annual Precise Time and Time Interval Systems and Applications Meeting*, (2012), pp. 301–310.
15. O. Číp, A. Lešundák, T. M. Pham, V. Hucl, M. Čížek, J. Hrabina, Š. Řeřucha, J. Lazar, P. Obšil, R. Filip, and L. Slodička, in *2018 European Frequency and Time Forum, EFTF 2018* pp. 392–394 (2018).
16. F. Riehle, P. Gill, F. Arias, and L. Robertsson, *Metrologia* **55**, 188 (2018).
17. R. Schödel, A. Yacoot, and A. Lewis, *Metrologia* **58**, 052002 (2021).