



ISTITUTO NAZIONALE DI RICERCA METROLOGICA Repository Istituzionale

An experimental setup for the metrological characterization of MEMS microphones

Original

An experimental setup for the metrological characterization of MEMS microphones / Saba, F.; Durando, G.; Paesante, D.; Corallo, M.; Schiavi, A.; Prato, A.. - (2022). (Intervento presentato al convegno 24th International Congress on Acoustics ICA 2022 tenutosi a Gyeongju, Corea del Sud nel 24-28 Ottobre 2022).

Availability:

This version is available at: 11696/76140.3 since: 2023-06-30T14:40:14Z

Publisher:

Published

DOI:

Terms of use:

This article is made available under terms and conditions as specified in the corresponding bibliographic description in the repository

Publisher copyright

(Article begins on next page)

ABS-0638

An experimental setup for the metrological characterization of MEMS microphones

Fabio SABA¹; Giovanni DURANDO; Davide PAESANTE; Mario CORALLO; Alessandro SCHIAVI;
Andrea PRATO

¹INRIM, Istituto Nazionale di Ricerca Metrologica, Turin, Italy

ABSTRACT

The increasingly widespread use of MEMS microphones, particularly for wireless sensor networks and microphone arrays applications such as sound source localization and acoustic noise analysis, calls for a metrological characterization of this kind of sensors, in order to ensure the traceability and reliability of their acoustic measurements. In this paper, we describe an experimental setup for the pressure calibration of MEMS microphones by the comparison method, which allows determining the pressure sensitivity levels of analog MEMS microphones mounted on 12.5 mm diameter PCB evaluation boards, in the frequency range from 125 Hz to 12.5 kHz. The first results of the calibration of an analog MEMS microphone are presented and discussed, and the evaluation of the uncertainty associated with the measurements of pressure sensitivity levels is reported.

Keywords: MEMS microphones, calibration, comparison method

1. INTRODUCTION

MEMS microphones are increasingly exploited in many acoustic applications basically due to their small size, low power consumption, and reduced production cost. Besides their integration in portable devices, like smartphones, laptops, tablets, etc., MEMS microphones show a great potential for the realization of low-cost wireless sensor networks for environmental noise monitoring and mapping, acoustic noise analysis, and sound source localization.

In order to ensure the reliability and the accuracy of their acoustic measurements, metrological traceability is needed, meaning that proper calibration methods should be identified according with the specific uncertainty requirements. This evaluation has to be done with a particular care to different sources of error that the particular type of technology exploited for MEMS microphones could introduce in a traditional acoustic calibration system. Furthermore, these sensors have different constraints comparing to condenser microphones, that requires ad hoc configurations and new procedures to characterize them properly.

2. PRESSURE CALIBRATION OF MEMS MICROPHONES

The determination of the sensitivity of MEMS microphones in pressure field conditions is usually of more practical interest compared to their free field response, due to the small package size (in the order of the millimeter), and the frequency range of operation, typically from 100 Hz to 10 kHz. In fact, the small differences between pressure and free field responses that are expected for MEMS microphones in their nominal frequency range, and the target uncertainties of typical applications, do not justify their calibration in free field conditions, which is much more time-consuming than pressure calibration and requires the use of anechoic or hemi-anechoic chambers (1). Nevertheless, MEMS microphones are mounted on different devices in a variety of configurations, which typically consist of acoustic cavities and sound wave guides, realized by different components, like plastic covers, gaskets, and PCB supports, so that their frequency response may be significantly affected (2). Thus, manufacturers usually provide MEMS microphones mounted on PCB evaluation boards to allow and facilitate performance testing in ordinary installation conditions.

¹ f.saba@inrim.it

In this Section, we describe the experimental setup and the measurement procedure for the pressure calibration of analog MEMS microphones mounted on 12.5 mm diameter PCB boards, by the comparison method in the frequency range from 125 Hz to 12.5 kHz. The evaluation of the sound field corrections for calibration between microphones of different sizes is discussed.

2.1 Experimental setup and measurement procedure

The pressure calibration of MEMS microphones mounted on 12.5 mm diameter PCB boards has been performed by comparison against a reference LS2aP condenser microphone, using the Brüel & Kjær WA0817 active coupler (Figure 1), which provides the simultaneous acoustic excitation of the two microphones under comparison.



Figure 1 – Brüel & Kjær WA0817 active coupler

The MEMS microphone considered in this work is a STMicroelectronics differential analog bottom-port MEMS microphone, model ST MP23AB01DH, mounted on a 12.5 mm diameter STMicroelectronics PCB board support, model STEVAL-MKI139V5. The PCB board is 1 mm in thickness and has a central hole of about 0.4 mm diameter on the front-side, for exposing the bottom-port MEMS microphone fixed on the back-side of the PCB to the sound field. To allow inserting this type of MEMS microphone into the active coupler, face-to-face with the reference microphone with parallel front surfaces separated by less than a tenth of the wavelength at the highest frequency of interest, the special mount shown in Figure 2 has been realized.

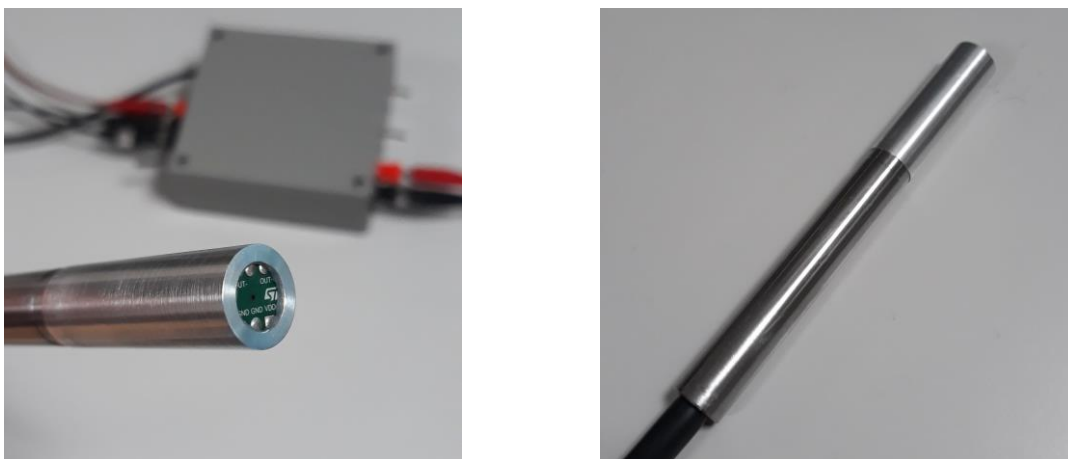

Figure 2 – Mount for MEMS microphones on 12.5 mm diameter PCB boards

It consists of a 115 mm hollow steel rod (12.5 mm external diameter) terminated on one side with two fins for fitting the 12.5 mm diameter PCB board and housing the cables. The steel rod with the PCB fitted and connected to cables is plugged by an aluminium cap (13.3 mm external diameter) with a front hole of 8.5 mm diameter and 0.5 mm thickness. A rubber ring gasket of 1 mm thickness and

8.5 mm internal diameter is interposed between the PCB front surface and the cap to ensure proper sealing and prevent air leakages. The cap is fitted with interference to the steel rod, and a cable grommet is used for sealing the cable outlet section. The particular design of the mount facilitates the assembly and replacement of the 12.5 mm diameter PCB board, and does not modify the frequency response of the MEMS microphone. Its relevant parts and the assembly scheme are shown in Figure 3.

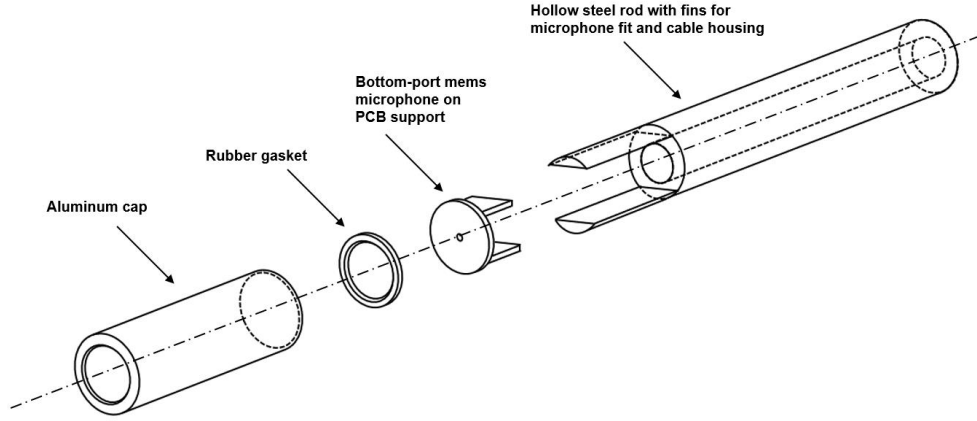

Figure 3 – Assembly scheme of the MEMS microphone mount

A custom-made preamplifier has been realized to provide a stable DC power supply to the MEMS microphone, and to amplify and filter its output signal. The metrological characterization of the preamplifier has been carried out by measuring its amplification gains (0 dB, 20 dB, and 40 dB) by an SI-traceable digital multimeter in the frequency range of interest, at different amplitudes of the AC voltage input provided by a signal generator. Self-generated electrical noise has been measured by short-circuiting the preamplifier input by an equivalent MEMS microphone load, and settled around 27.3 dB. The expanded uncertainty associated with amplification gains has been evaluated considering repeatability and linearity contributions, and resulted lower than 0.05 dB.

The measurement chain of the reference microphone consists of a Brüel & Kjær LS2aP condenser microphone, model 4180, and a Brüel & Kjær 2669 preamplifier, connected to the Brüel & Kjær 2690A Nexus microphone conditioner. The pressure sensitivity of the LS2aP reference microphone is determined by the primary reciprocity method, whereas the gains of preamplifier and microphone conditioner are determined by measuring the amplitudes of the AC voltage input provided by a signal generator and the corresponding AC voltage output, by an SI-traceable digital multimeter in the frequency range of interest.

The output signals from the measurement chain of the reference microphone, and from the measurement chain of the MEMS microphone (output of the custom-made preamplifier) are acquired and measured by a National Instrument 2-channels 16-bit DAQ system, model NI PCI 4451, used as FFT analyzer and calibrated against an SI-traceable digital multimeter.

Assuming a uniform pressure field inside the active coupler during comparison calibration, the ratio between the sensitivities of reference and MEMS microphones is proportional to the geometric mean of the ratios between the output voltages of the two microphone measurement chains, which are obtained by switching their channel connections on the DAQ system. In this way, the contribution of the different gains of the two channels of the DAQ system is cancelled out. Furthermore, by rotating the reference microphone around its axis and repeating the comparison calibration, it is possible to evaluate the uncertainty contributions due to the effect of possible non-uniform sound fields in the active coupler on the reference microphone diaphragm. Assuming a uniform pressure field inside the active coupler, the measurement model for the determination of the pressure sensitivity level of the MEMS microphone at reference ambient conditions (101.325 kPa, 23 °C, 50 %RH), S_M , expressed in dB (relative to 1 V Pa⁻¹), can be written as:

$$S_M = S_{LS2} - [r_{1-2} + r_{2-1} + \alpha]/2 + G_{2669} + G_{Nexus} - G_M \quad (1)$$

where S_{LS2} is the pressure sensitivity level of the reference LS2aP microphone at reference ambient conditions, expressed in dB (relative to 1 V Pa⁻¹), r_{1-2} and r_{2-1} are 20-times the logarithmic voltage ratios measured by the 2-channels DAQ system used as FFT analyzer, obtained by switching the

channel connection of microphones measurement chains, α is the correction in dB accounting for the differences between pressure, temperature, and humidity coefficients of microphones, whereas G_{2669} , G_{Nexus} , and G_M are the dB gains of the Brüel & Kjær 2669 preamplifier, the Brüel & Kjær 2690A Nexus microphone conditioner, and the custom-made MEMS preamplifier, respectively.

Because of the different sizes of reference and MEMS microphones diaphragms, special care must be addressed to the evaluation of sound field corrections due to non-uniform acoustic pressure distribution in the active coupler. This point is detailed in the following Section.

2.2 Sound field correction

In pressure calibration by comparison between microphones of different diameters, sound field corrections due to non-uniform sound fields play an important role, especially at frequency higher than 4 kHz. Depending on microphones configuration and the extent of non-uniformity, the difference between the mean acoustic pressures actually sensed by microphones can be such that sensitivity corrections of more than 1 dB are required. For instance, for the pressure calibration of a WS3 microphone (4.13 mm diaphragm diameter) against a reference LS2 microphone (9.3 mm diaphragm diameter) by the comparison method, sensitivity corrections from about -0.2 dB to -1.4 dB are expected in the frequency range from 8 kHz to 20 kHz (3, 4). The reason for such corrections is that in case of non-uniformity, the more different the diameters of microphones' diaphragms, the higher the difference between the mean acoustic pressures actually sensed by the microphones, which correspond to the mean acoustic pressures integrated over the microphones' diaphragms according to the radial distribution of their sensitivities.

Concerning the comparison calibration of the MEMS microphone by the experimental setup described in Section 2.1, the effect of non-uniform sound fields is expected to be significant and should be carefully analyzed. To this aim, since an experimental approach is unpractical and difficult to be effectively carried out, we used the Finite Element Method (FEM) to solve numerically the Helmholtz equation, obtaining the expected acoustic pressure distribution that occurs between microphones' diaphragms within the Brüel & Kjær WA0817 active coupler, during comparison calibrations. Preliminarily, the numerical model, implemented and solved by the FreeFem++ software (5), has been validated against the results published by Barham et al (3), for the comparison calibration of WS3 against LS2 reference microphones, for which the corrections for acoustic pressure distribution between microphones' diaphragms were calculated analytically. Deviations lower than 0.03 dB with respect to the analytical corrections have been obtained. Once the computational domain and boundary conditions are properly defined, the FEM modelling of the acoustic field in the active coupler allows evaluating the mean acoustic pressures \tilde{p}_{LS2} and \tilde{p}_M acting on the LS2aP and MEMS microphones' diaphragms, respectively, from which the sound field correction δ that should be added to the measured sensitivity level given by equation (1), can be calculated as:

$$\delta = 20 \log_{10}(\tilde{p}_{LS2}/\tilde{p}_M) \quad (2)$$

where the mean acoustic pressure \tilde{p}_{LS2} is weight-averaged over the LS2aP microphone diaphragm, according to the typical radial distribution of pressure sensitivity, as given by (3), whereas \tilde{p}_M is uniformly averaged over the MEMS microphone diaphragm.

The values of the numerical estimates of sound field corrections mainly depend on the assumptions made for the definition of the computational domain, sound source, and boundary conditions. In particular, the acoustic field in the active coupler has been simulated assuming a 2D cylindrical axisymmetric domain, i.e. a radially symmetric sound source realized by the active coupler, and a coaxial alignment between the central hole of the PCB board of the MEMS microphone, the coupler cavity and the reference microphone. Concerning boundary conditions, the LS2aP reference microphone diaphragm has been described as a finite impedance boundary, where the acoustic impedance has been calculated from the values of characteristic parameters of Brüel & Kjær 4180 condenser microphones, whereas for the MEMS microphone, the diaphragm has been assumed as an infinite acoustic impedance (sound hard boundary). Furthermore, the acoustic cavity of the bottom-port MEMS microphone has been simulated considering the geometrical configuration described in (2), and the distance between the MEMS diaphragm and the PCB front surface has been measured by an optical microscope. The computational domain, and an example of the acoustic pressure distribution obtained by the FEM model are shown in Figure 4.

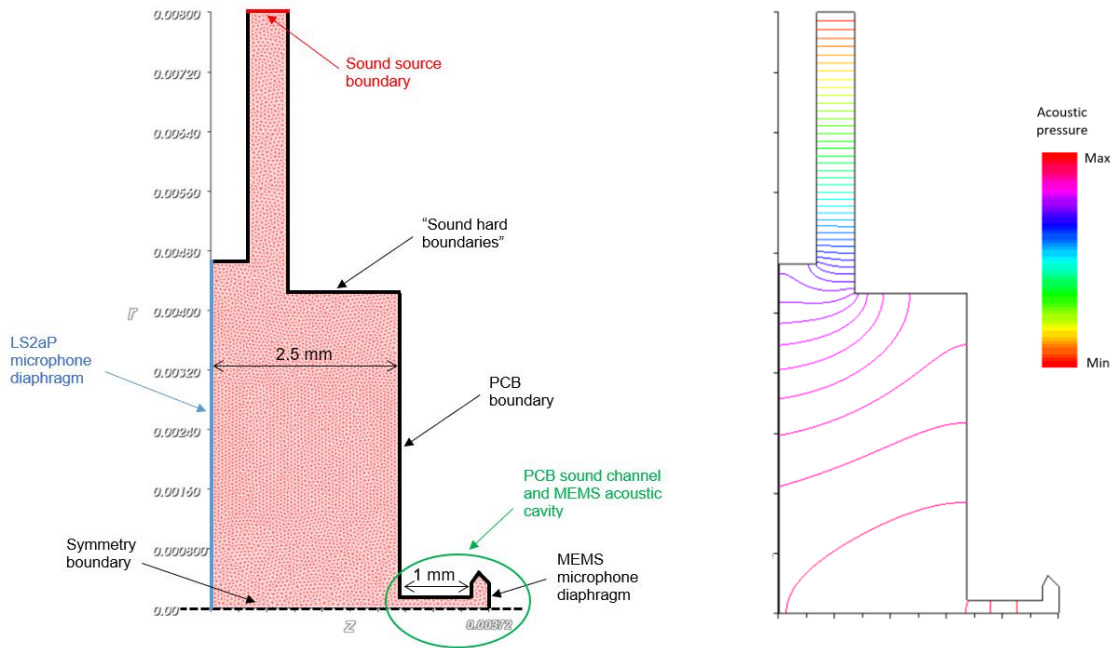

Figure 4 – FEM modelling of acoustic pressure distribution in the active coupler

It is important to observe that the assumptions of axisymmetric domain and circularly symmetric sound source made for the FEM model do not usually fit the real case, where asymmetric sound fields can take place. To evaluate experimentally such asymmetry contributions, the MEMS microphone can be calibrated by comparison against both an LS2 and a WS3 reference microphone, the latter being calibrated in turn against the LS2 microphone. The ratio between the MEMS microphone sensitivities obtained by the two reference microphones is a function of the sound field corrections only, and can be compared against the numerical model. Differences between numerical and experimental results can be associated with asymmetry contributions. In Table 1, the estimates of sound field corrections δ are reported for the frequency range from 125 Hz to 12.5 kHz.

Table 1 – Sound field corrections

Frequency, Hz	δ , dB
125	0.00
250	0.00
500	0.00
1000	0.02
2000	0.03
4000	-0.03
8000	-0.18
10000	-0.32
12500	-0.56

The uncertainty associated with sound field corrections can be evaluated by the numerical model itself, changing the model's inputs based on their typical uncertainties and variability, and evaluating the corresponding variation of corrections. Such an uncertainty evaluation is out of the scope of the present work; here, we prudently consider an expanded uncertainty (95% coverage probability) equal to the correction value, assuming a uniform probability distribution. This uncertainty takes also into account the contribution due to the different acoustic impedances of microphones' diaphragms, as they affect the acoustic pressure distribution in the coupler.

3. RESULTS

The frequency response of the MEMS microphone has been evaluated in pressure field conditions using the experimental setup and the measurement procedure described in Section 2.1, and applying the sound field corrections discussed in Section 2.2. The pressure sensitivity level of the MEMS microphone has been measured in the range from 125 Hz to 12.5 kHz, performing several repetitions of comparison calibration at different ambient conditions, i.e. air temperature within 25 ± 2 °C, static pressure within 99 ± 2 kPa, and relative humidity within 45 ± 15 %, and at different rotation angles of the reference LS2aP microphone around its axis. The frequency response of the MEMS microphone is shown in Figure 5, where the mean values of pressure sensitivity levels are normalized to the one obtained at 1 kHz. The response is almost flat up to 4 kHz, where the normalized sensitivity level is within ± 0.4 dB, whereas for frequencies above 4 kHz, the sensitivity increases due to the Helmholtz resonance in the acoustic cavity of the MEMS microphone.

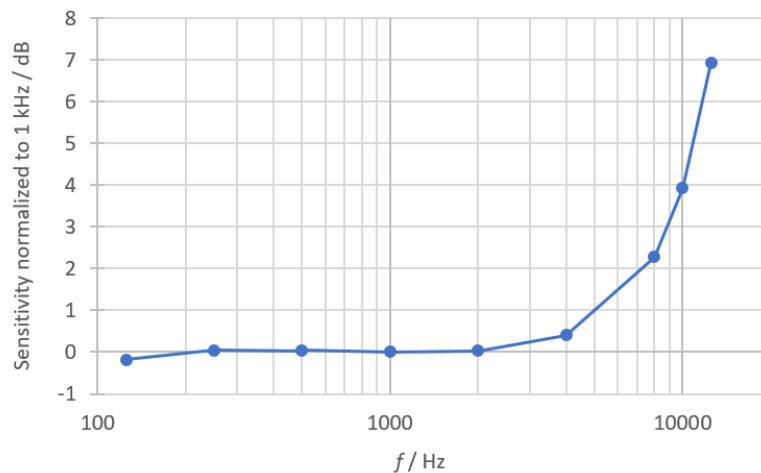

Figure 5 – Measured frequency response of the MEMS microphone, from 125 Hz to 12.5 kHz, normalized to the pressure sensitivity level at 1 kHz

In Figure 6, the batch of measured sensitivity levels of the MEMS microphone is plotted as deviations from the mean value of the sensitivity level, at each frequency in the range of interest. Measured sensitivity levels settle within ± 0.08 dB.

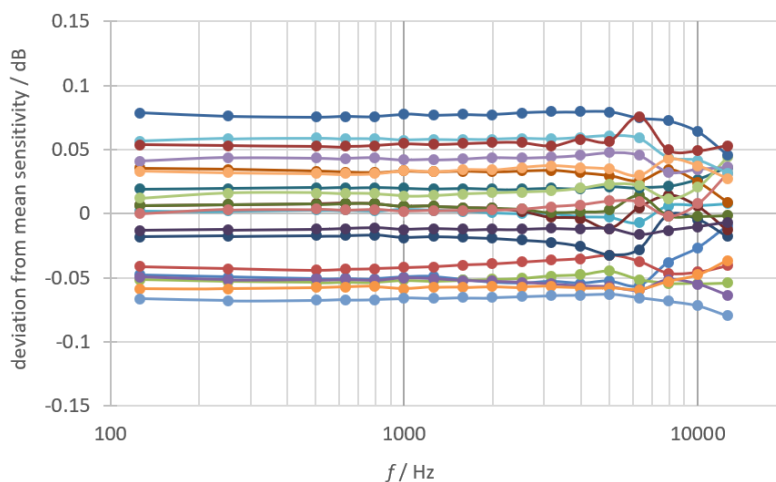

Figure 6 – Batch of measurement data, plotted as deviations in dB from the mean value of the sensitivity level of the MEMS microphone

The uncertainty associated with the measured sensitivity levels has been evaluated for each

frequency in the range of interest. The main uncertainty contributions are related to i) the microphones measurement chains, which also comprehend the uncertainties associated to preamplifiers' gains, ii) the repeatability of measurements, iii) the above-mentioned uncertainty of sound field corrections, and iv) the uncertainty associated with the DAQ system. In Table 2, the overall expanded uncertainty (95% coverage probability) of the measured pressure sensitivity level of the MEMS microphone, is reported for the frequency range of interest.

Table 2 – Uncertainty of the MEMS microphone sensitivity level

Frequency, Hz	Expanded uncertainty
	U , dB
≤ 4000	0.15
8000	0.25
10000	0.40
12500	0.67

The increase of the uncertainty values at frequencies higher than 4 kHz, is mainly due to the contribution related to the sound field corrections.

4. CONCLUSIONS

The procedure presented in this work can be a good starting point for the definition of a standard method for MEMS microphone evaluation and characterization, thanks to an efficient and simple experimental setup that improves repeatability of measurements and a particular focus on physical phenomena that can be significant in the results evaluation. Nevertheless, this method can be refined to get a better uncertainty for the microphone sensitivity level, analyzing more carefully the effect of non-uniform acoustic pressure distribution between microphones of different sizes to get accurate corrections. To accomplish this, it is fundamental to continue comprehensive physical analysis together with new experimental tests in different calibration setups and measurement systems. However, the MEMS microphones tested for the purpose of this work showed very promising behaviour and characteristics, e.g. in stability and repeatability, that can be potentially extended to a wider frequency range with a proper evaluation of sound field corrections. This provides new appeal to the MEMS microphones, that are confirming the promising expectations that put them under the spotlight of acoustic metrological research.

REFERENCES

1. Prato A, Montali N, Guglielmone C, Schiavi A. Pressure calibration of a digital microelectromechanical system microphone by comparison, *J Acoust Soc Am.* 2018;144(4):EL297-EL303.
2. STMicroelectronics (2016). "AN4427 Application note. Gasket design for optimal acoustic performance in MEMS microphones".
3. Barham R, Barrera-Figueroa S, Avison JEM. Secondary pressure calibration of measurement microphones, *Metrologia* 2014;51:129-138.
4. IEC 61094-5 (2016). *Measurement Microphones - Part 5: Methods for Pressure Calibration of Working Standard Microphones by Comparison* (IEC, Switzerland).
5. Hecht F. New development in FreeFem++. *J Numer Math.* 2012;20(3-4):251-265.