



ISTITUTO NAZIONALE DI RICERCA METROLOGICA Repository Istituzionale

attoSENSORICS IDS3010 Industrial Displacement Sensor Evaluation for Integration in a Measuring System

Original

attoSENSORICS IDS3010 Industrial Displacement Sensor Evaluation for Integration in a Measuring System / Francese, Claudio. - (2017).

Availability:

This version is available at: 11696/75182 since: 2023-01-12T14:37:15Z

Publisher:

Published

DOI:

Terms of use:

This article is made available under terms and conditions as specified in the corresponding bibliographic description in the repository

Publisher copyright

(Article begins on next page)

Claudio Francese

attoSENSORICS IDS3010

Industrial Displacement Sensor

Evaluation for Integration in a Measuring System

T.R. 11/2017

08/05/2017

Contents

Table of Figures	2
Abstract	3
IDS3010 highlights	3
Selection of the Sensor Head	4
Simulation of Optical Setup	4
Sensor Head D4/F13	6
Instrument Interfacing.....	7
Ethernet connection	7
Access through the integrated webserver	7
Access through the .NET API	8
Access through JSON-RPC.....	8
Realtime Interface Connector	8
Integration of the IDS3010 in a Measurement Setup	10
Conclusions.....	11
Appendix.....	12

Table of Figures

Figure 1 - IDS3010.....	3
Figure 2 - IDS3010 Connectors	3
Figure 3 - Sensor Head.....	4
Figure 4 - Reflected Power	4
Figure 5 - Beams Reflection on the Silicon Sphere	4
Figure 6 - Simulation of Sensor Head - raytracing	5
Figure 7 - Simulation of the Returned Power.....	6
Figure 8 - Integrated WebServer	7
Figure 9 - Realtime Outputs Connector.....	8
Figure 10 - Realtime Outputs Connector Pinout	10
Figure 11 - Acquisition System Architecture	10

Abstract

This report describes some solutions for the integration in a measurement system of an attoSENSORICS IDS3010 and its interfacing capabilities according to the available specifications and operating manuals.

This preliminary study is intended to evaluate whether the instrument can be used as a validation tool for the verification of FEM simulation results for deformations in a silicon sphere loaded with a test mass. Automation is needed to increase the speed and the repeatability of the measures and the number of acquired samples.

IDS3010 highlights

The IDS3010 is a three-axes absolute interferometer with a declared 1 pm resolution up to 5 meters distance. The full documentation is available on the manufacturer website [1].



FIGURE 1 - IDS3010

The instrument is equipped with an Ethernet connection, a Realtime Interface connector, an Environmental Compensation Unit (ECU) and a General Purpose I/O (GPIO) connector.

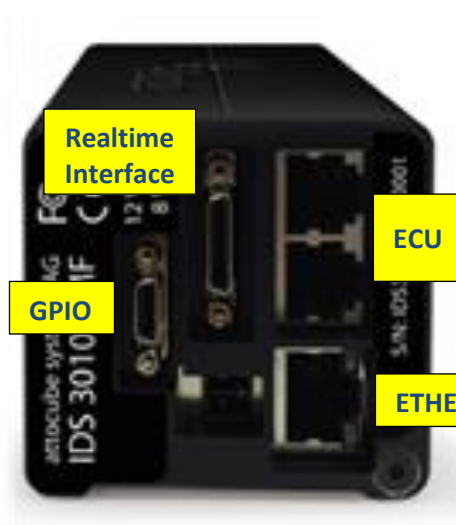

FIGURE 2 - IDS3010 CONNECTORS

In later sections the Ethernet and Realtime Interface connectors will be discussed.

Selection of the Sensor Head

The instrument must be connected to a Sensor Head which has to be properly chosen according to the measurement conditions (distance, reflection coefficient of the target, environmental conditions).

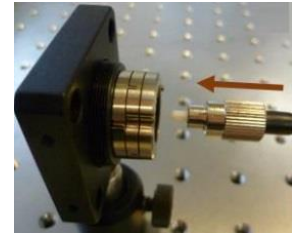

FIGURE 3 - SENSOR HEAD

The operating principle of the instrument implies that only 4% of the emitted laser radiation is sent back to the reference arm of the interferometer so the reflected power from the measuring arm must be 4% of the emitted power as well in order to properly operate the device.

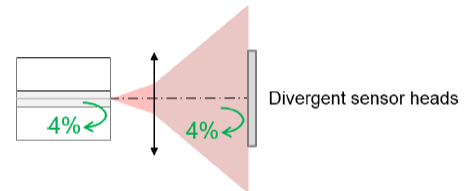

FIGURE 4 - REFLECTED POWER

The requested power level can be achieved by selecting the Sensor Head according to the reflection coefficient of the target and the operating conditions. The manufacturer supplies two standard types of heads, collimating and focussing with different focal lengths. Also custom sensors can be supplied upon request.

Simulation of Optical Setup

When the sensor is used to measure the distance of a metallic sphere, the target acts as a diverging mirror as shown in Figure 5. Although the optics can be manually set up to give the expected return power, a first order analysis is performed to evaluate the behaviour and returned power for a given standard sensor.

Given a sensor with diameter D , focal length F and a sphere with radius R , center $C(c,0)$, for a given emitted beam from the point $A(0, h)$ of the sensor, the sphere will reflect it to the point $B(0,b)$ belonging to the plane containing the sensor.

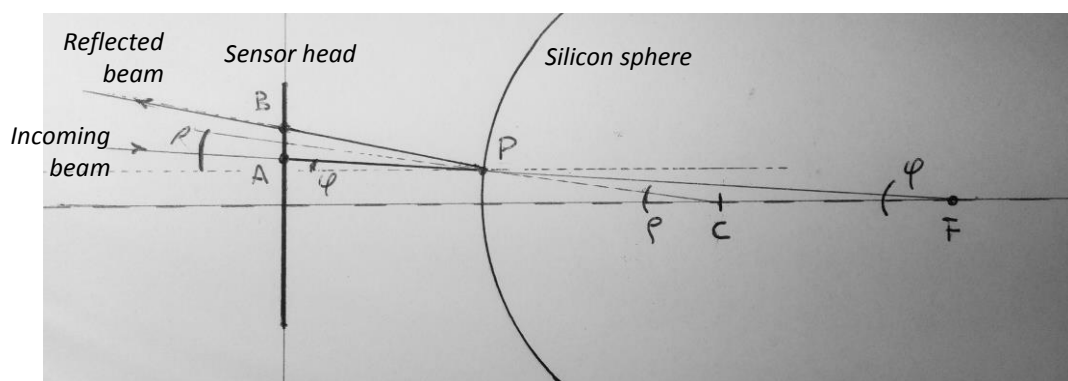

FIGURE 5 - BEAMS REFLECTION ON THE SILICON SPHERE

The condition $P_{reflected} \cong 0.04 P_{incoming}$ at first order of approximation can be obtained by imposing that 4 percent of the total power is associated only to all the beams which will be reflected back into the sensor head.

The coordinate of the point B is (0, b) where

$$b = R \sin \rho + (C - R \cos \rho) \tan \gamma$$

and

$$\varphi = \tan^{-1} \frac{a}{F}$$

$$\rho = \sin^{-1} \left(\frac{a}{R} \cos \varphi - \frac{C}{R} \sin \varphi \right) + \varphi$$

$$\gamma = 2\rho - \varphi$$

Only the reflected beams with $b < D/2$ will enter into the sensor so, when a value a_{limit} is found for which $b_{limit} = D/2$, the total relative reflected power will be $\frac{P_{reflected}}{P_{incident}} = \frac{\pi a_{limit}^2}{\pi D^2/4} = 4 \left(\frac{a_{limit}}{D} \right)^2$ in the approximation of a uniform beam power distribution in the range $-a_{limit} < a < +a_{limit}$ and unitary reflectivity of the sphere.

Given the parameters of a real setup, the relationship can be easily evaluated and plotted.

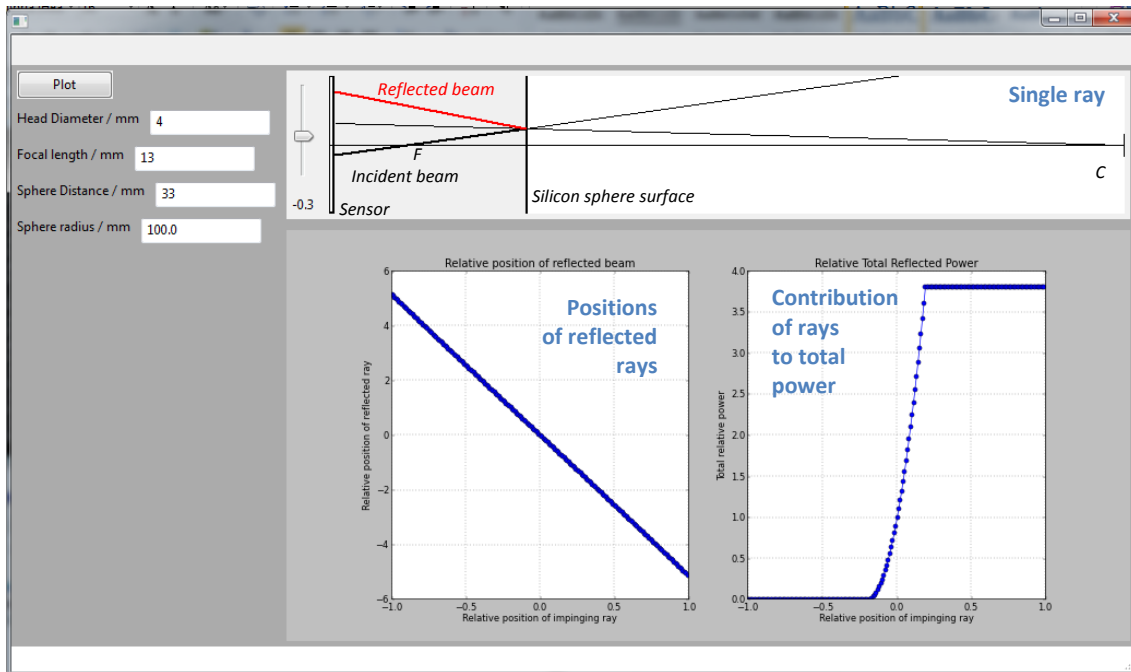

FIGURE 6 - SIMULATION OF SENSOR HEAD - RAYTRACING

Sensor Head D4/F13

A standard Sensor Head D14F13 has been selected and a numerical simulation of the expected return power has been performed.

The parameters of the sensor have been substituted in the found relationship between the positions of the incident and reflected beams.

Thus the expected return power has been calculated for a 100 mm diameter sphere at a distance d from the sensor in the range from 20 mm to 40 mm.

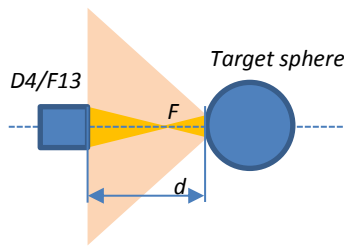

Sensor Heads	
product name	D4/F13
Modes of Operation	
optics type	focussing
dimensions	Ø 4 mm, length 11.5 mm
mounting	clamped
spot size	70 µm @ 13 mm
focal length	13 mm
connector	none (fiber glued)
working environment	
compatible targets	glass, silicon wafer, mirror
applications	various applications
Measurement Specifications	
measurement mode (target: glass)	single pass mode
linear measurement range (target: glass)	11.15 mm
alignment tolerance (target: glass)	± 0.35°
measurement mode (target: mirror)	single pass mode
linear measurement range (target: mirror)	30.45 mm
alignment tolerance (target: mirror)	± 0.35°
measurement mode (target: retroreflector)	-
linear measurement range (target: retroreflector)	-
alignment tolerance (target: retroreflector)	-
lateral alignment tolerance (target: retroreflector)	-

The expected 4 % power has been found at a distance close to 33 mm from the sensor.

In spite of the approximations (uniform instead of gaussian distribution of the beam intensity and unitary reflection coefficient of the target sphere), this result can be used as a starting point for the overall dimensioning of the measurement setup and for the sensor selection. Adjustments of the position of the sensor could be anyway necessary.

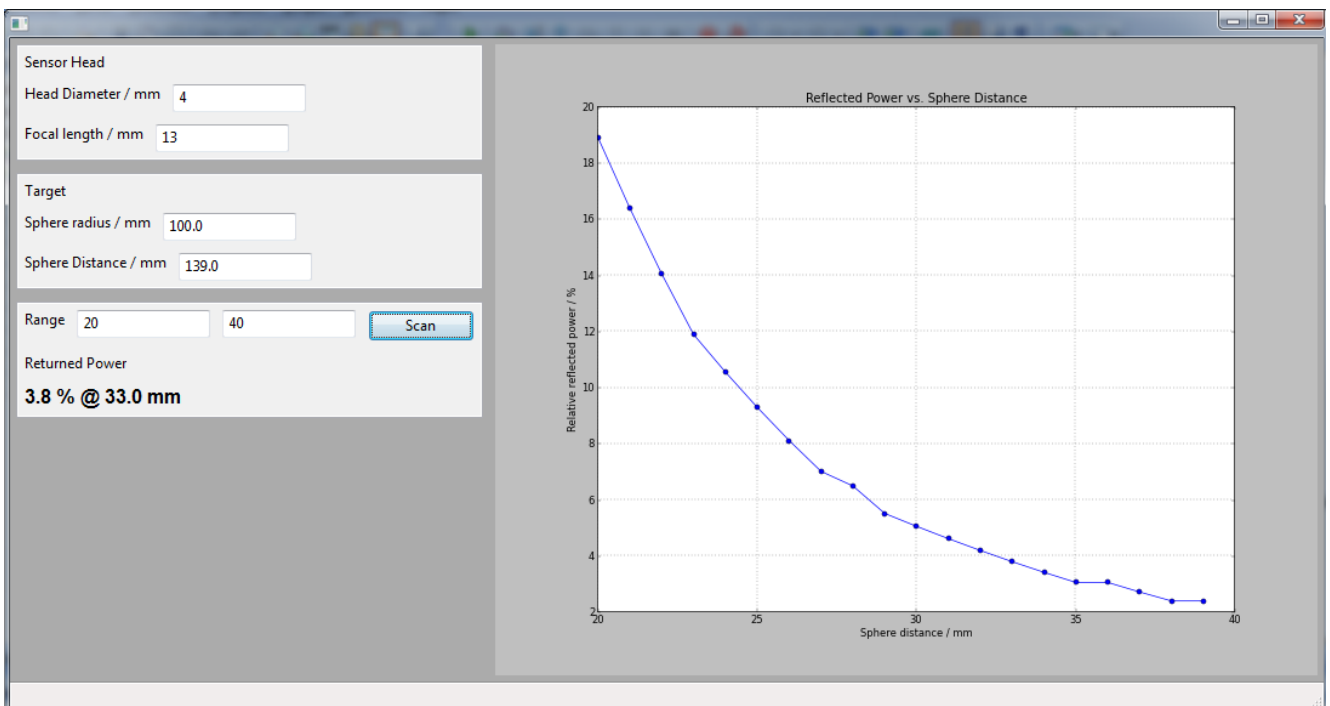

FIGURE 7 - SIMULATION OF THE RETURNED POWER

Instrument Interfacing

Ethernet connection

The onboard Ethernet link provides access the instrument settings and measurement results.

The network available services are

- Access through the integrated webserver
- Access through the .NET API
- Access though JSON-RPC

Access through the integrated webserver

For initial setup, the integrated webserver is preferred because it does not need additional software and works with common web browsers (i.e. Internet Explorer, Google Chrome and Firefox)

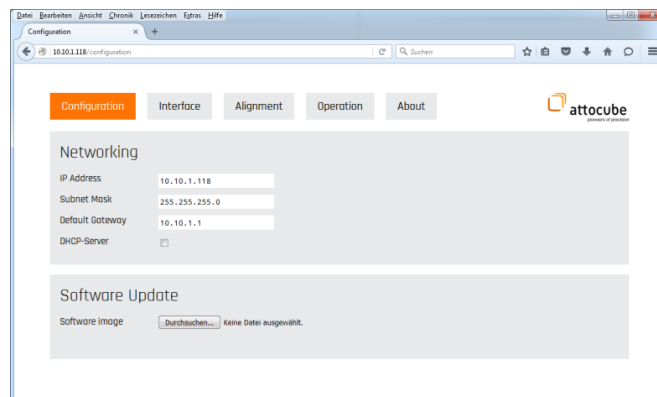

FIGURE 8 - INTEGRATED WEBSERVER

The instrument offers two network configurations (which apply to all the three network services).

- **Point to point** (default mode) – through the integrated DHCP server
This configuration allows the user to directly connect the instrument to a personal computer, having the network configuration handled by the instrument.
In spite of the simplicity, this solution grants access to all the services.
- **Infrastructure mode**
In this mode, the DHCP server is disabled because the instrument is intended to be connected to an existing network.
The network configuration of the instrument (IP address, netmask, default gateway) is set manually

**Warning: according to the specification, there is no way to reset the network configuration to a default state. So if a network parameter is set incorrectly, the instrument can become inaccessible.
In this situation, the manufacturer must be contacted to restore the correct configuration.**

Access through the .NET API

The .NET API allows to operate the instrument via the network by means of a set of functions which mimic the behaviour of the web interface. So, the user can configure the instrument parameters, ask the instrument to update its firmware, start a calibration, read the measurement results, etc.

This service is intended for use with custom written software.

Access through JSON-RPC

This access method, allows a user written software to send commands to the instrument and get replies back.

Data are exchanged through one of the following transport protocols: TCP, HTTP and WebSocket.

This means that the API is a higher level than the .NET API and it does not need linking a library to an executable. This allows to develop applications which just must have access to the network through one of the three cited protocols.

For example, using the HTTP protocol, the requirement to the user software is the capability to get URLs with the following scheme: `http://$(ipAddress):$(port)/api/json`

Although testing on a real instrument should be performed first, JSON-RPC on HTTP access seems to fit the needs as it allows to better integrate the software into an existing acquisition system.

Realtime Interface Connector

When measurement speed is an issue, the instrument provides access to the realtime measurements at high speed through a dedicated connector.

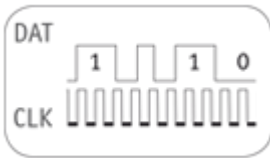

FIGURE 9 - REALTIME OUTPUTS CONNECTOR

Depending on the software configuration, this signals are available

- HSSL LVTTTL
- HSSL LVDS
- AquadB LVTTTL
- AquadB LVDS
- Sine and Cosine Analog signal (with LVTTTL Error Signal)
- Sine and Cosine Analog signal (with LVDS Error Signal)

A brief description of the signals follows.



HSSL (digital; bandwidth up to 25 MHz and 8-48 bit resolution): attocube's proprietary serial word protocol provides absolute position information - both in terms of the protocol and the measurement itself. The HSSL interface consists of one data and one clock signal (single ended or differential); position information is packed into one container of user-defineable bit-length, synchronization with

the receiver is accomplished using the clock signal. The HSSL protocol is preferential if absolute displacement position data (i.e. sensor-target separation) is required or if incremental position counting is unacceptable.

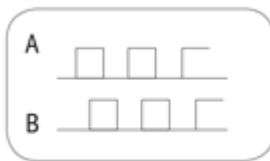

AquadB (digital; bandwidth up to 25 MHz; resolution freely assignable): The AquadB interface provides incremental displacement information on target displacement. Position resolution and (maximum) clock rate can be user defined using the software interface. For maximum data bandwidth, the AquadB interface is best used with differential signaling.

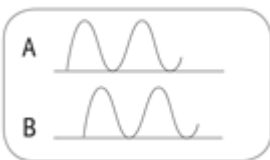

Sin/cos (analog; bandwidth up to 25 MHz; resolution freely assignable, 1pm - 224 pm): The sin/cos signal is a digitally synthesized analog signal which provides incremental position information. As with the digital AquadB signal, the increment (i.e. resolution) is user-definable in the system's web interface. For maximum data bandwidth, the sin/cos signal is best used with differential signaling.

All the three signals type require a dedicated hardware on the PC side. Nevertheless, some considerations on the signals must be made in order to design an efficient acquisition system.

HSSL is a high speed digital proprietary protocol. AquadB is digital but open.

In both situations, a digital acquisition card or a FPGA is needed to process the generated data.

Although the bitrate is not excessively high, HSSL is more suitable for acquisition by a Personal Computer because it provides absolute readings. On the other hand, the AquadB signal, which is incremental, could be easily acquired by a low cost FPGA board. The missing information on the initial absolute position could be sent to the FPGA by the PC, after reading it through the network.

Using the sin/cos signals does not provide advantages unless an analog to digital conversion board already exists in the acquisition system – for example for CNC controls [2] . This solution, otherwise, is quite expensive and yields incremental measurements which must be anyway integrated by network reading of data.

Integration of the IDS3010 in a Measurement Setup

Recalling the Realtime Outputs Connector pinout

Pin IDS top view	Pin 3M SDR Cable	Signal	HSSL LV TTL	HSSL LVDS	A-quad-B LV TTL	A-quad-B LVDS	Sin/Cos (error: LV TTL)	Sin/Cos (error: LVDS)
Axis 1								
21	blue (white)	POSITION-1A(+)	CL 1	CLK1(+)	1A	1A(+)	1A(+)	1A(+)
8	white (blue)	POSITION-1A(-)	-	CLK1(-)	-	1A(-)	1A(-)	1A(-)
22	green (white)	POSITION-1B(+)	DATA1	DATA1(+)	1B	1B(+)	1B(+)	1B(+)
9	white (green)	POSITION-1B(-)	-	DATA1(-)	-	1B(-)	1B(-)	1B(-)
23	yellow (white)	POSITION-1E(+)	-	-	1E	1E(+)	1E	1E(+)
10	white (yellow)	POSITION-1E(-)	-	-	-	1E(-)	-	1E(-)
Axis 2								
18	1 blue	POSITION-2A(+)	CLK2	CLK2(+)	2A	2A(+)	2A(+)	2A(+)
5	1 green	POSITION-2A(-)	-	CLK2(-)	-	2A(-)	2A(-)	2A(-)
19	3 brown	POSITION-2B(+)	DATA2	DATA2(+)	2B	2B(+)	2B(+)	2B(+)
6	3 black	POSITION-2B(-)	-	DATA2(-)	-	2B(-)	2B(-)	2B(-)
20	3 yellow	POSITION-2E(+)	-	-	2E	2E(+)	2E	2E(+)
7	3 green	POSITION-2E(-)	-	-	-	2E(-)	-	2E(-)
Axis 3								
15	2 brown	POSITION-3A(+)	CLK3	CLK3(+)	3A	3A(+)	3A(+)	3A(+)
2	2 black	POSITION-3A(-)	-	CLK3(-)	-	3A(-)	3A(-)	3A(-)
16	2 red	POSITION-3B(+)	DATA3	DATA3(+)	3B	3B(+)	3B(+)	3B(+)
3	2 green	POSITION-3B(-)	-	DATA3(-)	-	3B(-)	3B(-)	3B(-)
17	1 brown	POSITION-3E(+)	-	-	3E	3E(+)	3E	3E(+)
4	1 black	POSITION-3E(-)	-	-	-	3E(-)	-	3E(-)
GND								
12	black (red)	GND						
26	red (white)	GND						
13 + 14	inner shield	GND						
24	gold (white)	GND						
11	white (gold)	GND						
1	white (red)	GND						
25	red (black)	GPIO-RT						General purpose IO, always LV TTL levels (same circuit as on GPIO)

FIGURE 10 - REALTIME OUTPUTS CONNECTOR PINOUT

Both the HSSL (Single Ended) and AquadB (Single Ended) signals share the same terminals – see the blue dotted signals in Figure 10. An auxiliary pin is connected in AquadB mode for error handling, taking the pin count to 5 signals per channel.

This could allow to take advantage of a simple FPGA connecting to the 15 signals, which then is connected to the PC via a serial link.

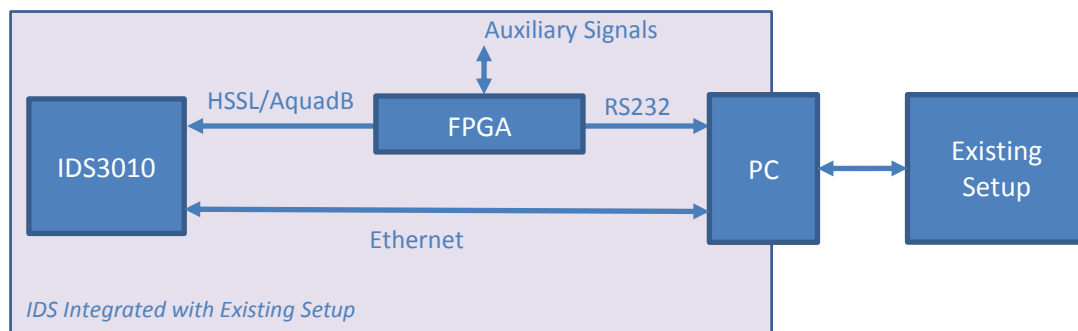

FIGURE 11 - ACQUISITION SYSTEM ARCHITECTURE

The advantages of an external programmable logic are

- Solution of the non-determinism problem of commercial Operating Systems when used in Acquisition Systems
- Reduction of overload the CPU of the Personal Computer which controls the experiment
- Reduction of data loss risk
- Testing different measurement solutions because the FPGA firmware can be easily reconfigured on the fly or changed offline in short times
- Availability of auxiliary digital signals if needed.
This would allow to generate or acquire auxiliary signals **synchronously** with the distance measurements

Conclusions

The results of the simulations of the deformation of a silicon sphere loaded with a test mass should be compared with accurate interferometric measurements. Thus, the available documentation and specifications of IDS3010 has been analysed to find whether the device can be integrated into an existing system designed for the validation of FEM simulations.

For low speed measurements, data can be collected from the instrument through a network connection via JSON-RPC.

For high measurement rates, an FPGA board could be used to overcome the need of a dedicated, and possibly expensive, acquisition board. In this case, the FPGA board would be used to interface the instrument to the PC thus allowing high speed movements of the target under measurements and reduction of data loss risk.

A software must be anyway developed to drive the instrument and the external logic board (is present) through the Ethernet connection and the RS232 serial link.

Appendix

Geometrical analysis of a ray reflected by a sphere

- A(0, a)
- B(0, b)
- C(c, 0)
- F(f, 0)
- P(c - R cos p, R sin p)

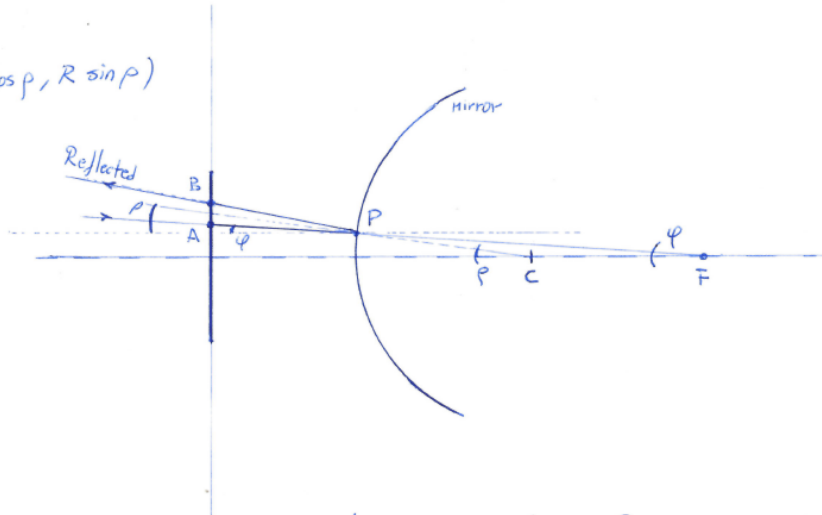

Ray from sensor A

$$y = a - \frac{a}{f}x$$

$$\varphi = \arctan \frac{a}{f}$$

Interception Ray-Sphere in P

$$R \sin p = a - \frac{a}{f}(c - R \cos p)$$

$$\sin p = \frac{a}{R} - \frac{c}{R} \tan \varphi + \cos p \tan \varphi$$

$$\sin p \cos \varphi - \cos p \sin \varphi = \frac{a}{R} \cos \varphi - \frac{a}{fR} \cos \varphi =$$

$$= \sin(p - \varphi) \quad \frac{a}{R} \cos \varphi - \frac{c}{R} \sin \varphi$$

$$\Rightarrow p = \arcsin\left(\frac{a}{R} \cos \varphi - \frac{c}{R} \sin \varphi\right) + \varphi$$

Return ray on B

$$b = R \sin p + c - R \cos p \tan \gamma$$

with $\gamma = 2p - \varphi$

References

- [1] Attocube, [Online]. Available: <http://www.attocube.com>.
- [2] Heidenhain Corporation, [Online]. Available: <http://www.heidenhain.com>.