



ISTITUTO NAZIONALE DI RICERCA METROLOGICA Repository Istituzionale

Uncertainty evaluation for complex GPS characteristics

Original

Uncertainty evaluation for complex GPS characteristics / Rosner, Paweł; Wojtyła, Mirosław; Gomez-Acedo, Eneko; Balsamo, Alessandro. - In: MEASUREMENT. SENSORS. - ISSN 2665-9174. - 18:(2021), pp. 1-4. [10.1016/j.measen.2021.100323]

Availability:

This version is available at: 11696/71976 since: 2021-11-21T19:35:15Z

Publisher:

Elsevier

Published

DOI:10.1016/j.measen.2021.100323

Terms of use:

This article is made available under terms and conditions as specified in the corresponding bibliographic description in the repository

Publisher copyright

(Article begins on next page)

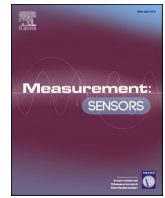

Uncertainty evaluation for complex GPS characteristics

ARTICLE INFO

Keywords

Coordinate measuring systems
Measurement uncertainty
Geometrical product specification
Sensitivity analysis
GUM uncertainty Framework

ABSTRACT

A proposal for estimating the uncertainty of coordinate measurements is presented, which can be applied in industrial conditions. The basis is the sensitivity analysis method supplemented with an experiment with the use of a non-calibrated object. The measuring task modelling procedure for complex geometrical characteristics is described. The results of research on the correlation of experimental results and the sensitivity analysis results are given.

1. Introduction

The accuracy of machine parts is described by a large number of different GPS (Geometrical Product Specification) characteristics [1,2]. As far as estimating the uncertainty of coordinate measurements is concerned, there is full agreement that the measurement uncertainties of different characteristics measured on the same coordinate measuring system (CMS) are different, and in some cases the differences can be significant [3]. Hence, emphasizing that a given technique is “task-specific”, both in publications and in the ISO 15530 standard (e.g. Ref. [4]) becomes redundant.

Numerous works on estimating the uncertainty of coordinate measurements focus on obtaining the highest possible accuracy of the results [5–7]. This requires taking into account very specific factors that may influence the uncertainty, such as the sampling strategy (number and location of sampling points, length and diameter of the stylus tip, scanning parameters), position and orientation of the object in the CMS space, temperature of the object and CMS standards, etc. the list can be found e.g. in Ref. [4]). Such a detailed approach justified for calibration laboratories is very often not possible in industrial conditions, where simple procedures are needed and less accurate results are enough.

At first glance, the use of calibrated workpieces [8] (but rather not use of “measurement standards”) technique is well suited for industrial applications. However, the condition for ease of use is that the “calibrated workpiece” form is identical. The main disadvantage is the high cost of making and calibrating the appropriate artefact. It should be remembered that in industrial measurements the object is placed in a specially designed holder and even slight differences in the design of this artefact with the workpiece may make it impossible to perform the experiment. It is less problematic to use one of the produced workpieces. However, even in the case of a workpiece with a complex design (engine body, camshaft, crankshaft), the calibration itself is cumbersome and expensive. By the way, it is worth noting that the earlier version of ISO 15530-3, i.e. the technical specification ISO/TS 15530-3:2004 [9,10], is better suited for industrial applications. The reason is the issue of the so-called systematic error, which is simply included in the measurement uncertainty in the ISO/TS 15530-3:2004.

The work [11] shows a universal way to estimate the uncertainty of coordinate measurements, namely modelling the measurement as an indirect measurement with the use of a mathematically minimal number of points enabling the definition of individual characteristics. These can be both surface points as well as axis or plane points and should represent the measurement strategy used, usually consistent with good measurement practice. These assumptions allow all particular geometric characteristics (dimensions, geometric deviations) to be expressed as functions of differences of workpiece points coordinates (it should be clearly emphasized that these are coordinate differences and not coordinates). Relations expressing the point-point, point-axis, point-plane distances [12] are particularly useful for this purpose.

In the same work, as in the classic virtual measuring machine (VCMM) [13], the residual (remaining after mathematical correction) geometric errors and head errors were used as information about the accuracy of the coordinate measuring machine (CMM). However, unlike VCMM, instead of simulation, type B evaluation was used, in which, based on the identified geometric errors, functions describing the maximum differences of geometric error values were determined. The arguments of these functions are differences of coordinates of workpiece points.

The concept of using a minimum number of points and models based on strict mathematical formulae expressing every individual geometrical characteristic as a function of the distances or differences in the coordinates of the pairs of points is continued in Refs. [14,15], where the use of the CMM kinematic model was abandoned. Instead, it was decided to use the CMS accuracy information contained in the formula on $E_{L,MPE}$. More specifically, the standard measurement uncertainty of coordinate differences is calculated according to the formula from Ref. [16]:

$$u = E_{L, MPE} \cdot b \quad (1)$$

This approach according to the classification of methods for estimating the uncertainty of coordinate measurements given in Ref. [17] is classified as sensitivity analysis, and according to GUM as GUM uncertainty framework [18,19].

This study analyses the possibility of the simultaneous use of the

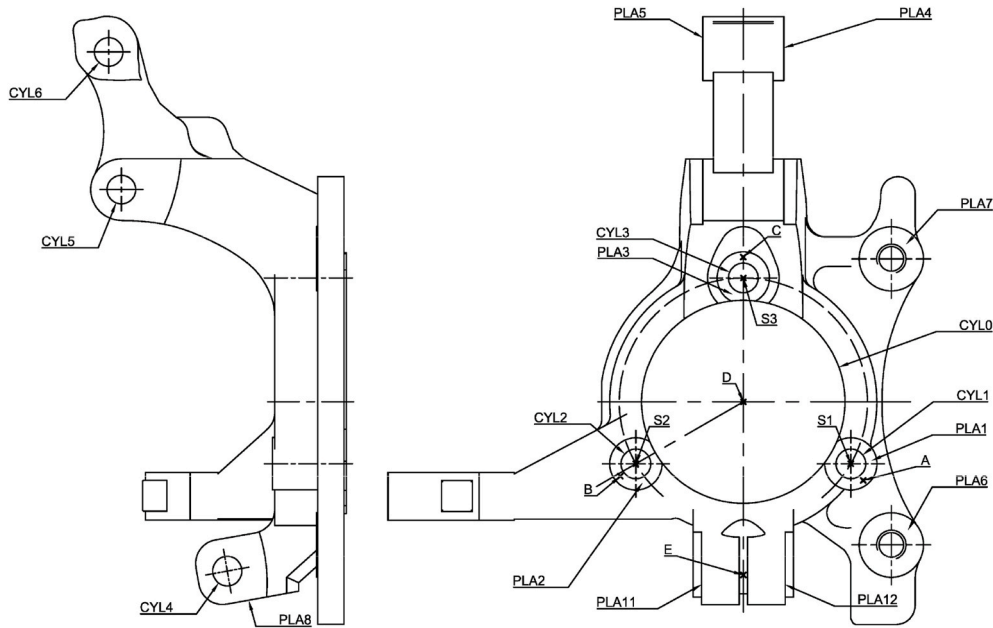

Fig. 1. Workpiece used in experiments with designation of the features and characteristic points.

results of an experiment similar to that described in ISO 15530-3, but performed on a non-calibrated object, and the methods of sensitivity analysis discussed in the works [14,15], in particular:

- the procedure for building a measurement model for complex GPS characteristics is described,
- the results of an experiment on a non-calibrated object and the correlation between the results of the sensitivity analysis calculations and the experiment are described.

2. Measurement models

A workpiece with a complex spatial form – a steering knuckle – was used for the research (Fig. 1).

34 different characteristics have been distinguished, including:

- circles diameters,
- flatness,
- parallelism of planes,
- position of axis in regard to datum plane,
- position of axis in regard to system of 2 and 3 datum features,
- perpendicularity of axis in regard to datum plane,
- symmetry,
- concentricity.

For most of the characteristics mentioned, suitable models can be found in Refs. [14,15]. In this paper we will focus on one example – the position of the hole axis in regard to the datum system.

The datum system consists of:

- primary datum – common plane of 3 planes PLA1, PLA2 and PLA3 (Fig. 1),
- secondary datum – axis of the hole CYL0 (Fig. 1),
- tertiary datum – symmetry plane of planes PLA11 and PLA12 (Fig. 1).

The tolerated features are the axes of holes CYL1, CYL2 and CYL3 (position tolerance, cylindrical tolerance zone). The plane constituting the primary datum is defined by 3 points marked in Figures as A, B and C. The plane constituting the secondary datum is perpendicular to the

primary datum and includes points D (the hole axis point) and E (the symmetry plane point). The plane which is the tertiary datum is perpendicular to the primary and secondary datums and contains point D. Toleranced elements (axes of holes) will be represented by points S₁, S₂ and S₃ (in general notation – point S).

Normal vectors of the planes mentioned are needed for further calculations. The normal vector *u* of the primary datum can be calculated as the vector product of the vectors AB and AC:

$$u = AB \times AC \quad (2)$$

Normal vector *v* of the secondary datum can be calculated as the vector product of vector *u* and vector DE:

$$v = u \times DE = (AB \times AC) \times DE \quad (3)$$

The normal vector *w* of tertiary datum can be calculated as the vector product of vectors *u* and *v*:

$$w = u \times v = (AB \times AC) \times ((AB \times AC) \times DE) \quad (4)$$

The distance of the hole's axis from the secondary datum can be calculated by the formula

$$l_1 = \left| ES \cdot \frac{(AB \times AC) \times DE}{|(AB \times AC) \times DE|} \right| \quad (5)$$

which shows that this distance is a function of 12 input quantities, which are the coordinates of the 4 vectors in the formula.

The position of the hole's axis relative to the secondary datum is (according to Ref. [1]) equal to twice the absolute value of the difference of the distance *l*₁ and the corresponding theoretically exact dimension value *l*_{1TED}

$$POS_1 = 2 \cdot |l_1 - l_{1TED}| \quad (6)$$

The distance of the hole's axis from the tertiary datum can be calculated by the formula

$$l_2 = \left| DS \cdot \frac{(AB \times AC) \times ((AB \times AC) \times DE)}{|(AB \times AC) \times ((AB \times AC) \times DE)|} \right| \quad (7)$$

which shows that this distance is a function of 15 input quantities, which are the coordinates of the 5 vectors in the formula.

The position of the hole's axis relative to the tertiary datum is equal

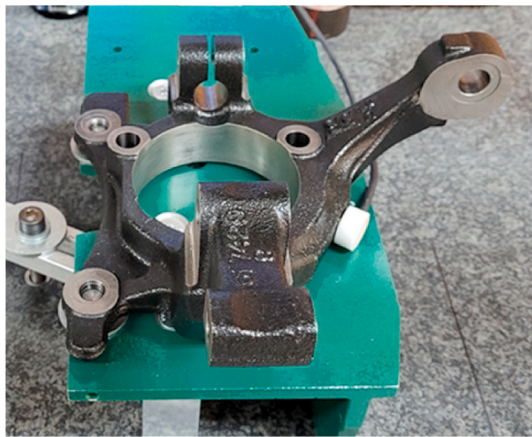

Fig. 2. Workpiece in experiments – one of the “horizontal” orientations.



Fig. 3. Workpiece in experiments – “vertical” orientation.

to twice the absolute value of the difference of the distance l_2 and the corresponding theoretically exact dimension value l_{2TED}

$$POS_2 = 2 \cdot |l_2 - l_{2TED}| \tag{8}$$

Position of the axis in regard to the datum system for the case of the cylindrical tolerance zone is defined as the double value of the observed distance of the axis from its theoretically exact position, i.e. it can be calculated according to the formula:

$$POS = 2\sqrt{(l_1 - l_{1TED})^2 + (l_2 - l_{2TED})^2} \tag{9}$$

This distance is also a function of the 15 input quantities.

According to the sensitivity analysis technique, the standard uncertainty of measurement of individual characteristics is calculated according to the formula:

Table 1
Selected results of experiment.

Characteristics	Sensitivity analysis u , μm	Experiment s , μm
Diameter B	1.6	1.9
Diameter_CIR_1	1.5	1.9
Diameter_CIR_2	1.5	2.0
Diameter_CIR_3	1.5	1.6
Perpendicularity_B_A	2.0	2.1
Flatness_A	1.0	0.6
Flatness_H	1.0	0.8
Perpendicularity_D-A	2.2	1.4
Parallelism_PlaG1G2	1.4	1.7
Parallelism_CylW-G	1.4	1.5

$$u_c = \sqrt{\sum_{i=1}^k \left(\frac{\partial l}{\partial x_i} u_{x_i} \right)^2} \tag{10}$$

where k is the number of input quantities and x_i are the individual quantities, and u_{x_i} are the standard measurement uncertainties of the individual distances x_i calculated according to formula (1).

As mentioned in the introduction, an important issue is the correct selection of characteristic points. These should be points distributed in accordance with good measurement practice, which means that they should cover individual features as widely as possible and should be as far away from the datums as possible.

3. Experiment

Measurements were carried out on CMM MicroXcel PFx 765 with TP20 probing head for which $E_{L,MPE}$ formula is:

$$E_{L,MPE} = 3 + 4L/1000 \tag{11}$$

The experimental part consists of measurements of the non-calibrated object carried out according to the procedure described in ISO 15530-3, i.e. 21 measurements spread over time were made. The measurements were performed in 3 different orientations of the workpiece: two “horizontal” (Fig. 2) and one “vertical” (Fig. 3). In each orientation measurement was repeated 7 times.

Standard deviations were calculated for all characteristics. The obtained results were compared with the results of the calculations described in the previous chapter. Selected results are presented in Table 1.

The correlation coefficient was calculated for the obtained results. The value was 0.74.

4. Conclusions

The models for estimating the uncertainty of coordinate measurements using the sensitivity analysis technique, based on the formulas for the point-straight and point-plane distance, provided in Refs. [14,15], can be easily generalized for any complex characteristic, as shown on the example of the position of the hole axis in regard to the system of three datums.

An experiment similar to that described in ISO 15530-3, performed on a non-calibrated workpiece, can be used to verify the results obtained computationally based on the information contained in the formula for $E_{L,MPE}$.

The proposed method is universal. Applies to all CMS for which the $E_{L,MPE}$ formula for length measurements is known.

Acknowledgments

The presented work is part of the EMPIR EURAMET-founded joint research project no. 17NRM03 “Standards for the evaluation of the uncertainty of coordinate measurements in industry EUCoM”

coordinated by Alessandro Balsamo, INRIM [20].

References

- [1] ISO 1101:2017 Geometrical product specifications (GPS). Geometrical tolerancing. Tolerances of form, orientation, location and run-out.
- [2] Z. Humienny, State of art in standardization in the geometrical product specification area a decade later, CIRP Journal of Manufacturing Science and Technology 33 (2021) 42–51.
- [3] D. Flack, “Co-ordinate Measuring Machine Task-specific Measurement Uncertainties”, Good Practice Guide No. 130. NPL, 2013.
- [4] ISO/TS 15530-4, Geometrical Product Specifications (GPS). Coordinate Measuring Machines (CMM): Technique for Determining the Uncertainty of Measurement Part 4: Evaluating Task-specific Measurement Uncertainty Using Simulation, 2008.
- [5] A. Forbes, Uncertainties associated with position, size and shape for point cloud data, IOP Conf. Series: J. Phys. Conf. 1065 (2018), <https://doi.org/10.1088/1742-6596/1065/14/142023>.
- [6] A. Jalid, S. Hariri, N.E. Laghzale, Influence of sample size on flatness estimation and uncertainty in three-dimensional measurement, Int. J. Metrol. Qual. Eng. 6 (2015) 102, <https://doi.org/10.1051/ijmqe/2015002>.
- [7] H. Li, X. Chen, Y. Cheng, H. Liu, H. Wang, Z. Cheng, H. Wang, Uncertainty modeling and evaluation of CMM task oriented measurement based on SVCMM, Meas. Sci. Rev. 17 (No. 5) (2017) 226–231.
- [8] ISO 15530-3, Geometrical Product Specifications (GPS). Coordinate Measuring Machines (CMM): Technique for Determining the Uncertainty of Measurement Part 3: Use of Calibrated Workpieces or Measurement Standards, 2011.
- [9] ISO/TS 15530-3, Geometrical Product Specifications (GPS). Coordinate Measuring Machines (CMM): Technique for Determining the Uncertainty of Measurement. Part 3: Use of Calibrated Workpieces or Standards, 2004.
- [10] B. Štrbac, B. Acko, S. Havrlišan, I. Matin, B. Savkovic, M. Hadzistevec, Investigation of the effect of temperature and other significant factors on systematic error and measurement uncertainty in CMM measurements by applying design of experiments, Measurement 158 (2020) 107692.
- [11] W. Jakubiec, W. Płowucha, M. Starczak, “Analytical Estimation of Coordinate Measurement Uncertainty”, Measurement vol. 45, 2012, pp. 2299–2308.
- [12] ISO 17450-1, Geometrical Product Specifications (GPS). General Concepts Part 1: Model for Geometrical Specification and Verification, 2011.
- [13] D. Heisselmann, M. Franke, K. Rost, K. Wendt, Determination of measurement uncertainty by Monte Carlo simulation, Adv. Mathemat. Computational Tools Metrol. Testing XI (2018) 192–202.
- [14] W. Płowucha, Point-straight line distance as model for uncertainty evaluation of coordinate measurement, Measurement 135 (2019) 83–95.
- [15] W. Płowucha, Point-plane distance as model for uncertainty evaluation of coordinate measurement, Metrol. Meas. Syst. 27 (No. 4) (2020) 625–639.
- [16] ISO 14253-2, Geometrical Product Specifications (GPS). Inspection by Measurement of Workpieces and Measuring Equipment Part 2: Guidance for the Estimation of Uncertainty in GPS Measurement, in Calibration of Measuring Equipment and in Product Verification, 2011.
- [17] ISO/TS 15530-1, Geometrical Product Specifications (GPS). Coordinate Measuring Machines (CMM): Technique for Determining the Uncertainty of Measurement. Part 1: Overview and Metrological Characteristics, 2013.
- [18] JCGM 100, Evaluation of Measurement Data. Guide to the Expression of Uncertainty in Measurement, 2008.
- [19] B. Štrbac, V. Radlovački, V. Spasic-Jokic, M. Delic and M. Hadzistevec, “The difference between GUM and ISO/TC 15530-3 method to evaluate the measurement uncertainty of flatness by a CMM”, MAPAN-J. Metrol. Soc. India, DOI 10.1007/s12647-017-0227-3.
- [20] <https://eucom-empir.eu/>. (Accessed 18 April 2021) accessed on.

Paweł Rosner*, Mirosław Wojtyła
*University of Bielsko-Biala (Laboratory of Metrology), Bielsko-Biala,
 Poland*

Eneko Gomez-Acedo
Tekniker, Eibar, Spain
E-mail address: eneko.gomez-acedo@tekniker.es.

Alessandro Balsamo
INRIM (National Institute of Research in Metrology), Torino, Italy
E-mail address: a.balsamo@inrim.it.

* Corresponding author.
*E-mail addresses: prosner@ath.bielsko.pl (P. Rosner), lm@ath.bielsko.pl
 (M. Wojtyła).*