



## ISTITUTO NAZIONALE DI RICERCA METROLOGICA Repository Istituzionale

Supplementary comparison EURAMET.EM-S35: comparison of high-current ratio standard.  
Final report.

*Original*

Supplementary comparison EURAMET.EM-S35: comparison of high-current ratio standard. Final report / Cassiago, C.; Mortara, A.. - In: METROLOGIA. - ISSN 0026-1394. - 57:1A(2020), pp. 01004-01004. [10.1088/0026-1394/57/1a/01004]

*Availability:*

This version is available at: 11696/61735 since: 2025-02-21T12:40:29Z

*Publisher:*

BIPM & IOP Publishing Ltd

*Published*

DOI:10.1088/0026-1394/57/1a/01004

*Terms of use:*

This article is made available under terms and conditions as specified in the corresponding bibliographic description in the repository

*Publisher copyright*

BIPM  
Copyright © BIPM. The BIPM holds copyright on the textual and multimedia information available on BIPM website, which includes titles, slogans, logos and images, unless otherwise stated. All commercial use, reproduction or translation of textual and multimedia information and/or of the logos, emblems, publications or other creations contained therein, requires the prior written permission of the BIPM.

(Article begins on next page)

# **Supplementary Comparison EURAMET.EM-35 Comparison of High-Current Ratio Standard**

## **FINAL REPORT**

C. Cassiago<sup>a</sup> and A. Mortara<sup>b</sup>

a Istituto Nazionale di Ricerca Metrologica, INRIM  
Strada delle Cacce 91, 10135 Turin, Italy

b Federal Institute of Metrology, METAS  
Lindenweg 50, 3003 Bern-Wabern, Switzerland

## Table of Contents

1.	Introduction .....	3
2.	Participants and organisation of the comparison.....	3
2.1	Co-ordinator and members of the support group .....	3
2.2	List of participants .....	4
2.3	Organisation and comparison schedule.....	4
2.4	Unexpected incidents .....	5
3.	Travelling standard and measurement instructions.....	6
3.1	Description of the standards.....	6
3.2	Quantities to be measured and conditions of measurement.....	6
3.3	Measurement instructions .....	7
3.4	Deviations from the protocol .....	7
4.	Methods of measurement .....	7
5.	Repeated measurements of the pilot institute, behaviour of the travelling standards.....	7
5.1	Temperature dependence .....	7
5.2	Drift behaviour of the standards.....	9
6.	Analysis of comparison data set.....	9
6.1	Basic strategy .....	9
6.2	Results of the participating institutes .....	9
6.3	Normalization of the results .....	15
6.4	Calculation of the reference value and its uncertainty.....	15
6.5	Degrees of equivalence of the participating institutes .....	17
6.6	Link to the CCEM KC and degrees of equivalence.....	19
7.	Changes with respect to draft A version 2.0 .....	19
7.1	Changes requested by the participants .....	19
7.2	Changes and corrections by the pilot laboratory.....	19
8.	Summary and conclusions.....	19
9.	References .....	20

### Annexes

- A Measurement results reported by the participants
- B Methods of measurement
- C Uncertainty budgets
- D Technical protocol of the comparison
- E Datasheet of travelling standard

## 1. Introduction

This is the Draft B report of the EURAMET comparison EURAMET.EM-S35, “Comparison of High-Current Ratio Standard” (Reg. No. 1217).

<b>Metrology area, branch</b>	Electricity and Magnetism, DC Voltage and Current
<b>Description</b>	High DC current ratio
<b>Time of measurement</b>	2012-2015
<b>Status</b>	Draft B
<b>Reference(s)</b>	no references available
<b>Measurand</b>	Nominal current ratio: 1:1500
<b>Parameter(s)</b>	Primary current nominal values: 90 A, 300 A and 600 A
<b>Transfer device(s)</b>	Commercial zero-flux current transformer
<b>Comparison type</b>	Supplementary comparison
<b>Consultative Committee</b>	CCEM (Consultative Committee for Electricity and Magnetism) EURAMET (formerly EUROMET) (European Association of National Metrology Institutes)

The primary scope of the comparison was the validation of NMI CMCs for quantities related to dc high currents (CMC classification 8.7.1, 8.7.2 and 8.7.3), for current values in the range 100 A – 600 A.

Previous CCEM and EUROMET comparisons on dc current do not cover the current range exploited in the present comparison.

## 2. Participants and organisation of the comparison

### 2.1 Co-ordinator and members of the support group

The pilot laboratories for the comparison were METAS and INRIM.

Co-ordinator:

Cristina Cassiago  
Tel.: +39 011 3919430; e-mail: c.cassiago@inrim.it

Support group, appointed by the EURAMET technical committee for electricity and magnetism:

Alessandro Mortara (METAS)  
e-mail: alessandro.mortara@metas.ch

Bernd Schumacher (PTB)  
e-mail: bernd.schumacher@ptb.de

JT Janssen (NPL)  
e-mail: jt.janssen@npl.co.uk

## 2.2 List of participants

No	Country	Institute	Acronym
1	Belgium	SPF Economie, PME, Classes Moyennes et Énergie - Qualité et Sécurité- Service Etalons	SMD <sup>(1)</sup>
2	Czech Republic	Czech Metrology Institute	CMI
3	Finland	Centre for Metrology and Accreditation	MIKES
4	France	Laboratoire national de métrologie et d'essais	LNE
5	Germany	Physikalisch-Technische Bundesanstalt	PTB
6	Italy	Istituto Nazionale di Ricerca Metrologica	INRIM
7	Netherlands	VSL Dutch Metrology Institute	VSL
8	Slovenia	Slovenian Institute of Quality and Metrology	SIQ
9	Spain	Laboratorio Central Oficial de Electrotecnia	LCOE <sup>(2)</sup>
10	Sweden	SP Technical Research Institute of Sweden	SP
11	Switzerland	Federal Institute of Metrology METAS	METAS
12	United Kingdom	National Physical Laboratory	NPL <sup>(3)</sup>

**Table 1:** Participants

## 2.3 Organisation and comparison schedule

The comparison was carried out in 2 loops with 2 travelling standards of identical model and nominal value, one provided by METAS for the 1<sup>st</sup> loop, and the other one provided by INRIM for the 2<sup>nd</sup> loop. The circulation of the standards started in December 2012 and was completed in June 2015. The detailed time schedule for the comparison is given in Table 2.

A period of four weeks was originally allowed for the measurements in each laboratory, including the time necessary for transportation. The standards were re-measured at the end of each loop in the pilot laboratory to establish a drift rate for the standards and to detect value changes related to transport.

To inform each participant on the state of the comparison, and provide other useful information, the web page **EM-S35.schedule**, with controlled access, was created on Google Sites (<https://sites.google.com/a/inrim.it/em-s35schedule/>)

(1) On February 2014 SMD withdrew from the comparison because, due to technical problems, it could not guarantee the traceability of its measurement system in time to perform the comparison.

(2) On October 2013 LCOE joined the comparison.

(3) On September 2016 NPL withdrew from the comparison because of technical incompatibility between the travelling standards and its measurement system based on CCC bridge.

Institute	Country	Mean date of measurements	Time for measurements and transport (weeks)	Loop	Standard owner
<b>METAS</b>	Switzerland	10-12-2012	7.3	1	METAS
<b>SP</b>	Sweden	31-01-2013	6.3		
<b>VSL</b>	Netherlands	24-02-2013	4.6		
<b>PTB</b>	Germany	18-03-2013	3.1		
<b>LNE</b>	France	17-04-2013	5.4		
<b>METAS</b>	Switzerland	14-05-2013	5.3 <sup>(4)</sup>		
<b>INRIM</b>	Italy	15-06-2013	1.4 <sup>(5)</sup>	2	INRIM
<b>NPL</b>	United Kingdom	---	11.6 <sup>(6)</sup>		
<b>INRIM</b>	Italy	19-09-2013	13.6 <sup>(7)</sup>		
<b>MIKES</b>	Finland	22-01-2014	7.4 <sup>(8)</sup>		
<b>CMI</b>	Czech Republic	01-03-2014	7.4 <sup>(9)</sup>		
<b>NPL</b>	United Kingdom	---	6.1 <sup>(10)</sup>		
<b>SIQ</b>	Slovenia	---	4.7		
<b>LCOE</b>	Spain	01-04-2014	14.9 <sup>(10)</sup>		
<b>METAS</b>	Switzerland	01-11-2014	17.4 <sup>(11)</sup>		
<b>INRIM</b>	Italy	12-03-2015	17.6 <sup>(12)</sup>		
<b>SIQ</b>	Slovenia	12-06-2015	4		
<b>INRIM</b>	Italy	08-07-2015	4		

**Table 2:** Comparison schedule  
(more details in <https://sites.google.com/a/inrim.it/em-s35schedule/home/schedule>)

## 2.4 Unexpected incidents

At the beginning of 2<sup>nd</sup> loop the METAS standard was delayed for a week in the transport from Switzerland to Italy. Therefore only a quick check was performed by INRIM to avoid further delay in the schedule of the second loop. But the NPL found a strong instability of this first standard, so METAS and INRIM decided by mutual consent the withdrawal of the METAS standard, substituting it with another one of the same model and value provided and characterized by INRIM.

Later tests performed by INRIM and METAS on the METAS standard did not reveal the instability as seen by NPL, probably related to their measurement system.

Moreover, the INRIM standards showed a malfunction at the end of 2<sup>nd</sup> loop for 600 A in positive polarity, but this fact did not influence the comparison results.

(4) 15 days of delay caused by Italian customs.

(5) Quick measure at INRIM to compensate the delay on METAS standard.

(6) NPL reporting significant problems in the behaviour of METAS standard; pilots decided for its substitution.

(7) Characterization of the INRIM travelling standard. Further 15 days of delay in shipment due to Italian strikes.

(8) Delay due to Christmas holidays.

(9) Delay due to unavailability of the CMI contact person.

(10) Delay due to unknown causes.

(11) METAS required a supplementary measurement time.

(12) On July 2014 pilots granted a supplementary measurement session to SIQ (scheduled for the end of May 2015) for completing the protocol requirements.

### 3. Travelling standard and measurement instructions

#### 3.1 Description of the standards

- Type : LEM IT-600 S
- Nominal primary current : 0 - 600 A
- Nominal primary to secondary current ratio : 1:1500
- Power supply : 0 V, and  $\pm 15$  V

The travelling standard is a zero flux current transformer with embedded electronics. Mechanical and connection details are given in Annex E.

Loop	Value	Standards	ID
1	1/1500	LEM IT-600 S	UCLEM: 71.35.52.000.0 DF no.: 8100088322 Serial no.: Sample METAS
2	1/1500	LEM IT-600 S	UCLEM: 71.35.52.000.0 DF no.: 8100088322 Serial no.: 9112230053

**Table 3:** List of travelling standards

#### 3.2 Quantities to be measured and conditions of measurement

- Current ratio<sup>(13)</sup> :  $R = 1:1500$  (measurand)

It is the secondary to primary current ratio, and was defined as follows:

$$R = \frac{I_S - I_{\text{off}}}{I_p} \quad (1)$$

where  $I_p$  is the input current (primary current) flowing in the travelling standard and  $I_S$  the output current (secondary current) of the travelling standard.  $I_{\text{off}}$  is the output current of the travelling standard when the input current is zero.

The value of  $R$  should have been measured for both polarities at a given current value.

- Primary current<sup>(13)</sup> : 90 A (mandatory), 300 A and 600 A (optional)
- Secondary current<sup>(13)</sup> : 60 mA (mandatory), 200 mA and 400 mA (optional)
- Supply voltage<sup>(13)</sup> : 0 V and  $\pm 15$  V

The supplied values should not have been more than 5% away from the nominal value.

The measured power supply values had to be provided together with the measurement results.

- Temperature :  $(23 \pm 1)$  °C

The temperature should not have exceeded the given limits.

It had to be measured on the primary current bus bar, as close as possible to the measuring head.

---

(13) Nominal values.

- Humidity<sup>(14)</sup> :  $(50 \pm 10)$  %.

### 3.3 Measurement instructions

Pre-conditioning : the travelling standard should have been powered during at least 24 hours in laboratory conditions before starting measurements.

The recommended value for load resistance  $R_m$ <sup>(15)</sup> was  $1 \Omega$ , however it had not to exceed  $2.5 \Omega$

Measurements : the measurement results of  $R$  should be given as

$R_+$  = measurement performed with positive current<sup>(16)</sup>,

$R_-$  = measurement performed with negative current,

$R_M$  = result obtained by averaging  $R_+$  and  $R_-$  measurements or measured in other way (for instance with a direct measurement). In this last case, if  $R_+$  and  $R_-$  could not be evaluated independently it had to be declared.

Method : the measurement method was not specified, it was assumed that every participant uses its normal measurement method. The method and the traceability scheme had to be described in the measurement report.

### 3.4 Deviations from the protocol

The comparison was carried out as described in the protocol. Except for the modifications in the comparison schedule, no adjustments of the protocol were necessary.

## 4. Methods of measurement

A short description of the methods of measurement and the step-up procedures used by each participant is given in Annex B.

## 5. Repeated measurements of the pilot institute, behaviour of the travelling standards

### 5.1 Temperature dependence

Fig. 1 and 2 give an example of behaviour of both travelling standards, where the result of consecutive series of measurement of  $R_M$  versus the bus bar temperature are reported: for both travelling standards the variations are of a few parts in  $10^7$ , and a no significant trend is visible. Thus no temperature correction was applied.

The results in the figures are shown as the relative error of  $R_M$  with respect to the nominal value of  $R$

$$\delta R_M = \frac{R_M - R_{\text{nom}}}{R_{\text{nom}}} \quad (2)$$

(14) No characterization was done for humidity and pressure quantity, because no significant influence was expected.

(15) See Annex E.

(16)  $I_S$  is considered positive when  $I_p$  flows in the direction of the arrow on top of the travelling standard (see Annex E).

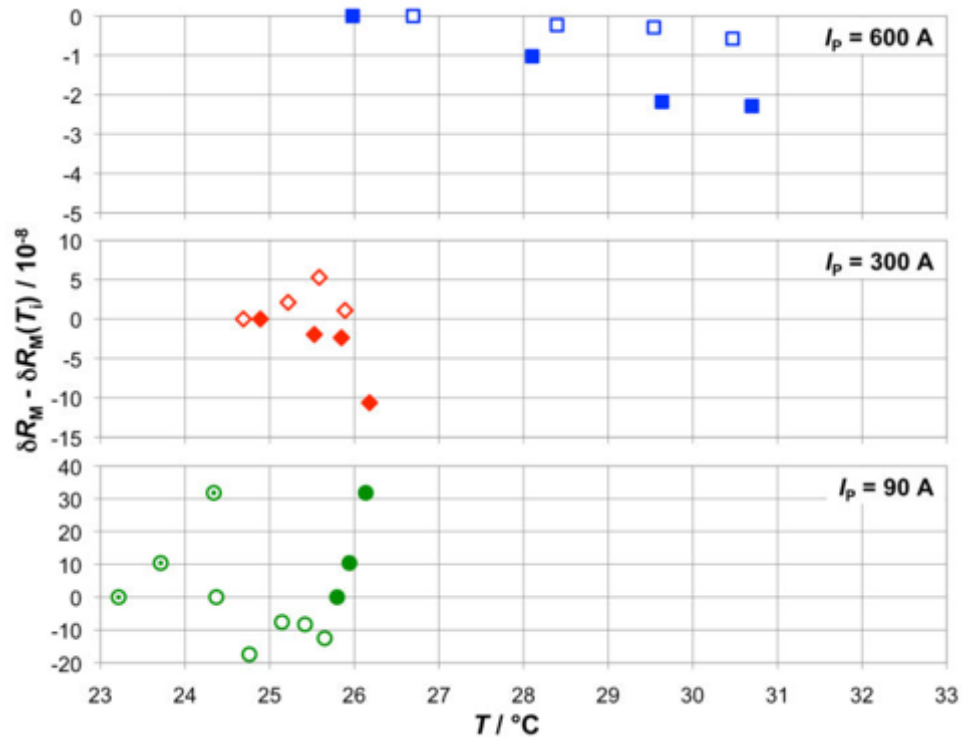

**Figure 1:** Behaviour of  $R_M$  of METAS LEM vs bus bar temperature.

- , ⊙, ● : results of 3 different series of consecutive measurements at  $I_p = 90$  A.
  - ◇, ◆ : results of 2 different series of consecutive measurements at  $I_p = 300$  A.
  - , ■ : results of 2 different series of consecutive measurements at  $I_p = 600$  A.
- $\delta R_M$  : relative error of  $R_M$  with respect to the nominal value of  $R$ .  
 $\delta R_M(T_i)$  : value of  $\delta R_M$  at initial temperature  $T_i$  of bus bar for each series.

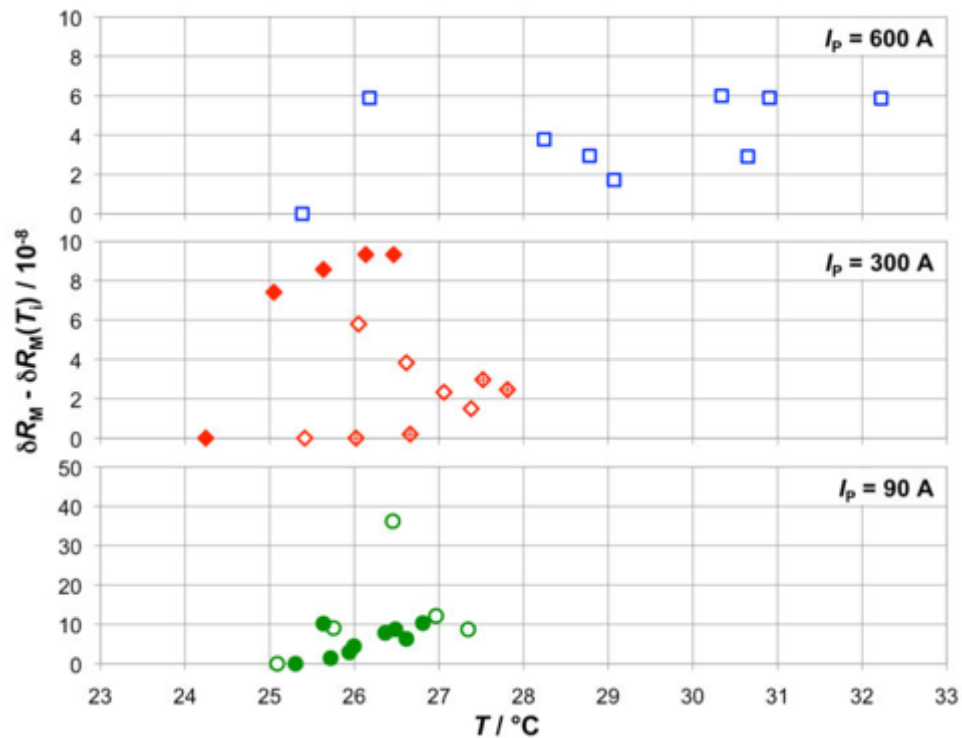

**Figure 2:** Behaviour of  $R_M$  of INRIM LEM vs bus bar temperature:

- , ● : results of 2 different series of consecutive measurements at  $I_p = 90$  A.
  - ◇, ◆, ◆ : results of 3 different series of consecutive measurements at  $I_p = 300$  A.
  - : results of 1 long series of consecutive measurements at  $I_p = 600$  A.
- $\delta R_M$  : relative error of  $R_M$  with respect to the nominal value of  $R$ .  
 $\delta R_M(T_i)$  : value of  $\delta R_M$  at initial temperature  $T_i$  of bus bar for each series.

## 5.2 Drift behaviour of the standards

The measurements carried out at the beginning and the end of each comparison loop, revealed no appreciable drift of both travelling standard. For this reason no drift correction was applied.

## 6. Analysis of comparison data set

### 6.1 Basic strategy

The analysis of the data set consists of two main steps

1. normalization of results: the data set is relativized to nominal value of  $R$ ,
2. determination of comparison reference values and degrees of equivalence [1] from the corrected data set using a method of constrained least square optimization. This part follows the method described in [2, 3].

### 6.2 Results of the participating institutes

The participants were asked to do as many measurements as deemed reasonable distributed in time over the whole period allocated to the laboratory.

As requested, all participants measured the value of  $R$  at the primary current of 90 A, and most of them measured  $R$  also at 300 A and 600 A.

Moreover the pilot laboratories of the comparison measured  $R$  at three primary currents for both travelling standards.

Institute	$R^+$			$R^-$			$R_M$			Loop
	90 A	300 A	600 A	90 A	300 A	600 A	90 A	300 A	600 A	
SP							•	•		1
VSL	•	•	•	•	•	•	•	•	•	
PTB	•			•			•			
LNE	•	•	•	•	•	•	•	•	•	
METAS	•	•	•	•	•	•	•	•	•	
INRIM	•	•	•	•	•	•	•	•	•	
MIKES	•	•	•	•	•	•	•	•	•	2
CMI							•	•	•	
LCOE	•	•	•	•	•	•	•	•	•	
METAS	•	•	•	•	•	•	•	•	•	
INRIM	•	•	•	•	•	•	•	•	•	
SIQ	•	•		•	•		•	•		

**Table 4:** Measures of  $R$  performed by participants at the three values of primary current  $I_p$

For each measurement the following information was reported

- date of measurement
- primary current value with its uncertainty
- temperature value with its uncertainty
- humidity value with its uncertainty
- power supply voltage value, positive and negative, with its uncertainty
- power supply voltage variation
- ratio value, as  $R^+$ ,  $R^-$  and/or  $R_M$ , with its uncertainty

The results obtained by each participant for  $R^+$ ,  $R^-$  and  $R_M$  (with their expanded uncertainties) are reported in Annex A, and summarized in figures 3-6, as relative error with respect to the nominal value of  $R$ .

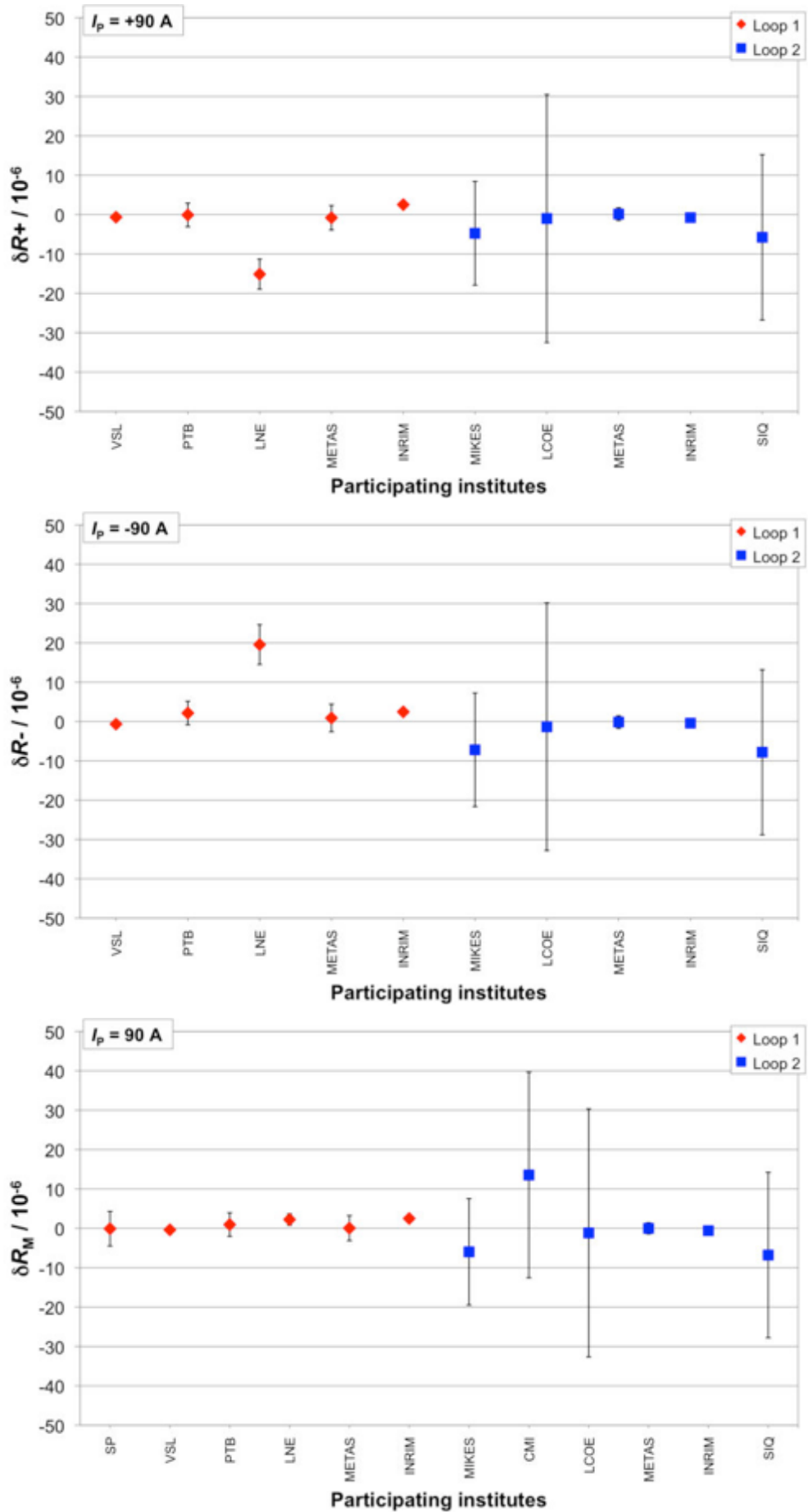

**Figure 3:** Relative errors of  $R_+$ ,  $R_-$  and  $R_M$  (with expanded uncertainties) with respect to the nominal value at 90 A.

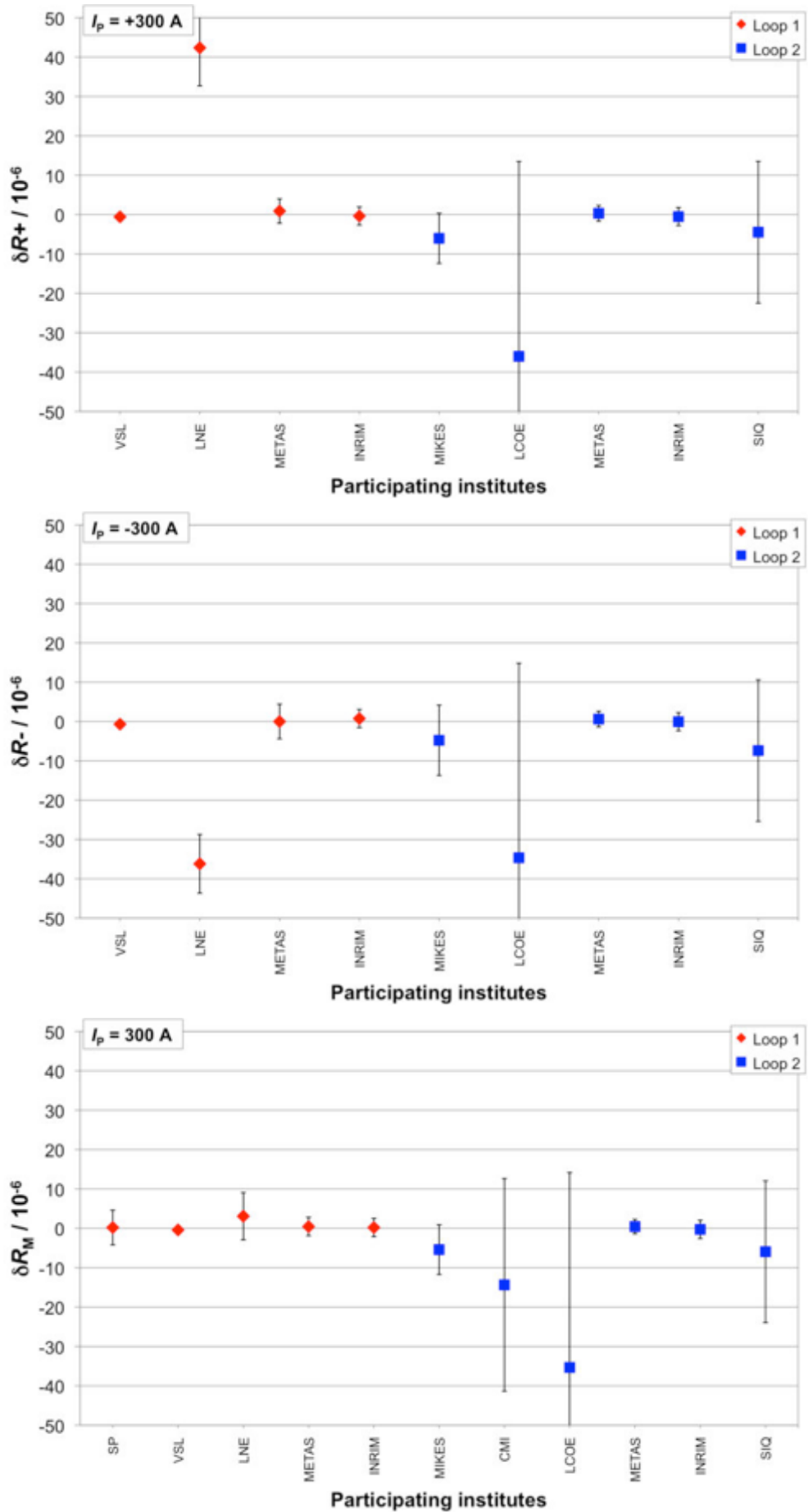

**Figure 4:** Relative errors of  $R_+$ ,  $R_-$  and  $R_M$  (with expanded uncertainties) with respect to the nominal value at 300 A.

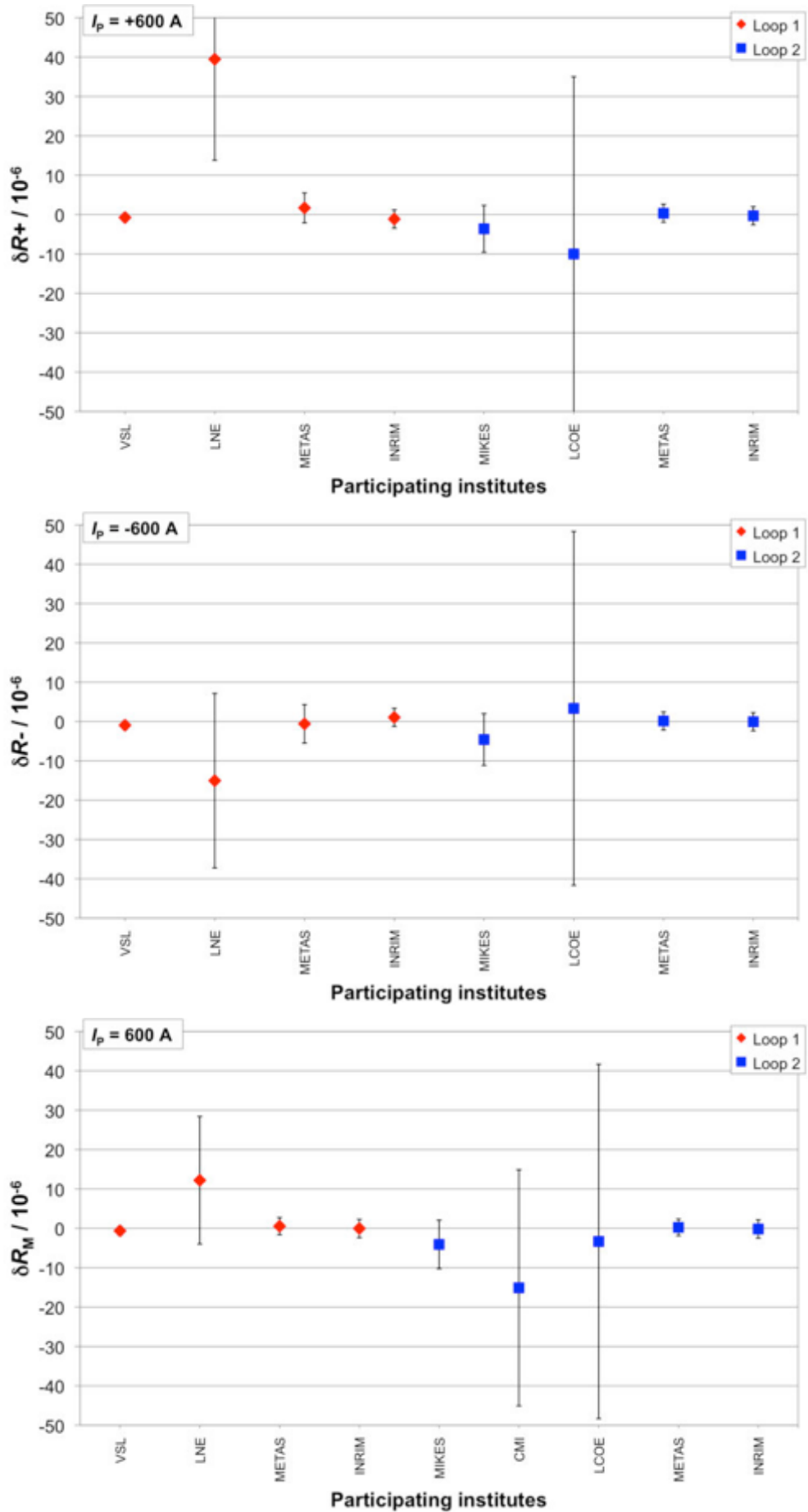

**Figure 5:** Relative errors of  $R_+$ ,  $R_-$  and  $R_M$  (with expanded uncertainties) with respect to the nominal value at 600 A.

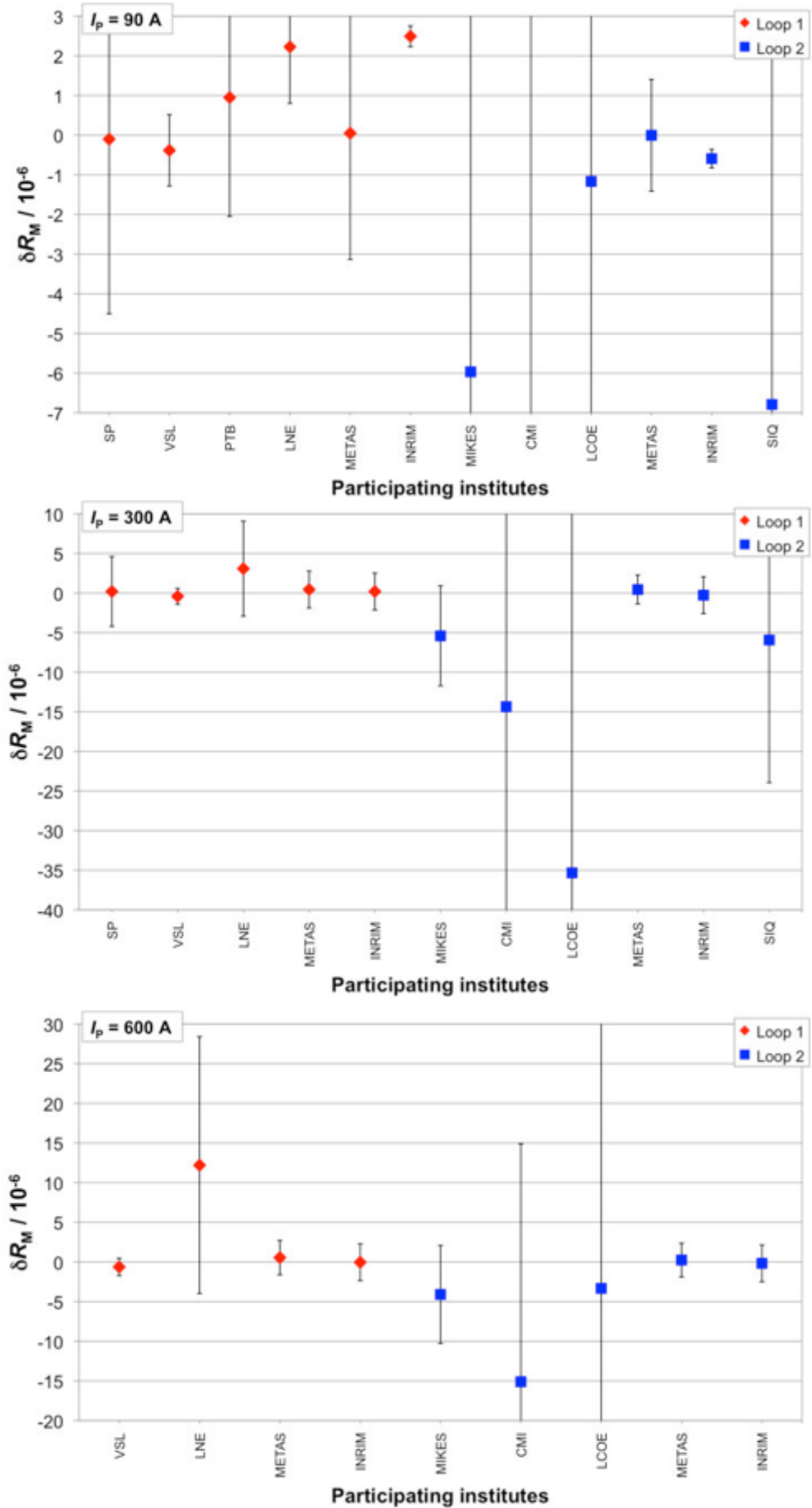

**Figure 6:** Relative errors of  $R_M$  (with expanded uncertainties) with respect to the nominal value at 90, 300 and 600 A (with zoomed y axes).

### 6.3 Normalization of the results

The comparison results are reported as relative error  $\delta R$  with respect to the nominal value of  $R$ . No other correction was applied on the comparison results.

### 6.4 Calculation of the reference value and its uncertainty

Not all comparison participants measured  $R+$  and  $R-$  independently (see Tab. 4), and not all (es. LNE) did not properly apply the measurand definition (1) of  $R+$  and  $R-$ , but all the participants provided a value of  $R_M$  (measured or calculated). For this reason,  $R+$  and  $R-$  results were reported but not used in this report, and the reference value was evaluated only for  $R_M$  for obtaining an overall estimation of capabilities of participants.

As the comparison had two loops with two travelling standards (contrary to the plan) there are two reference values,  $RV_1$  and  $RV_2$  for loop 1 and 2 respectively. They were evaluated, with their uncertainties, by a MATLAB routine using the model proposed in [3] for the case of measurements on two stable standards circulating in two loops, and where at least one Institute participates in both loops.

The  $RV_1$  and  $RV_2$  evaluation was done on the measurements of relative error  $\delta R_M$ , as given in (2), at the different value of  $I_P$ .

The Institutes participating in both loops were INRIM and METAS (pilots). The individual results of each institutes are correlated because measured (at different times) with the same measurement system<sup>(17)</sup>. Hence, the covariance matrix  $\Sigma$  associated to the comparison results can be written as

$$\Sigma = \Sigma_{ms} + \Sigma_{stb} \quad (3)$$

where  $\Sigma_{ms}$  is the covariance matrix of measurements results and  $\Sigma_{stb}$  is the diagonal covariance matrix of time stability of travelling standards.

$\Sigma_{ms}$ , defined as

$$\Sigma_{ms} = \begin{pmatrix} u_{SP}^2(\delta R_{M1}) & \cdots & 0 & 0 & \cdots & \cdots & 0 & 0 & 0 \\ \vdots & \ddots & \vdots & \vdots & \ddots & \vdots & \vdots & \vdots & \vdots \\ 0 & \cdots & u_{METAS}^2(\delta R_{M1}) & 0 & \cdots & u_{METAS}(\delta R_{M1}, \delta R_{M2}) & 0 & 0 & 0 \\ 0 & \cdots & 0 & u_{INRIM}^2(\delta R_{M1}) & \cdots & 0 & u_{INRIM}(\delta R_{M1}, \delta R_{M2}) & 0 & 0 \\ \vdots & \ddots & \vdots & \vdots & \ddots & \vdots & \vdots & \vdots & \vdots \\ 0 & \cdots & u_{METAS}(\delta R_{M1}, \delta R_{M2}) & 0 & \cdots & u_{METAS}^2(\delta R_{M2}) & 0 & 0 & 0 \\ \vdots & \cdots & 0 & u_{INRIM}(\delta R_{M1}, \delta R_{M2}) & \cdots & 0 & u_{INRIM}^2(\delta R_{M2}) & 0 & 0 \\ 0 & \cdots & 0 & 0 & \cdots & 0 & 0 & u_{SIQ}^2(\delta R_{M2}) & 0 \end{pmatrix} \quad (4)$$

where  $\delta R_{M1}$  and  $\delta R_{M2}$  are the  $\delta R_M$  values obtained by each participant in loop 1 and 2 respectively,  $u_{Inst}(\delta R_{M1})$  and  $u_{Inst}(\delta R_{M2})$  are the declared  $\delta R_M$  standard uncertainties, and  $u_{Inst}(\delta R_{M1}, \delta R_{M2})$  is the covariance of  $\delta R_M$  values obtained in the two loops by the same participant, and calculated as

$$u_{Inst}(\delta R_{M1}, \delta R_{M2}) = u_B(\delta R_{M1}) \cdot u_B(\delta R_{M2}) \quad (5)$$

where  $u_B(\delta R_{M1})$  and  $u_B(\delta R_{M2})$  (values shown in Tab. 5) are the sums of type B uncertainty contributions to  $u(\delta R_M)$  of each loop, assuming these contributions come from the measurement system as constant over time.

Notice that, because of correlation effects, the reference value uncertainty can become slightly smaller than the travelling standard uncertainty.

(17) The  $R_M$  value obtained by METAS in loop 2 with method 1 was considered (see Appendix A, B and C).

The time stability of both travelling standards was evaluated on a period of about 2 years, with uncertainty values given in Tab. 6.

The estimate reference values  $RV_1$  and  $RV_2$  and their relative uncertainty are given in Tab. 7.

$I_P$	$u_{\text{INRIM}}(\delta R_{M1}, \delta R_{M2})$ ( $10^{-6}$ )	$u_{\text{METAS}}(\delta R_{M1}, \delta R_{M2})$ ( $10^{-6}$ )
90 A	0.01	0.94
300 A	1.34	1.00
600 A	1.34	1.09

**Table 5:** Covariance of  $\delta R_M$  values obtained in the two loops by INRIM and METAS.

$I_P$	$u_{\text{stb}}(\delta R_{M1})$ ( $10^{-6}$ )	$u_{\text{stb}}(\delta R_{M2})$ ( $10^{-6}$ )
90 A	1.00	0.20
300 A	1.05	0.25
600 A	1.60	0.35

**Table 6:**  $\delta R_M$  standard uncertainty components due to time stability of travelling standards.

$I_P$	$RV_1$ ( $10^{-6}$ )	$u(RV_1)$ ( $10^{-6}$ )	$RV_2$ ( $10^{-6}$ )	$u(RV_2)$ ( $10^{-6}$ )
90 A	1.00	0.54	-0.48	0.21
300 A	0.02	0.73	-0.20	0.62
600 A	-0.05	1.05	-0.28	0.75

**Table 7:**  $RV_1$  and  $RV_2$  values with relative standard uncertainties<sup>(18, 19)</sup>.

(18) Some participants (SP, VSL, MIKES) considered an uncertainty contribution related to the error in positioning the current conductor(s), also called centering error. Only one participant (VSL) provided an explicit uncertainty associated to this effect, of  $1.7 \cdot 10^{-7}$ ; the others (SP, MIKES) included the contribution in a more generic Type A or type B reproducibility error. Some laboratories (PTB, METAS, INRIM, LCOE and LNE (private communication)) mentioned a self-centering bar, with negligible positioning error. One lab (SIQ) provided little information, and in principle they should revise their budget; however, it is expected that an additional contribution would not appreciably increase their stated uncertainties.

(19) During Loop 1, VSL noticed an unexpected dependence of the ratio error of METAS standard on the burden resistance, having a slope of  $-0.6 \cdot 10^{-6}/\text{ohm}$ . This effect was reported after the release of Draft A v. 1.0.

A correction of the values given by the participants for a reference burden, unfortunately, is not advisable because

a) there is no confirmation of VSL observation,

b) the reports provided by the participants do not always provide a complete information,

c) there are no measurement performed on INRIM standard to allow a correction.

The error dependence on burden has therefore been taken in consideration as a definitional uncertainty of the standards.

(follows)

## 6.5 Degrees of equivalence of the participating institutes

The degrees of equivalence for each comparison participant were obtained with the *METAS.Unclib* software via MATLAB [4], applying the model mentioned in previous paragraph, and described in [3].

The results are reported in Tab. 8, and their graphical representation for different  $I_P$  values are given in Fig. 7-9.

Institute	$I_P = 90$ A		$I_P = 300$ A		$I_P = 600$ A	
	DOE ( $10^{-6}$ )	$u(\text{DOE})$ ( $10^{-6}$ )	DOE ( $10^{-6}$ )	$u(\text{DOE})$ ( $10^{-6}$ )	DOE ( $10^{-6}$ )	$u(\text{DOE})$ ( $10^{-6}$ )
SP	-1.10	2.36	0.18	2.33	---	---
VSL	-1.38	0.95	-0.43	0.90	-0.58	1.32
PTB	-0.05	1.72	---	---	---	---
LNE	1.22	1.10	3.06	3.09	12.3	8.18
METAS	-0.95	1.80	0.43	1.39	0.60	1.62
INRIM	1.49	0.85	0.18	1.38	0.01	1.67
MIKES	-5.49	6.75	-5.20	3.11	-3.82	3.02
CMI	14.0	13.0	-14.2	13.5	-14.8	15.0
LCOE	-0.69	15.7	-35.1	24.7	-3.06	22.5
METAS	0.47	0.70	0.65	0.71	0.52	0.83
INRIM	-0.11	0.09	-0.07	1.01	0.11	0.95
SIQ	-6.31	10.5	-5.73	9.98	---	---

**Table 8:** DOE values with relative standard uncertainties.

Tab. N19 summarizes the ranges of the reported burden resistances by each participant. Assuming the same magnitude of burden dependence observed by VSL for both standards, the associated ratio uncertainty  $u_{\text{brd}}(\delta R_M)$  is also given. This uncertainty should be considered as a contribution to the reference values; it can be easily seen that this contribution can be safely considered negligible.

$I_P$	Loop 1				Loop 2			
	Burden range ( $\Omega$ )	Std. Dev. of burden range ( $\Omega$ )	$u_{\text{brd}}(\delta R_{M1})$ ( $10^{-6}$ )	Corrected $u(\text{RV}_1)$ ( $10^{-6}$ )	Burden range ( $\Omega$ )	Std. Dev. of burden range ( $\Omega$ )	$u_{\text{brd}}(\delta R_{M2})$ ( $10^{-6}$ )	Corrected $u(\text{RV}_2)$ ( $10^{-6}$ )
90 A	0.93	0.27	0.16	0.56	0.20	0.06	0.03	0.21
300 A	1.50	0.43	0.26	0.77	0.20	0.06	0.03	0.62
600 A	1.75	0.51	0.30	1.09	0.20	0.06	0.03	0.75

**Table N19:** Evaluation of the burden dependence effect on reference value uncertainty.

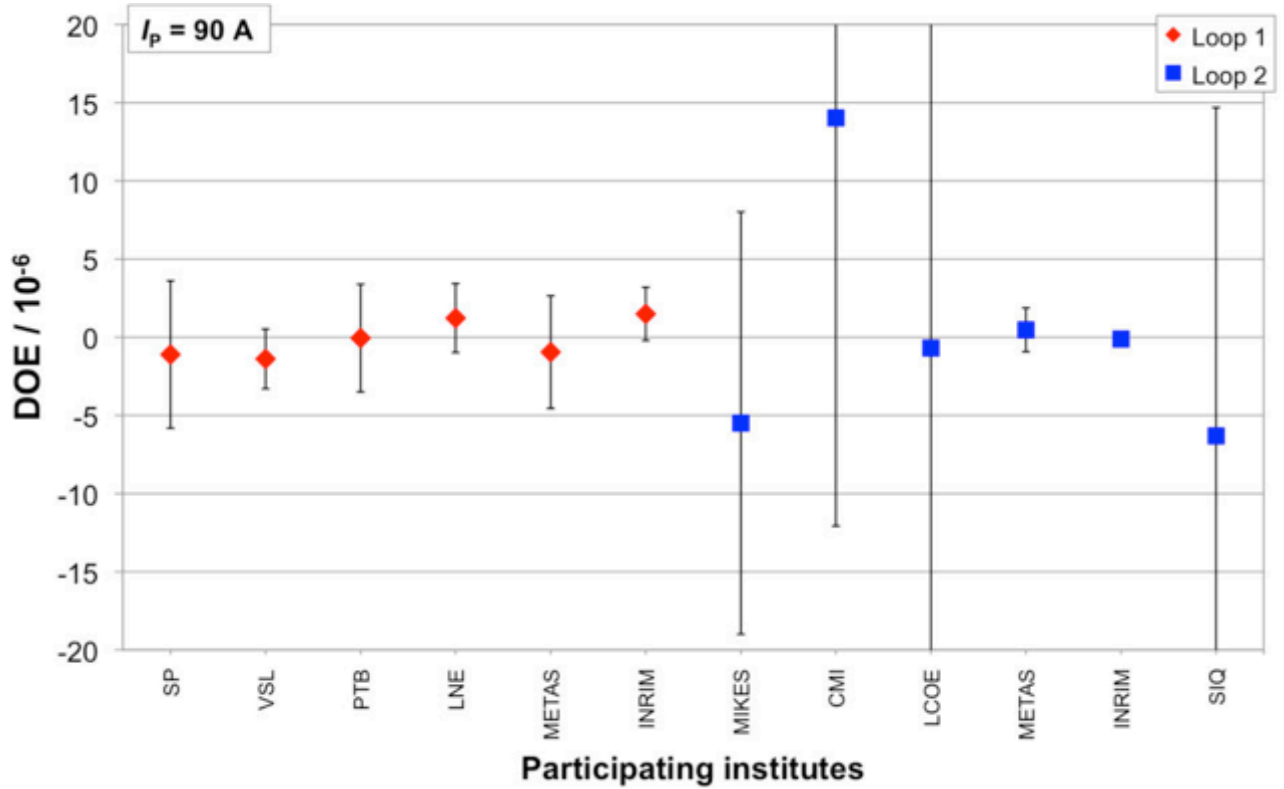

Figure 7: The degree of equivalence (with expanded uncertainty) at  $I_p = 90\text{ A}$ .

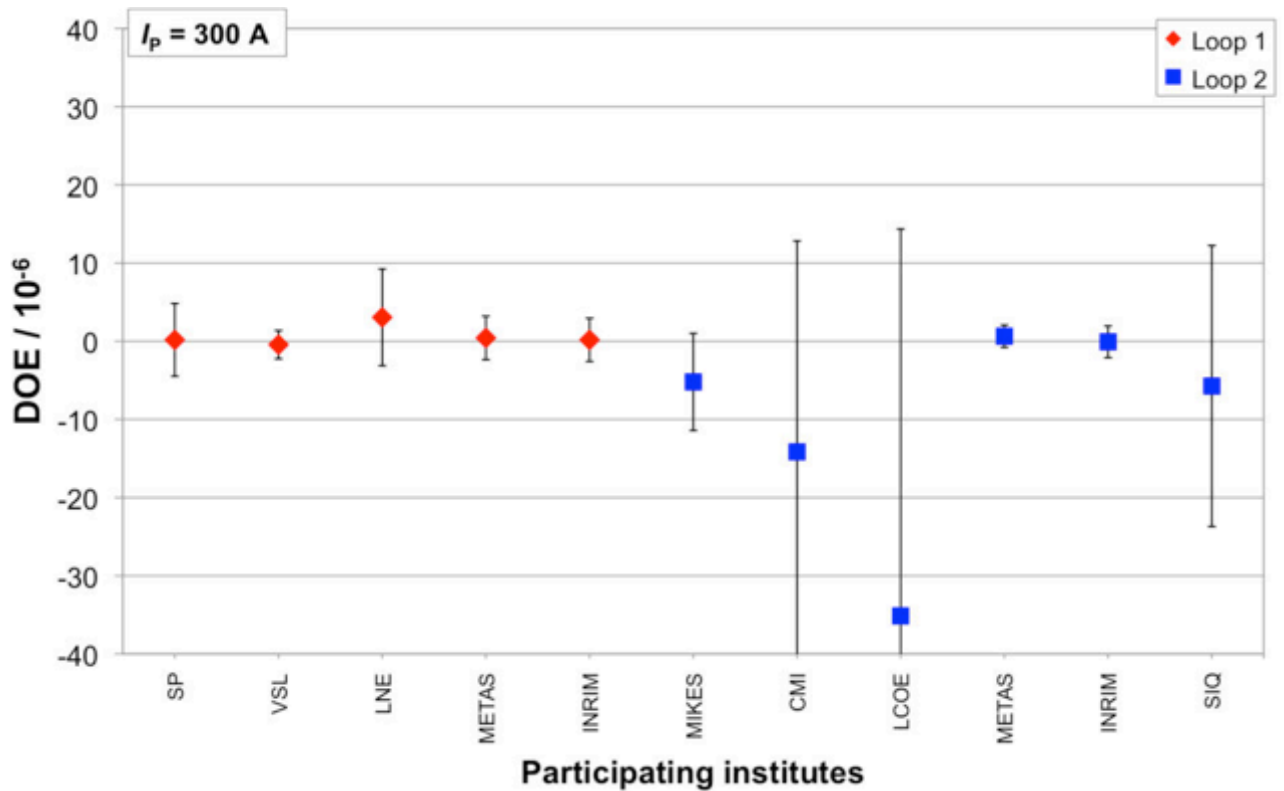
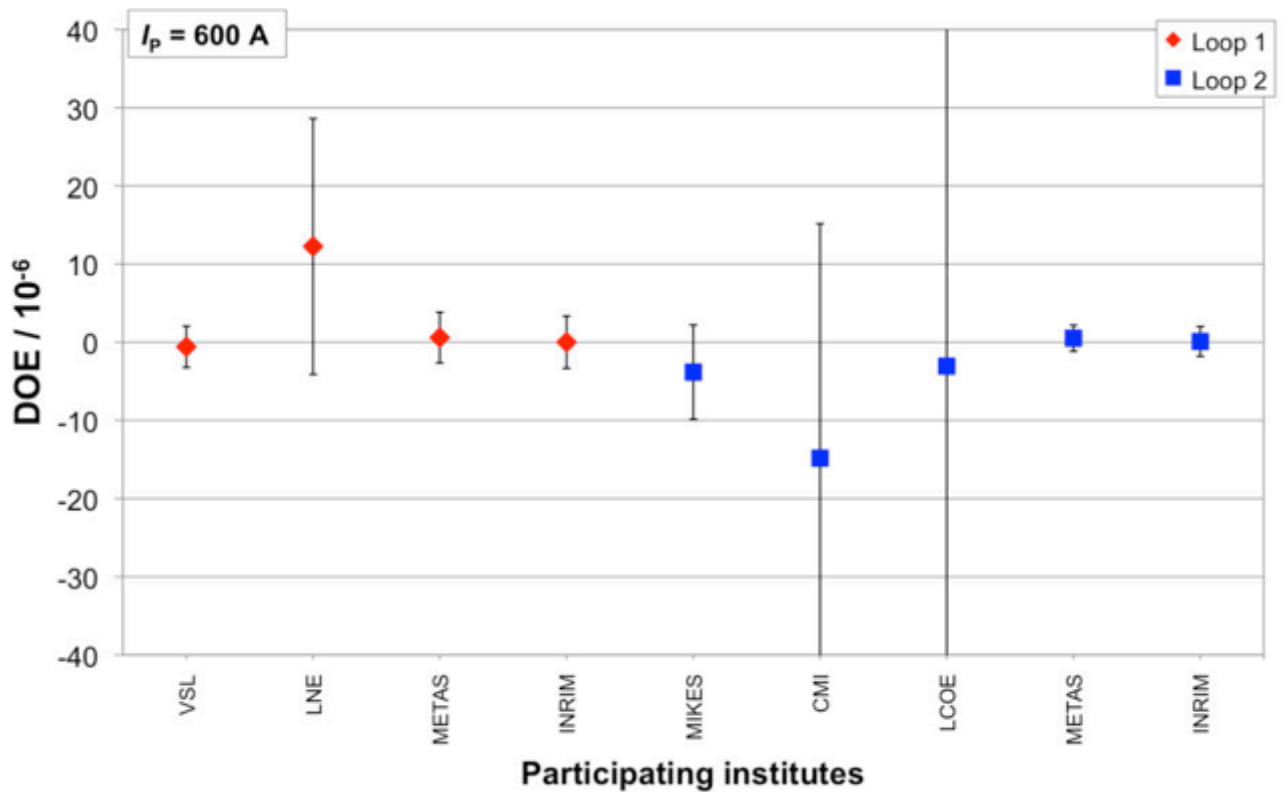

Figure 8: The degree of equivalence (with expanded uncertainty) at  $I_p = 300\text{ A}$ .



**Figure 9:** The degree of equivalence (with expanded uncertainty) at  $I_p = 600$  A.

## 6.6 Link to the CCEM KC and degrees of equivalence

N/A.

## 7. Changes with respect to draft A version 2.0

### 7.1 Changes requested by the participants

Institute	Change requested	Draft A section
LNE	Adding information about the centering of bus-bar.	6.4 (page 16, note 18)

**Table 9:** Changes with respect to draft A version 2.0 (13.12.18).

### 7.2 Changes and corrections by the pilot laboratory

Pilot	Change requested	Draft A section
INRIM	Updating of references.	9 (page 20)

**Table 10:** Changes with respect to draft A version 2.0 (13.12.18).

## 8. Summary and conclusions

The primary scope of the comparison is the validation of NMI CMCs for quantities related to dc high currents.

The measurand is the current ratio of a direct-current current transformer, of nominal value  $R = 1:1500$ , to be measured at primary currents of 90 A (mandatory), 300 A and 600 A (optional). The measurement results can be stated for positive and negative currents, and/or as an average of the ratios obtained with both current polarities.

There were twelve participants (two pilot laboratories included), eleven of them measured the travelling standard, and ten provided results. Two participants withdrew due to technical problems. No participant deviated from the comparison protocol; all reported the significant information required.

Originally the comparison, organized into two loops, provided for measurement of a single travelling standard; however, because of a suspected malfunctioning at the beginning of 2<sup>nd</sup> loop, the pilot laboratories decided to replace the standard with another of the same model. Consequently, during the loop 1 the participants measured a different standard than those participating in loop 2. The pilot laboratories measured both standards, and therefore made possible the linking of measurement results of the participants of loop 1 with those of loop 2. The circulation of the standards started in December 2012 and ended in June 2015.

Concerning the measurement results, the travelling standard instability of loop 1 represented a relevant contribution to the DOE uncertainty, which is significantly larger than the measurement uncertainty declared by some participants. In particular, the validation of INRIM, METAS and VSL results were limited by this effect.

Each laboratory checked the results of the comparison on their CMC claims.

## 9. References

- [1] “CCEM Guidelines for Planning, Organizing, Conducting and Reporting Key, Supplementary and Pilot Comparisons” and annexes, 2007 and 2017.
- [2] Cox M. G., “The evaluation of key comparison data”, *Metrologia*, 2002, 39, 589-595.
- [3] Nielsen L., “Evaluation of measurement intercomparisons by the method of least squares”, DFM-99-R39, 3208 LN, 2000, 1-12.
- [4] Zeier M., Hoffmann J., Wollensack M., “*Metas.UncLib* – a measurement uncertainty calculator for advanced problems”, *Metrologia*, 2012, 49, 809-815.

**Supplementary Comparison EURAMET.EM-35  
Comparison of High-Current Ratio Standard**

**FINAL REPORT – ANNEX A  
Measurement results reported by the participants**

C. Cassiago<sup>a</sup> and A. Mortara<sup>b</sup>

a Istituto Nazionale di Ricerca Metrologica, INRIM  
Strada delle Cacce 91, 10135 Turin, Italy

b Federal Institute of Metrology, METAS  
Lindenweg 50, 3003 Bern-Wabern, Switzerland

## Table of Contents

1. Introduction .....	3
2. CMI – Czech Metrology Institute (Czech Republic) .....	3
2.1 Measurement results .....	3
3. INRIM – Istituto Nazionale di Ricerca Metrologica (Italy).....	5
3.1 Measurement results .....	5
4. LCOE – Laboratorio Central Oficial de Electrotecnia (Spain) .....	6
4.1 Results .....	6
4.2 Excel tables .....	7
5. LNE – Laboratoire national de métrologie et d’essais (France) .....	8
5.1 Results .....	8
5.2 Excel tables .....	8
6. METAS – Federal Institute of Metrology METAS (Switzerland).....	10
6.1 Measurement results .....	10
6.1 Excel tables .....	11
7. MIKES – Centre for Metrology and Accreditation (Finland).....	12
7.1 Calibration results .....	12
7.2 Excel tables .....	13
8. PTB – Physikalisch-Technische Bundesanstalt (Germany).....	15
8.1 Results and environmental conditions .....	15
8.2 Appendix: detailed results.....	15
8.3 Excel tables .....	15
9. SIQ – Slovenian Institute of Quality and Metrology (Slovenia).....	16
9.1 Results .....	16
9.2 Excel tables .....	16
10. SP – SP Technical Research Institute of Sweden (Sweden) .....	17
10.1 Results .....	17
10.2 Excel tables .....	17
11. VSL – VSL Dutch Metrology Institute (Netherlands).....	18
11.1 Measurement results .....	18
11.2 Excel tables .....	18

## 1. Introduction

This is the list of measurement results obtained by each participant (sorted alphabetically by participant acronym), extracted from their comparison reports, together the Excel tables sent to comparison coordinator.

## 2. CMI – Czech Metrology Institute (Czech Republic)

### 2.1 Measurement results

The measured primary current was determined according to

$$I_p(+)=\frac{1}{N}\sum_{i=1}^N\frac{U_{RN1i}(+)}{R_{N1}}, \quad I_p(-)=\frac{1}{N}\sum_{i=1}^N\frac{U_{RN1i}(-)}{R_{N1}}, \quad (2)$$

where  $N$  is number of measurements,

$U_{RN1i}$  is the voltage  $U_{RN1}$  corresponding to  $i^{\text{th}}$  measurement (V),

$R_{N1}$  is value of the standard resistor ( $\Omega$ ).

The measured secondary current  $I_s$  was determined according to

$$I_s(+)=\frac{1}{N}\sum_{i=1}^N\frac{U_{RN2i}(+)}{R_{N2}}, \quad I_s(-)=\frac{1}{N}\sum_{i=1}^N\frac{U_{RN2i}(-)}{R_{N2}}, \quad (3)$$

where  $N$  is number of measurements,

$U_{RN1i}$  is the voltage  $U_{RN1}$  corresponding to  $i^{\text{th}}$  measurement (V),

$R_{N2}$  is value of the standard resistor ( $\Omega$ ).

Current ratios  $R(+)$  a  $R(-)$  were calculated according to

$$R(+)=\frac{I_s(+)}{I_p(+)}, \quad R(-)=\frac{I_s(-)}{I_p(-)}. \quad (4)$$

The resulting current ratio  $R$  is given as

$$R=\frac{R(+)+R(-)}{2}=\frac{\frac{I_s(+)}{I_p(+)}+\frac{I_s(-)}{I_p(-)}}{2}. \quad (5)$$

*Note:*

Whereas in each set of measurement the voltage  $U_{RN20}$ , corresponding to the current  $I_{\text{off}}$  did not vary it may be according to (1) assumed that an influence of the current  $I_{\text{off}}$  is excluded when making averaging according to (5).

Date	Primary current (A)	$u(I_p)$ (A)	Secondary current (A)	$u(I_s)$ (A)	Temperature ( $^{\circ}\text{C}$ )	$u(T)$ ( $^{\circ}\text{C}$ )	Humidity (%)	$u(H)$ (%)	Power supply (V)	$u(PS)$ (V)	Power supply variation (%)	Measurement result (Ratio value)	Combined standard uncertainty (Ratio uncertainty)	Expanded uncert. U
III/14	89,97628	0,00066	0,0599850	6 E-7	23	0,3	52	1,5	$\pm 15$	0,1	0,2	6,666757E-04	0,000087 E-04	0,00017 E-04
III/14	302,2762	0,0023	0,2015146	1,5 E-7	23,4	0,3	55	1,5	$\pm 15$	0,1	0,2	6,666571E-04	0,000088 E-04	0,00018 E-04
III/14	598,7166	0,0047	0,3991384	2,8 E-6	23,2	0,3	53	1,5	$\pm 15$	0,1	0,2	6,666566 E-04	0,000098 E-04	0,00020 E-04

Table 1. Measuring results

*Note:*

Uncertainties of the primary and secondary currents  $u(I_p)$  and  $u(I_s)$  in the table 1 are given only by the type B uncertainty component. The combined uncertainty is given by the result of the ratio  $R$ .

### 3. INRIM – Istituto Nazionale di Ricerca Metrologica (Italy)

#### 3.1 Measurement results

The ratio  $R$  of both DCCTs employed in the comparison was measured for positive and negative  $I_P$ , and the average value  $R_M$  was calculated as

$$R_M = \frac{(R+) + (R-)}{2} \tag{7}$$

where  $R+ = R(+I_P)$  and  $R- = R(-I_P)$ .

The results are given in Tab. 2 where:

- $R$  is absolute ratio value,
- $\delta R$  is relative error respect the nominal ratio value  $R_{nom} = 1/1500 \approx 6.6666667 \times 10^{-4}$ ,
- $T_B$  is mean temperature of bus bar at about 30 cm from the DCCTs,
- $T_D$  is mean temperature of DCCT.

The analysis of DCCT temperature behaviour involved a larger set of measurements, and it revealed no specific trend of  $R$  for  $I_P = 90$  A, while for  $I_P = 300$  and 600 A it showed an offset drift, but it did not affect  $R$  significantly, so no correction for temperature effects was applied.

The geometrical position of DCCT embedded electronic respect the  $I_P$  winding was also considered, but no significative influence was observed. However all measurement was performed holding the DCCTs always in the same position, with the electronics outside the  $I_P$  winding.

The environmental conditions during the measurements are reported in Tab. 1, where  $T_A$  and  $H_A$  are respectively the mean ambient temperature and humidity.

Date	$I_P$ (A)	$T_A$ (°C)	$u(T_A)$ (°C)	$H_A$ (%)	$u(H_A)$ (%)
14 Jun 2013	90	23.33	0.01	51.1	1.4
17 Jun 2013	300	23.80	0.01	58.2	1.4
17 Jun 2013	600	23.62	0.01	53.2	1.4
06 Mar 2015	90	23.68	0.01	40.8	1.4
19 Mar 2015	300	23.32	0.01	46.4	1.4
19 Mar 2015	600	23.75	0.01	40.0	1.4

Tab. 1 – Environmental conditions

Loop	DCCT	Date	$I_P$ (A)	$u(I_P)$ (A)	$T_B$ (°C)	$u(T_B)$ (°C)	$T_D$ (°C)	$u(T_D)$ (°C)	$R$ (10 <sup>-4</sup> )	$u(R)$ (10 <sup>-1</sup> )	$U(R)$ (10 <sup>-6</sup> )	$k$	$\delta R$ (10 <sup>-6</sup> )	$u(\delta R)$ (10 <sup>-7</sup> )	$U(\delta R)$ (10 <sup>-7</sup> )
1	METAS	14 Jun 2013	+90	0.09	24.59	0.01	33.20	0.01	6.6666835	8.4	1.7	1.97	2.53	1.3	2.5
			-90	0.09	24.72	0.01	33.34	0.01	6.6666831	11	2.2	2.01	2.46	1.6	3.2
			+300	0.3	25.22	0.01	34.28	0.01	6.6666643	77	1.8	2.00	2.49	1.3	2.6
			-300	0.3	25.47	0.01	34.40	0.01	6.6666718	77	1.5	1.98	0.77	12	23
			+600	0.6	27.98	0.01	34.75	0.01	6.6666592	77	15	1.98	-1.13	12	23
			-600	0.6	28.78	0.01	34.94	0.01	6.6666737	77	15	1.98	1.05	12	23
2	INRIM	06 Mar 2015	+90	0.09	26.40	0.01	32.64	0.01	6.6666615	8.0	1.6	1.97	-0.77	1.2	2.4
			-90	0.09	26.34	0.01	32.66	0.01	6.6666639	7.8	1.5	1.97	-0.41	1.2	2.3
			+300	0.3	25.64	0.01	33.27	0.01	6.6666633	77	15	1.98	-0.50	12	23
			-300	0.3	25.86	0.01	33.40	0.01	6.6666664	77	15	1.98	-0.04	12	23
			+600	0.6	31.77	0.01	34.45	0.01	6.6666647	77	15	1.98	-0.29	12	23
			-600	0.6	32.29	0.01	34.55	0.01	6.6666664	77	15	1.98	-0.05	12	23
								$R_M$	6.6666655	77	15	2.00	-0.17	12	23

Tab. 2 – Measurement results

## 4. LCOE – Laboratorio Central Oficial de Electrotecnia (Spain)

### 4.1 Results

Results are summarized in official certificate number 201406600701

#### 1. Characteristics of the instrument under calibration

Mark: LEM  
Model: IT 600-S  
Serial number: 9112230053

Nominal primary current: 600 A  
Nominal primary to secondary current ratio: 1/1500  
Power supply: 0 V, and  $\pm 15$  V

#### 2. Calibration procedures used

The calibration has been performed following the procedures PS6.11, PS6.12 and PS6.56 of L.C.O.E.

#### 3. Standard instruments used in the calibration

The calibration has been performed using the standards VI1MD01, VI1SC01, VI1MD02, VI1SC07, VI1SC09 and VI1R08 of L.C.O.E.

#### 4. Calibration uncertainty

The expanded measurement uncertainty indicated in the results tables has been obtained multiplying the typical uncertainty by the coverage factor  $k = 2$ , that for a normal probability distribution corresponds to a probability around 95%. The typical uncertainty has been determined following the document EA 4 / 02.

#### 5. Calibration and environmental conditions

The instrument under calibration has been inside the laboratory for at least two hours before beginning the calibration. By request of the applicant the calibration has been performed in the measuring points indicated in the results tables. Calibration has been carried out in the laboratory L9 at the ambient temperature of  $23^{\circ}\text{C} \pm 1^{\circ}\text{C}$ , and relative humidity lower than  $50\% \pm 10\%$ .

#### 6. Calibration results

Calibration results are summarized in the calibration tables.

#### 7. Labelling or sealing

A calibration label has been stucked on the instrument under calibration.

#### 8. Measurement traceability

Measurement traceability is referred to our reference standards periodically calibrated in national laboratories participating in intercomparisons accepted by the BIPM or in laboratories accredited by ENAC or by other accreditation bodies recognized by ENAC.

#### 9. Reception date

10/06/2014.

Calibration DC current, 90 A

Primary current	Secondary current	Temperature			Humidity			Power supply		u (PS)	Power supply variation ±	Measurement result (Ratio value)	Combined standard uncertainty (Ratio uncertainty)	Coverage factor k (95%)
		Mean value	Range of variation ±	u(T)	Mean value	Range of variation ±	u(H)	+ 15 V	- 15 V					
90 A	60 mA	22,90 °C	0,30 °C	0,50 °C	40,50 %	0,50 %	3,0 %	15,135 V	-15,120 V	0,03 V	0,015 V	0,0006666660	1,0E-08	2
-90 A	-60 mA	23,30 °C	0,10 °C	0,50 °C	40,35 %	0,45 %	3,0 %	15,135 V	-15,120 V	0,03 V	0,015 V	0,0006666658	1,0E-08	2
±90 A	±60 mA	23,10 °C	0,30 °C	0,50 °C	40,43 %	0,50 %	3,0 %	15,135 V	-15,120 V	0,03 V	0,015 V	0,0006666659	1,0E-08	2

Calibration DC current, 300 A

Primary current	Secondary current	Temperature			Humidity			Power supply		u (PS)	Power supply variation ±	Measurement result (Ratio value)	Combined standard uncertainty (Ratio uncertainty)	Coverage factor k (95%)
		Mean value	Range of variation ±	u(T)	Mean value	Range of variation ±	u(H)	+ 15 V	- 15 V					
300 A	200 mA	22,50 °C	0,00 °C	0,50 °C	40,40 %	0,10 %	3,0 %	15,115 V	-15,100 V	0,03 V	0,015 V	0,0006666427	1,7E-08	2
-300 A	-200 mA	22,55 °C	0,05 °C	0,50 °C	40,20 %	0,00 %	3,0 %	15,115 V	-15,100 V	0,03 V	0,015 V	0,0006666436	1,7E-08	2
±300 A	±200 mA	22,53 °C	0,05 °C	0,50 °C	40,30 %	0,10 %	3,0 %	15,115 V	-15,100 V	0,03 V	0,015 V	0,0006666431	1,7E-08	2

Calibration DC current, 600 A

Primary current	Secondary current	Temperature			Humidity			Power supply		U(PS)	Power supply variation ±	Measurement result (Ratio value)	Combined standard uncertainty (Ratio uncertainty)	Coverage factor k (95%)
		Mean value	Range of variation ±	u(T)	Mean value	Range of variation ±	u(H)	+ 15 V	- 15 V					
600 A	400 mA	22,80 °C	0,30 °C	0,50 °C	40,55 %	0,55 %	3,0 %	15,130 V	-15,095 V	0,03 V	0,015 V	0,0006666600	1,5E-08	2
-600 A	-400 mA	22,60 °C	0,10 °C	0,50 °C	40,25 %	0,55 %	3,0 %	15,130 V	-15,095 V	0,03 V	0,015 V	0,0006666689	1,5E-08	2
±600 A	±400 mA	22,70 °C	0,30 °C	0,50 °C	40,40 %	0,55 %	3,0 %	15,130 V	-15,095 V	0,03 V	0,015 V	0,0006666644	1,5E-08	2

## 4.2 Excel tables

Laboratory: LCOE

Standard: LEM IT-600 S  
sn: 8100088322

Detailed Measurement Results

Nominal value primary current = 90 A and secondary current = 60 mA																
Date	Primary current (A)	u(I <sub>p</sub> ) (A)	Secondary current (A)	u(I <sub>s</sub> ) (A)	Temperature (°C)	u(T) <sup>rel</sup> (°C)	Humidity (%)	u(H) <sup>rel</sup> (%)	Power supply +15 V (V)	-15 V (V)	u(PS) <sup>rel</sup> (V)	Power supply variation (%)	Measurement result (Ratio value) <sup>rel</sup>	Extended standard uncertainty U (Ratio uncertainty)	Coverage factor k (95%)	
01-07-14	90	--	0,06	--	22,90	0,5	40,50	3	15,14	-15,12	0,03	0,1	R+	6.66660E-04	2,1E-08	2
01-07-14	90	--	0,06	--	23,30	0,5	40,35	3	15,14	-15,12	0,03	0,1	R-	6.66658E-04	2,1E-08	2
01-07-14	90	--	0,06	--	23,10	0,5	40,43	3	15,14	-15,12	0,03	0,1	R <sub>u</sub>	6.66659E-04	2,1E-08	2

Nominal value primary current = 300 A and secondary current = 200 mA																
Date	Primary current (A)	u(I <sub>p</sub> ) (A)	Secondary current (A)	u(I <sub>s</sub> ) (A)	Temperature (°C)	u(T) <sup>rel</sup> (°C)	Humidity (%)	u(H) <sup>rel</sup> (%)	Power supply +15 V (V)	-15 V (V)	u(PS) <sup>rel</sup> (V)	Power supply variation (%)	Measurement result (Ratio value) <sup>rel</sup>	Extended standard uncertainty U (Ratio uncertainty)	Coverage factor k (95%)	
01-07-14	300	--	0,2	--	22,50	0,5	40,40	3	15,12	-15,10	0,03	0,1	R+	6.666427E-04	3,3E-08	2
01-07-14	300	--	0,2	--	22,55	0,5	40,20	3	15,12	-15,10	0,03	0,1	R-	6.666436E-04	3,3E-08	2
01-07-14	300	--	0,2	--	22,53	0,5	40,30	3	15,12	-15,10	0,03	0,1	R <sub>u</sub>	6.666431E-04	3,3E-08	2

Nominal value primary current = 600 A and secondary current = 400 mA																
Date	Primary current (A)	u(I <sub>p</sub> ) (A)	Secondary current (A)	u(I <sub>s</sub> ) (A)	Temperature (°C)	u(T) <sup>rel</sup> (°C)	Humidity (%)	u(H) <sup>rel</sup> (%)	Power supply +15 V (V)	-15 V (V)	u(PS) <sup>rel</sup> (V)	Power supply variation (%)	Measurement result (Ratio value) <sup>rel</sup>	Extended standard uncertainty U (Ratio uncertainty)	Coverage factor k (95%)	
01-07-14	600	--	0,4	--	22,80	0,5	40,55	3	15,13	-15,10	0,03	0,1	R+	6.66600E-04	3,0E-08	2
01-07-14	600	--	0,4	--	22,60	0,5	40,25	3	15,13	-15,10	0,03	0,1	R-	6.66689E-04	3,0E-08	2
01-07-14	600	--	0,4	--	22,70	0,5	40,40	3	15,13	-15,10	0,03	0,1	R <sub>u</sub>	6.66644E-04	3,0E-08	2

u(I<sub>p</sub>) and u(I<sub>s</sub>) are not calculated because the calibration procedure and the model function used is not intended to determine I<sub>p</sub> and I<sub>s</sub>, but the ratio value, R.

## 5. LNE – Laboratoire national de métrologie et d’essais (France)

### 5.1 Results

#### Ambient conditions

Temperature of the measurement room (temperature regulated) :

Primary current 90 A:  $(23.0 \pm 0.5)^\circ\text{C}$

Primary current 300 A and 600 A:  $(23.0 \pm 1.5)^\circ\text{C}$

Temperature LEM (measured on the primary current bus bar, close to the measuring head):

Primary current 90 A: Mean value: 24.4 °C

Uncertainty: 0.5 °C

Range of variation: 23.8 °C – 25.5 °C

Primary current 300A: Mean value: 34.0 °C

Uncertainty: 0.5 °C

Range of variation: 33.3 °C – 35.0 °C

Primary current 600A: Mean value: 59.1 °C

Uncertainty: 0.5 °C

Range of variation: 57.3 °C – 62.0 °C

Humidity (regulated room):

For all measurements:  $(45 \pm 5)\%$

Power supply level:

For all measurements: Mean value: 15.01 V

Uncertainty: 0.02 V

PS variation: 0.01 %

### 5.2 Excel tables

Measurement results : mean values

Date	Primary current (A)	$u(I_p)$ (A)	Temperature LEM (°C)	$u(T)$ (°C)	Measurement result (Ratio value)	$u$ - A (Ratio type A uncertainty)	Combined standard (Ratio uncertainty)	Extended standard uncertainty $U$ (Ratio uncertainty)	Coverage factor $k$ (95%)
12-04-13	90.001	0.075	24.4	0.5	R+	6.6665688E-04	1.2E-09	1.3E-09	2
12-04-13	-90.001	0.075	24.4	0.5	R-	6.6667972E-04	1.6E-09	1.7E-09	2
12-04-13					RM	6.6666815E-04	3.5E-10	4.7E-10	2
24-04-13	300.9	1.3	34.0	0.5	R+	6.666490E-04	1.7E-09	3.2E-09	2
24-04-13	299.2	5.3	34.0	0.5	R-	6.6664234E-04	7.3E-10	2.5E-09	2
24-04-13					RM	6.666672E-04	8.5E-10	2.0E-09	2
24-04-13	600.2	1.2	59.1	0.5	R+	6.6669297E-04	3.4E-09	8.5E-09	2
24-04-13	604.5	4.3	59.1	0.5	R-	6.666564E-04	3.3E-10	7.4E-09	2
24-04-13					RM	6.6667492E-04	1.6E-09	5.4E-09	2

Nominal value primary current = 90 A and secondary current = 60 mA

Date	Primary current (A)	$u(I_p)$ (A)	Secondary current (A)	$u(I_s)$ (A)	Temperature (°C)	$u(T)$ (°C)	Humidity (%)	$u(H)$ (%)	Temperature LEM (°C)	$u(T)$ (°C)	Power supply (V)		$u(PS)$ (V)	Power supply variation (%)	Measurement result (Ratio value) <sup>III</sup>	Extended standard uncertainty $U$ (Ratio uncertainty)	Coverage factor $k$ (95%)	
											+15 V	-15 V						
16-04-13	90.001	0.075	0.06		22.8	0.5	45	5	23.8	0.5	15.01	-15.01	0.02	0.01	R+	6.6665714E-04	8.9E-10	2
16-04-13	-90.001	0.075	0.06		22.8	0.5	45	5	23.8	0.5	15.01	-15.01	0.02	0.01	R-	6.6667809E-04	8.9E-10	2
16-04-13															RM	6.666761E-04	6.3E-10	2
15-04-13	90.001	0.075	0.06		22.9	0.5	45	5	24.0	0.5	15.01	-15.01	0.02	0.01	R+	6.6665454E-04	8.9E-10	2
15-04-13	-90.001	0.075	0.06		22.9	0.5	45	5	24.0	0.5	15.01	-15.01	0.02	0.01	R-	6.6668228E-04	8.9E-10	2
15-04-13															RM	6.666841E-04	6.3E-10	2
12-04-13	90.001	0.075	0.06		22.9	0.5	45	5	24.0	0.5	15.01	-15.01	0.02	0.01	R+	6.6665714E-04	9.0E-10	2
12-04-13	-90.001	0.075	0.06		22.9	0.5	45	5	24.0	0.5	15.01	-15.01	0.02	0.01	R-	6.6667945E-04	9.0E-10	2
12-04-13															RM	6.666843E-04	6.3E-10	2
11-04-13	90.001	0.075	0.06		23.2	0.5	45	5	24.5	0.5	15.01	-15.01	0.02	0.01	R+	6.6665729E-04	8.9E-10	2
11-04-13	-90.001	0.075	0.06		23.2	0.5	45	5	24.5	0.5	15.01	-15.01	0.02	0.01	R-	6.6668228E-04	9.0E-10	2
11-04-13															RM	6.666797E-04	6.3E-10	2
10-04-13	90.001	0.075	0.06		23.2	0.5	45	5	25.5	0.5	15.01	-15.01	0.02	0.01	R+	6.6665654E-04	8.9E-10	2
10-04-13	-90.001	0.075	0.06		23.2	0.5	45	5	25.5	0.5	15.01	-15.01	0.02	0.01	R-	6.6668013E-04	8.9E-10	2
10-04-13															RM	6.666834E-04	6.3E-10	2

Nominal value primary current = 90 A and secondary current = 60 mA

Date	Primary current (A)	$u(I_p)$ (A)	Primary resistance (Ω)	$u(Rp)$ (Ω)	Secondary resistance (Ω)	$u(Rs)$ (Ω)	Voltage difference (V)	$u(\Delta U)$ (V)	Temperature LEM (°C)	$u(T)$ (°C)	Power supply (V)		$u(PS)$ (V)	Power supply variation (%)	Measurement result (Ratio value) <sup>III</sup>	Extended standard uncertainty $U$ (Ratio uncertainty)	Coverage factor $k$ (95%)	
											+15 V	-15 V						
16-04-13	90.001	0.075	0.001287234	1.5E-09	1.93092989	2.6E-07	3.06E-06	6.6E-08	23.8	0.5	15.01	-15.01	0.02	0.01	R+	6.6665714E-04	8.9E-10	2
16-04-13	-90.001	0.075	0.001287234	1.5E-09	1.93092989	2.6E-07	6.70E-06	6.7E-08	23.8	0.5	15.01	-15.01	0.02	0.01	R-	6.6667809E-04	8.9E-10	2
16-04-13															RM	6.666761E-04	6.3E-10	2
15-04-13	90.001	0.075	0.001287234	1.5E-09	1.93093015	2.6E-07	2.61E-06	6.6E-08	24.0	0.5	15.01	-15.01	0.02	0.01	R+	6.6665454E-04	8.9E-10	2
15-04-13	-90.001	0.075	0.001287234	1.5E-09	1.93093015	2.6E-07	7.43E-06	6.7E-08	24.0	0.5	15.01	-15.01	0.02	0.01	R-	6.6668228E-04	8.9E-10	2
15-04-13															RM	6.666841E-04	6.3E-10	2
12-04-13	90.001	0.075	0.001287235	1.6E-09	1.93092936	2.6E-07	2.98E-06	6.6E-08	24.0	0.5	15.01	-15.01	0.02	0.01	R+	6.6665714E-04	9.0E-10	2
12-04-13	-90.001	0.075	0.001287235	1.6E-09	1.93092936	2.6E-07	6.81E-06	6.7E-08	24.0	0.5	15.01	-15.01	0.02	0.01	R-	6.6667945E-04	9.0E-10	2
12-04-13															RM	6.666843E-04	6.3E-10	2
11-04-13	90.001	0.075	0.001287236	1.6E-09	1.93092915	2.6E-07	2.88E-06	6.6E-08	24.5	0.5	15.01	-15.01	0.02	0.01	R+	6.6665729E-04	8.9E-10	2
11-04-13	-90.001	0.075	0.001287236	1.6E-09	1.93092915	2.6E-07	6.59E-06	6.7E-08	24.5	0.5	15.01	-15.01	0.02	0.01	R-	6.6668228E-04	9.0E-10	2
11-04-13															RM	6.666797E-04	6.3E-10	2
10-04-13	90.001	0.075	0.001287236	1.5E-09	1.930928505	2.6E-07	2.67E-06	6.6E-08	25.5	0.5	15.01	-15.01	0.02	0.01	R+	6.6665654E-04	8.9E-10	2
10-04-13	-90.001	0.075	0.001287236	1.5E-09	1.930928505	2.6E-07	6.77E-06	6.7E-08	25.5	0.5	15.01	-15.01	0.02	0.01	R-	6.6668013E-04	8.9E-10	2
10-04-13															RM	6.666834E-04	6.3E-10	2

Nominal value primary current = 300 A and secondary current = 200 mA																		
Date	Primary current (A)	$u(I_1)$ (A)	Secondary current (A)	$u(I_2)$ (A)	Temperature (°C)	$u(T)^{III}$ (°C)	Humidity (%)	$u(H)^{III}$ (%)	Temperature LEM		Power supply		$u(PS)^{III}$ (V)	Power supply variation (%)	Measurement result (Ratio value) <sup>III</sup>	Extended standard uncertainty U (Ratio uncertainty)	Coverage factor k (95%)	
									(°C)	(°C)	+15 V (V)	-15 V (V)						
23-04-13	300.3	1.3			23.1	1.5	45	5	35.02	0.5	15.01	-15.01	0.02	0.01	R+	6.6699E-04	5.5E-09	2
23-04-13	300.4	5.3			23.1	1.5	45	5	35.02	0.5	15.01	-15.01	0.02	0.01	R-	6.6642E-04	4.8E-09	2
23-04-13															RM	6.6669E-04	3.6E-09	2
24-04-13	300.9	1.3			23.79	1.5	45	5	33.31	0.5	15.01	-15.01	0.02	0.01	R+	6.6699E-04	5.0E-09	2
24-04-13	299.2	5.3			23.79	1.5	45	5	33.31	0.5	15.01	-15.01	0.02	0.01	R-	6.6643E-04	5.7E-09	2
24-04-13															RM	6.6669E-04	3.6E-09	2
25-04-13	300.4	1.3			23.2	1.5	45	5	33.68	0.5	15.01	-15.01	0.02	0.01	R+	6.6699E-04	5.6E-09	2
25-04-13	299.3	5.3			23.2	1.5	45	5	33.68	0.5	15.01	-15.01	0.02	0.01	R-	6.6642E-04	1.6E-08	2
25-04-13															RM	6.6668E-04	8.6E-09	2

Nominal value primary current = 300 A and secondary current = 200 mA																		
Date	Primary current (A)	$u(I_1)$ (A)	Guideline resistance ( $\Omega$ )	$u(R_s)$ ( $\Omega$ )	LEM resistance ( $\Omega$ )	$u(R_L)$ ( $\Omega$ )	Voltage ratio k (-)	$u(k)$ (-)	Guideline ratio		Power supply		$u(PS)^{III}$ (V)	Power supply variation (%)	Measurement result (Ratio value) <sup>III</sup>	Extended standard uncertainty U (Ratio uncertainty)	Coverage factor k (95%)	
									(-)	(-)	+15 V (V)	-15 V (V)						
23-04-13	300.3	1.3	1.00007571	1.2E-07	2.00092396	3.9E-07	1.33390404	5.6E-06	999.997	0.007	15.01	-15.01	0.02	0.01	R+	6.6699E-04	5.5E-09	2
23-04-13	300.4	5.3	1.00007571	1.2E-07	2.00092396	3.9E-07	1.333794925	1.9E-06	999.997	0.007	15.01	-15.01	0.02	0.01	R-	6.6642E-04	4.8E-09	2
23-04-13															RM	6.6669E-04	3.6E-09	2
24-04-13	300.9	1.3	1.00007571	1.2E-07	2.00092396	3.9E-07	1.33390188	3.7E-06	999.997	0.007	15.01	-15.01	0.02	0.01	R+	6.6699E-04	5.0E-09	2
24-04-13	299.2	5.3	1.00007571	1.2E-07	2.00092396	3.9E-07	1.33379784	4.9E-06	999.997	0.007	15.01	-15.01	0.02	0.01	R-	6.6643E-04	5.7E-09	2
24-04-13															RM	6.6669E-04	3.6E-09	2
25-04-13	300.4	1.3	1.00007571	1.2E-07	2.00092396	3.9E-07	1.333907314	6.0E-06	999.997	0.007	15.01	-15.01	0.02	0.01	R+	6.6699E-04	5.6E-09	2
25-04-13	299.3	5.3	1.00007571	1.2E-07	2.00092396	3.9E-07	1.333798175	3.1E-05	999.997	0.007	15.01	-15.01	0.02	0.01	R-	6.6642E-04	1.6E-08	2
25-04-13															RM	6.6668E-04	8.6E-09	2

Nominal value primary current = 600 A and secondary current = 400 mA																		
Date	Primary current (A)	$u(I_1)$ (A)	Secondary current (A)	$u(I_2)$ (A)	Temperature (°C)	$u(T)^{III}$ (°C)	Humidity (%)	$u(H)^{III}$ (%)	Temperature LEM		Power supply		$u(PS)^{III}$ (V)	Power supply variation (%)	Measurement result (Ratio value) <sup>III</sup>	Extended standard uncertainty U (Ratio uncertainty)	Coverage factor k (95%)	
									(°C)	(°C)	+15 V (V)	-15 V (V)						
23-04-13	598.8	1.2			24.98	1.5	45	5	62.01	0.5	15.01	-15.01	0.02	0.01	R+	6.6699E-04	1.6E-08	2
23-04-13	601.2	4.3			24.98	1.5	45	5	62.01	0.5	15.01	-15.01	0.02	0.01	R-	6.6657E-04	1.5E-08	2
23-04-13															RM	6.6676E-04	1.1E-08	2
24-04-13	600.2	1.2			24.98	1.5	45	5	57.87	0.5	15.01	-15.01	0.02	0.01	R+	6.6699E-04	1.0E-08	2
24-04-13	604.5	4.3			24.98	1.5	45	5	57.87	0.5	15.01	-15.01	0.02	0.01	R-	6.6657E-04	9.8E-09	2
24-04-13															RM	6.6673E-04	7.0E-09	2
25-04-13	600.1	1.2			25.01	1.5	45	5	57.33	0.5	15.01	-15.01	0.02	0.01	R+	6.6699E-04	1.6E-08	2
25-04-13	602.9	4.3			25.01	1.5	45	5	57.33	0.5	15.01	-15.01	0.02	0.01	R-	6.6656E-04	1.3E-08	2
25-04-13															RM	6.6675E-04	1.0E-08	2

Nominal value primary current = 600 A and secondary current = 400 mA																		
Date	Primary current (A)	$u(I_1)$ (A)	Guideline resistance ( $\Omega$ )	$u(R_s)$ ( $\Omega$ )	LEM resistance ( $\Omega$ )	$u(R_L)$ ( $\Omega$ )	Voltage ratio k (-)	$u(k)$ (-)	Guideline ratio		Power supply		$u(PS)^{III}$ (V)	Power supply variation (%)	Measurement result (Ratio value) <sup>III</sup>	Extended standard uncertainty U (Ratio uncertainty)	Coverage factor k (95%)	
									(-)	(-)	+15 V (V)	-15 V (V)						
23-04-13	598.8	1.2	1.00007854	1.3E-07	2.0009384	3.8E-07	1.33390988	2.6E-05	999.997	0.014	15.01	-15.01	0.02	0.01	R+	6.6699E-04	1.6E-08	2
23-04-13	601.2	4.3	1.00007854	1.3E-07	2.0009384	3.8E-07	1.333830188	2.3E-05	999.997	0.014	15.01	-15.01	0.02	0.01	R-	6.6657E-04	1.5E-08	2
23-04-13															RM	6.6676E-04	1.1E-08	2
24-04-13	600.2	1.2	1.00007854	1.3E-07	2.0009384	3.8E-07	1.33389855	9.6E-06	999.997	0.014	15.01	-15.01	0.02	0.01	R+	6.6699E-04	1.0E-08	2
24-04-13	604.5	4.3	1.00007854	1.3E-07	2.0009384	3.8E-07	1.33383110	6.4E-06	999.997	0.014	15.01	-15.01	0.02	0.01	R-	6.6657E-04	9.8E-09	2
24-04-13															RM	6.6673E-04	7.0E-09	2
25-04-13	600.1	1.2	1.00007854	1.3E-07	2.0009384	3.8E-07	1.33390265	2.6E-05	999.997	0.014	15.01	-15.01	0.02	0.01	R+	6.6699E-04	1.6E-08	2
25-04-13	602.9	4.3	1.00007854	1.3E-07	2.0009384	3.8E-07	1.333829833	1.8E-05	999.997	0.014	15.01	-15.01	0.02	0.01	R-	6.6656E-04	1.3E-08	2
25-04-13															RM	6.6675E-04	1.0E-08	2

## 6. METAS – Federal Institute of Metrology METAS (Switzerland)

### 6.1 Measurement results

**Loop 1:** The results for the measured current ratio are represented as deviation with respect to the nominal value:

$$\Delta R/R_{nom} = (R_m - R_{nom})/R_{nom}$$

Where  $R_m$  is the measured ratio and  $R_{nom}$  its nominal value (1/1500). In the following we define:

T: temperature measured on the primary current bus (uncertainty  $\pm 0.1$  °C, rect. distribution )

H: relative humidity (uncertainty  $\pm 5\%$ , rect. distribution)

V+: +15 V power supply (uncertainty  $\pm 10$  mV, rect. distribution)

V-: -15 V power supply (uncertainty  $\pm 10$  mV, rect. distribution)

The primary current is positive when it flows in the direction of the arrow marked on the housing of the unit under test.

Date	I (A)	T (°C)	H (%)	V+ (V)	V- (V)	$\Delta R/R_{nom}$ ( $10^{-6}$ )	$U_{.95}$ ( $10^{-6}$ )
07.05.2013	90	24.2	37.3	15.01	-15.01	-0.8	3.1
07.05.2013	-90	24.5	37.3	15.01	-15.01	0.9	3.5
13.05.2013	300	25.5	33.2	15.00	-15.01	0.9	3.1
08.05.2013	-300	25.5	36.5	15.01	-15.01	0.0	4.4
17.05.2013	600	33.5	36.0	15.00	-15.02	1.7	3.8
21.05.2013	-600	34.8	35.6	15.03	-15.04	0.6	4.9

**Loop 2:** The results for the measured current ratio are represented as deviation with respect to the nominal value:

$$\infty R/R_{nom} = R_m \cdot R_{nom} / R_{nom}$$

Where  $R_m$  is the measured ratio and  $R_{nom}$  its nominal value (1/1500).

#### Method 1

Method 1 was used to measure the current ratios distinguishing positive and negative currents. In the following we define:

T: temperature measured on the primary current bus (uncertainty  $\pm 0.1$  °C, rect. distribution )

H: relative humidity (uncertainty  $\pm 5\%$ , rect. distribution)

V+: +15 V power supply (uncertainty  $\pm 10$  mV, rect. distribution)

V-: -15 V power supply (uncertainty  $\pm 10$  mV, rect. distribution)

The primary current is positive when it flows in the direction of the arrow marked on the housing of the unit under test.

Date	I (A)	T (°C)	H (%)	V+ (V)	V- (V)	$\infty R/R_{nom}$ ( $10^{-6}$ )	$U_{.95}$ ( $10^{-6}$ )
26.09.2014	90	25.1	37.3	15.01	-15.01	0.1	1.6
29.09.2014	-90	25.6	37.3	15.01	-15.01	-0.1	1.6
02.10.2014	300	26.7	37.2	14.99	-15.02	0.3	2.0
03.10.2014	-300	27.3	36.8	15.00	-15.01	0.6	2.0
06.10.2014	600	40.7	36.7	15.03	-15.02	0.3	2.3
06.10.2014	-600	39.0	37.1	15.03	-15.01	0.1	2.3

**Method 2**

Method 2 was used to measure  $R_{av}$ . In the following we define:

T: temperature on the primary current bus, this temperature was not measured when applying method 2. It is estimated as the average of the temperatures achieved for the two current polarities in method 1 (uncertainty  $\pm 0.5$  °C, rectangular distribution)

H: relative humidity, this quantity was not measured when applying method 2. It is estimated at 37.5% (uncertainty  $\pm 10\%$ , rectangular distribution)

V+: +15 V power supply

V-: -15 V power supply: these voltages were not measured when applying method 2. They are estimated at the nominal values of +15 V and -15 V (uncertainty  $\pm 0.02$  V, rectangular distribution)

Date	Abs(I) (A)	T (°C)	H (%)	V+ (V)	V- (V)	$\propto R_{av}/R_{nom}$ ( $10^{-6}$ )	$U_{.95}$ ( $10^{-6}$ )
04.12.2014	90	25.4	37.5	15.00	-15.00	0.02	0.7
05.12.2014	300	27.0	37.5	15.00	-15.00	-0.12	0.7
08.12.2014	600	39.8	37.5	15.00	-15.00	0.12	0.7

**6.1 Excel tables**

**Loop 1:**

Laboratory: METAS Rnom 6.66667E-04  
 Standard: LEM IT-600 S  
 sn: 810008322

Detailed Measurement Results

Nominal value primary current = 90 A and secondary current = 60 mA																
Date	Primary current (A)	$u(I_p)$ (A)	Secondary current (A)	$u(I_s)$ (A)	Temperature (°C)	$u(T)^{rel}$ (%)	Humidity (%)	$u(H)^{rel}$ (%)	Power supply +15 V (V)	-15 V (V)	$u(PS)^{rel}$ (%)	Power supply variation (%)	Measurement result (Ratio value) <sup>rel</sup>	Extended standard uncertainty U (Ratio uncertainty)	Coverage factor k (95%)	
07-05-13	90.00364	0.00012	0.06000238	5E-08	24.22	0.1	37.3	5	15.01	-15.01	0.01		R+	6.666671E-04	2.1E-09	2.02
07-05-13	-90.00420	0.00014	-0.060002857	7E-08	24.48	0.1	37.3	5	15.00	-15.01	0.01		R-	6.666673E-04	2.3E-09	2.02
													R <sub>1</sub>	6.66667E-04	1.8E-09	

Nominal value primary current = 300 A and secondary current = 200 mA																
Date	Primary current (A)	$u(I_p)$ (A)	Secondary current (A)	$u(I_s)$ (A)	Temperature (°C)	$u(T)^{rel}$ (%)	Humidity (%)	$u(H)^{rel}$ (%)	Power supply +15 V (V)	-15 V (V)	$u(PS)^{rel}$ (%)	Power supply variation (%)	Measurement result (Ratio value) <sup>rel</sup>	Extended standard uncertainty U (Ratio uncertainty)	Coverage factor k (95%)	
13-05-13	300.16916	0.00042	0.20011295	1.6E-07	25.49	0.1	33.2	5	15.00	-15.01	0.01		R+	6.666673E-04	2.1E-09	2.02
08-05-13	-300.16907	0.00063	-0.20011271	3.2E-07	25.53	0.15	36.5	5	15.01	-15.01	0.01		R-	6.66667E-04	2.9E-09	2.02
													R <sub>1</sub>	6.666670E-04	1.8E-09	

Nominal value primary current = 600 A and secondary current = 400 mA																
Date	Primary current (A)	$u(I_p)$ (A)	Secondary current (A)	$u(I_s)$ (A)	Temperature (°C)	$u(T)^{rel}$ (%)	Humidity (%)	$u(H)^{rel}$ (%)	Power supply +15 V (V)	-15 V (V)	$u(PS)^{rel}$ (%)	Power supply variation (%)	Measurement result (Ratio value) <sup>rel</sup>	Extended standard uncertainty U (Ratio uncertainty)	Coverage factor k (95%)	
17-05-13	600.13416	0.00102	0.40009012	3.2E-07	33.5	0.1	36	5	15.00	-15.02	0.01		R+	6.666678E-04	2.5E-09	2.11
21-05-13	-600.13368	0.00138	-0.40000889	6E-07	34.8	0.1	36	5	15.03	-15.03	0.01		R-	6.666663E-04	3.3E-09	2.11
													R <sub>1</sub>	6.666670E-04	2.1E-09	

**Loop 2:**

Laboratory: METAS Rnom= 1/1500  
 Standard: LEM IT-600 S  
 sn: 713552000.0

Detailed Measurement Results

Nominal value primary current = 90 A and secondary current = 60 mA																
Date	Primary current (A)	$u(I_p)$ (A)	Secondary current (A)	$u(I_s)$ (A)	Temperature (°C)	$u(T)^{rel}$ (%)	Humidity (%)	$u(H)^{rel}$ (%)	Power supply +15 V (V)	-15 V (V)	$u(PS)^{rel}$ (%)	Power supply variation (%)	Measurement result (Ratio value) <sup>rel</sup>	Extended standard uncertainty U (Ratio uncertainty)	Coverage factor k (95%)	
26-09-14	90.00000		0.06000001	5E-08	25.1	0.1	37	5	15.01	-15.01	0.01		R+	6.666668E-04	1.1E-09	2.02
29-09-14	-90.00000		-0.05999999	5E-08	25.6	0.1	37	5	15.00	-15.01	0.01		R-	6.66666E-04	1.1E-09	2.02
													R <sub>1</sub>			

Nominal value primary current = 300 A and secondary current = 200 mA																
Date	Primary current (A)	$u(I_p)$ (A)	Secondary current (A)	$u(I_s)$ (A)	Temperature (°C)	$u(T)^{rel}$ (%)	Humidity (%)	$u(H)^{rel}$ (%)	Power supply +15 V (V)	-15 V (V)	$u(PS)^{rel}$ (%)	Power supply variation (%)	Measurement result (Ratio value) <sup>rel</sup>	Extended standard uncertainty U (Ratio uncertainty)	Coverage factor k (95%)	
02-10-14	300.00000		0.20000007	2.0E-07	26.7	0.1	37	5	14.99	-15.02	0.01		R+	6.666669E-04	1.3E-09	2.06
03-10-14	-300.00000		-0.20000012	2.0E-07	27.3	0.1	37	5	15.00	-15.01	0.01		R-	6.666671E-04	1.3E-09	2.06
													R <sub>1</sub>			

Nominal value primary current = 600 A and secondary current = 400 mA																
Date	Primary current (A)	$u(I_p)$ (A)	Secondary current (A)	$u(I_s)$ (A)	Temperature (°C)	$u(T)^{rel}$ (%)	Humidity (%)	$u(H)^{rel}$ (%)	Power supply +15 V (V)	-15 V (V)	$u(PS)^{rel}$ (%)	Power supply variation (%)	Measurement result (Ratio value) <sup>rel</sup>	Extended standard uncertainty U (Ratio uncertainty)	Coverage factor k (95%)	
06-10-14	600.00000		0.40000014	4.6E-07	40.7	0.1	37	5	15.03	-15.01	0.01		R+	6.666669E-04	1.5E-09	2.09
06-10-14	-600.00000		-0.40000006	4.6E-07	39.0	0.1	37	5	15.03	-15.01	0.01		R-	6.666668E-04	1.5E-09	2.09
													R <sub>1</sub>			

## 7. MIKES – Centre for Metrology and Accreditation (Finland)

### 7.1 Calibration results

Summary of the results is given in table 1.

Table 1: Summary of the results.

Mean date	Nominal current	Measured current ratio	Uncertainty $k=2$	Measured current ratio	Uncertainty $k=2$	Measured current ratio	Uncertainty $k=2$
dd.m.yyyy	A	$R_x$ A/A	$U(R_x)$ A/A	$R_x$ A/A	$U(R_x)$ A/A	$R_M$ A/A	$U(R_M)$ A/A
20.1.2014	90	6.666635E-04	8.8E-09	6.666619E-04	9.6E-09	6.666627E-04	9.0E-09
23.1.2014	300	6.666626E-04	4.2E-09	6.666635E-04	6.0E-09	6.666631E-04	4.2E-09
22.1.2014	600	6.666643E-04	4.0E-09	6.666636E-04	4.4E-09	6.666639E-04	4.1E-09

Uncertainty budgets are given in Tables 2-10. The coverage factor of the uncertainty corresponds a coverage probability of 95 %. The uncertainty has been evaluated according to the "Evaluation of measurement data - Guide to the expression of uncertainty in measurement" (JCGM 100:2008) which is compatible with the EA-4/02 defined in the comparison protocol.

The numerical values in the budgets are not the averages of all measurements during the MIKES measurement period. Instead, results of selected typical measurements with lowest uncertainty are presented.

A visual summary of the results are given in figures 2-5. Black markers show the relative deviations (ppm) of the average results from the nominal value of 1/1500. Linear fit is shown as a thin black line. The results look very consistent because the individual black markers are closer than 1 ppm from the linear fits.

All the uncertainty bars are  $k=2$  values. The uncertainties and variation of the results are largest at 90 A and smallest at 600 A. This is because the uncertainties of the measured voltages are dominant at 90 A.

The results are practically not dependent on current level. The slight rise in the linear fits is clearly smaller than the uncertainty level of the results.

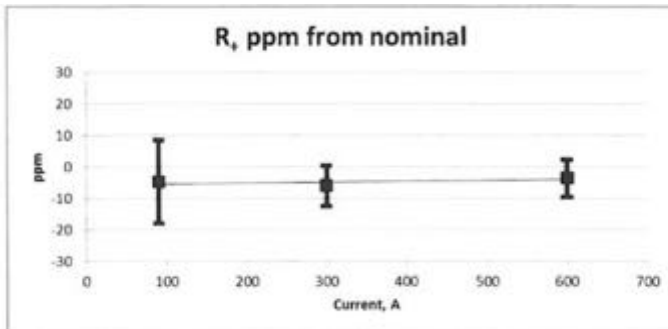

Figure 3: Secondary to primary current ratios for positive currents.

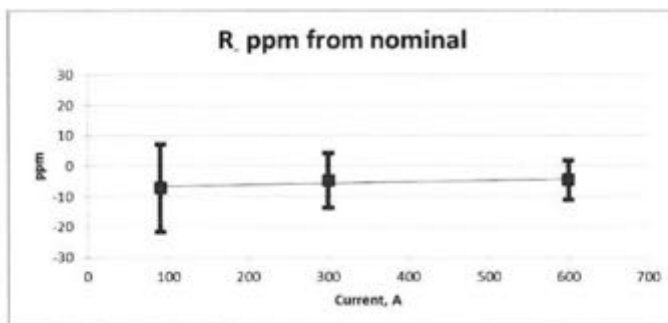

Figure 4: Secondary to primary current ratios for negative currents.

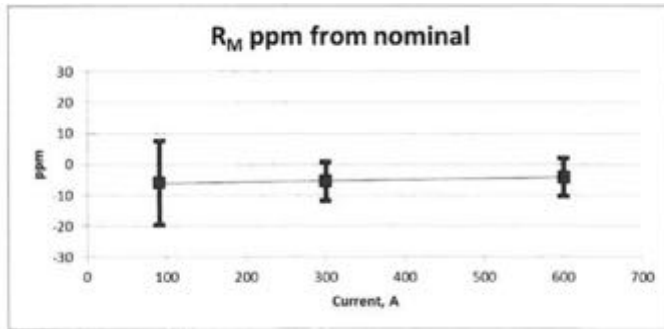

Figure 5: Secondary to primary current ratios for mean values of positive and negative currents.

## 7.2 Excel tables

Laboratory: MIKES

Standard: LEM IT-600 S  
sn: 8100088322

### Detailed Measurement Results

Nominal value primary current = 90 A and secondary current = 60 mA														Measurement result	Extended standard uncertainty <i>U</i>	Coverage factor <i>k</i>
Date	Primary current	<i>u(I<sub>p</sub>)</i>	Secondary current	<i>u(I<sub>s</sub>)</i>	Temperature	<i>u(T)</i> <sup>(2)</sup>	Humidity	<i>u(H)</i> <sup>(2)</sup>	Power supply		<i>u(PS)</i> <sup>(2)</sup>	Power supply variation	(Ratio value) <sup>(3)</sup>			
	(A)	(A)	(A)	(A)	(°C)	(°C)	(%)	(%)	+15 V	-15 V	(V)	(%)	(V)			
20-01-2014	90.02800	0.00048	0.06001838	0.00000021	25	2.0	38.5	2.0	15.06	-15.43	0.003	0.1	<i>R</i> <sub>+</sub>	6.666635E-04	8.8E-09	2
20-01-2014	-90.03497	0.00048	-0.06002288	0.00000021	25	2.0	38.5	2.0	15.07	-15.42	0.003	0.1	<i>R</i> <sub>-</sub>	6.666619E-04	9.6E-09	2
													<i>R<sub>M</sub></i>	6.666627E-04	9.0E-09	2

Nominal value primary current = 300 A and secondary current = 200 mA														Measurement result	Extended standard uncertainty <i>U</i>	Coverage factor <i>k</i>
Date	Primary current	<i>u(I<sub>p</sub>)</i>	Secondary current	<i>u(I<sub>s</sub>)</i>	Temperature	<i>u(T)</i> <sup>(2)</sup>	Humidity	<i>u(H)</i> <sup>(2)</sup>	Power supply		<i>u(PS)</i> <sup>(2)</sup>	Power supply variation	(Ratio value) <sup>(3)</sup>			
	(A)	(A)	(A)	(A)	(°C)	(°C)	(%)	(%)	+15 V	-15 V	(V)	(%)	(V)			
23-01-2014	300.11714	0.00070	0.20007689	0.00000045	30.7	2.0	38.5	2.0	15.02	-15.44	0.003	0.1	<i>R</i> <sub>+</sub>	6.666626E-04	4.2E-09	2
23-01-2014	-300.05861	0.00070	-0.20003812	0.00000045	30.7	2.0	38.5	2.0	15.07	-15.41	0.003	0.1	<i>R</i> <sub>-</sub>	6.666635E-04	6.0E-09	2.13
													<i>R<sub>M</sub></i>	6.666631E-04	4.2E-09	2

Nominal value primary current = 600 A and secondary current = 400 mA														Measurement result	Extended standard uncertainty <i>U</i>	Coverage factor <i>k</i>
Date	Primary current	<i>u(I<sub>p</sub>)</i>	Secondary current	<i>u(I<sub>s</sub>)</i>	Temperature	<i>u(T)</i> <sup>(2)</sup>	Humidity	<i>u(H)</i> <sup>(2)</sup>	Power supply		<i>u(PS)</i> <sup>(2)</sup>	Power supply variation	(Ratio value) <sup>(3)</sup>			
	(A)	(A)	(A)	(A)	(°C)	(°C)	(%)	(%)	+15 V	-15 V	(V)	(%)	(V)			
22-01-2014	600.0887	0.0014	0.40005772	0.00000088	32.5	2.0	38.5	2.0	14.98	-15.45	0.003	0.1	<i>R</i> <sub>+</sub>	6.666643E-04	4.0E-09	2
22-01-2014	-600.0931	0.0014	-0.40006025	0.00000088	32.5	2.0	38.5	2.0	15.08	-15.38	0.003	0.1	<i>R</i> <sub>-</sub>	6.666636E-04	4.4E-09	2
													<i>R<sub>M</sub></i>	6.666639E-04	4.1E-09	2

Date is the mean date of measurements used to calculate the results on than row.

Primary current and Secondary current are the averages of the currents of measurements used to calculate the results on than row.

*u(I<sub>p</sub>)* and *u(I<sub>s</sub>)* are the averages of the uncertainties of currents used to calculate the results on than row.

Temperature is the average of the temperatures measured on the surface of the primary conductor from some point inside the hole of the travelling ZFCT. Defining of temperature is problematic in many ways. There are large transients in temperature and moving the sensor just for a couple of cm has large effect on results. Temperatures when using different numbers of turns and different cross sectional areas will cause largely different amounts of heating. Using the vacuum cleaner to cool the conductor naturally has large effect. In the short measurements the cables warm up only a fraction of the amount of warming in steady state measurements.

It is clear that average of all these measurements with different circumstances does not describe very well all this diversity. It was not obvious what would be a meaningful way to define the temperature required in the result table. Here it was done by calculating first the averages of the temperatures of each measurement at certain current (8 measurements at 90 A, 7 measurements at 300 A and 6 measurements at 600 A) from the periods when the current was on, in other words the temperature of the zero measurements was not used.

Then the averages of these 6, 7 or 8 results were calculated and they are given as mean temperatures stated at the result table. The average temperatures varied from 24 °C to 29 °C for 90 A, from 25 °C to 38 °C for 300 A and 30 °C to 35 °C for 600 A.

$u(T)$  is the uncertainty of temperature averages. It was very roughly estimated to be 2 °C,  $k=1$ . It is dominated by the uncertainty caused by the temperature variation in different points of the conductor surface while the sensor measures at just one more or less arbitrarily selected point. Uncertainty of the sensor is not significant.

**Humidity** was measured from the incoming air of the laboratory so it represents the relative humidity at 22.5 °C, not at the temperature on the primary conductor surface. Calibration of the sensor was also outdated so the results cannot be considered strictly traceable, but because no significant influence was not expected no extra work was done to get more reliable values.

$u(H)$  is the uncertainty of humidity. It was very roughly estimated to be 2 %,  $k=1$ .

**Power supply (V)** values were obtained as explained in paragraph 2.2.6.

$u(PS)$  is the uncertainty of the power supply voltages. It comes directly from the 0.01 V resolution of the stated power supply values.

**Power supply variation (%)** values are the rounded up peak-to-peak values obtained from the change of measured supply voltages during the following minutes after switching on the test current. As the power supply variation is measured only once there is no information about the supply voltages on different times and different setups and the stated variation does not cover them.

**Measurement results** are the averages of the results calculated according to the formula (3).

**Extended standard uncertainties** are calculated according to the JCGM 100:2008.

**Coverage factors** are selected according to the JCGM 100:2008.

## 8. PTB – Physikalisch-Technische Bundesanstalt (Germany)

### 8.1 Results and environmental conditions

Results for LEM IT-600 S, Ser.No. 8100088322, test current 90 A :

nom. value	mean date of measurement	mean temperature	mean humidity	mean result	expanded uncertainty (k=2)
R+	2013-03-18	(23,2 ± 0,2) °C	20%	6,666 666 · 10 <sup>-4</sup>	2 · 10 <sup>-9</sup>
R-				6,666 681 · 10 <sup>-4</sup>	
R <sub>M</sub>				6,666 673 · 10 <sup>-4</sup>	

The voltages for the power supply were +15.00 V and -15.00 V with an expanded uncertainty of 0.02 V. During the period of measurement, the relative humidity varied within 15% and 25% with an uncertainty of 5%.

### 8.2 Appendix: detailed results

Date	I <sub>P+</sub> / A	I <sub>P-</sub> / A	I <sub>S+</sub> / A	I <sub>S-</sub> / A	I <sub>SO</sub> / A	R <sub>P</sub> /Ω ??	R <sub>M</sub> /Ω ??	R/Ω ??
12.03.2013 08:00	90,00220	-90,00266	0,05999939	-0,06000397	-2,05E-06	6,666665E-04	6,666682E-04	6,666674E-04
13.03.2013 13:00	90,00228	-90,00274	0,05999933	-0,06000418	-2,22E-06	6,666670E-04	6,666682E-04	6,666676E-04
13.03.2013 17:00	90,00225	-90,00272	0,05999934	-0,06000407	-2,23E-06	6,666674E-04	6,666670E-04	6,666672E-04
14.03.2013 13:00	90,00213	-90,00281	0,05999913	-0,06000428	-2,18E-06	6,666654E-04	6,666692E-04	6,666673E-04
14.03.2013 17:00	90,00228	-90,00267	0,05999932	-0,06000416	-2,22E-06	6,666669E-04	6,666685E-04	6,666677E-04
15.03.2013 08:00	90,00230	-90,00264	0,05999935	-0,06000411	-2,21E-06	6,666670E-04	6,666681E-04	6,666676E-04
18.03.2013 08:00	90,00198	-90,00293	0,05999915	-0,06000422	-2,17E-06	6,666666E-04	6,666678E-04	6,666672E-04
18.03.2013 13:00	90,00214	-90,00276	0,05999924	-0,06000409	-2,16E-06	6,666664E-04	6,666677E-04	6,666670E-04
21.03.2013 08:00	90,00214	-90,00284	0,05999903	-0,06000436	-2,24E-06	6,666649E-04	6,666692E-04	6,666670E-04
21.03.2013 13:00	90,00219	-90,00286	0,05999927	-0,06000423	-2,24E-06	6,666672E-04	6,666676E-04	6,666674E-04
22.03.2013 08:00	90,00246	-90,00295	0,05999998	-0,06000369	-2,04E-06	6,666668E-04	6,666672E-04	6,666670E-04
25.03.2013 08:00	90,00239	-90,00301	0,06000001	-0,06000369	-2,11E-06	6,666666E-04	6,666679E-04	6,666673E-04
25.03.2013 16:00	90,00236	-90,00298	0,05999948	-0,06000424	-2,12E-06	6,666671E-04	6,666681E-04	6,666676E-04
Mean	90,00224	-90,00281	0,05999939	-0,06000410	-2,16846E-06	6,666666E-04	6,666681E-04	6,666673E-04
relative Type A	3,5E-05	3,5E-05	8,2E-08	5,7E-08	1,9E-08	2,0E-10	1,8E-10	6,4E-11

### 8.3 Excel tables

Laboratory: **PTB**

Standard: LEM IT-600 S  
sn: 8100088322

Detailed Measurement Results

Nominal value primary current = 90 A and secondary current = 60 mA																
Date	Primary current (A)	u(I <sub>p</sub> ) (A)	Secondary current (A)	u(I <sub>s</sub> ) (A)	Temperature (°C)	u(T) <sup>(rel)</sup> (°C)	Humidity (%)	u(H) <sup>(rel)</sup> (%)	Power supply +15 V -15 V (V)		u(PS) <sup>(rel)</sup> (V)	Power supply variation (%)	Measurement result (Ratio value) <sup>(rel)</sup>	Extended standard uncertainty U (Ratio uncertainty)	Coverage factor k (95%)	
18-03-13	90,00224	1,60E-04	6,00E-02	2,80E-07	23,2	0,1	20	5	15	-15	0,01	0,05	R+	6,67E-04	2,00E-09	2
18-03-13	-90,00281	1,60E-04	-6,00E-02	2,60E-07	23,2	0,1	20	5	15	-15	0,01	0,05	R-	6,67E-04	2,00E-09	2
													R <sub>M</sub>	6,67E-04	2,00E-09	2

## 9. SIQ – Slovenian Institute of Quality and Metrology (Slovenia)

### 9.1 Results

**Ratio:**

$$R_+(90) = 6,666628 \cdot 10^{-4} + 1,4 \cdot 10^{-8}$$

$$R_-(90) = 6,666615 \cdot 10^{-4} + 1,4 \cdot 10^{-8}$$

$$R(90) = 6,666621 \cdot 10^{-4} + 1,4 \cdot 10^{-8}$$

$$R_+(300) = 6,666637 \cdot 10^{-4} + 1,2 \cdot 10^{-8}$$

$$R_-(300) = 6,666617 \cdot 10^{-4} + 1,2 \cdot 10^{-8}$$

$$R(300) = 6,666627 \cdot 10^{-4} + 1,2 \cdot 10^{-8}$$

### 9.2 Excel tables

Laboratory: SIQ

Standard: LEM IT-600 S  
sn: 8100088322

Detailed Measurement Results

Nominal value primary current = 90 A and secondary current = 60 mA																
Date	Primary current (A)	$u(I_p)$ (A)	Secondary current (A)	$u(I_s)$ (A)	Temperature (°C)	$u(T)^{rel}$ (°C)	Humidity (%)	$u(H)^{rel}$ (%)	Power supply +15 V (V)	-15 V (V)	$u(PS)^{rel}$ (V)	Power supply variation (%)	Measurement result (Ratio value) <sup>rel</sup>	Extended standard uncertainty U (Ratio uncertainty)	Coverage factor k (95%)	
09-06-15	90,0054	0,0015	0,0600033	0,0000008	23,6	2	48,2	2	15,009	-14,989	0,002	0,02	R+	6,666628E-04	1,4E-08	2
09-06-15	-90,0060	0,0015	-0,0600035	0,0000008	23,5	2	48,6	2	15,008	-14,990	0,002	0,02	R-	6,666615E-04	1,4E-08	2
													R <sub>+</sub>	6,666621E-04	1,4E-08	2

Nominal value primary current = 300 A and secondary current = 200 mA																
Date	Primary current (A)	$u(I_p)$ (A)	Secondary current (A)	$u(I_s)$ (A)	Temperature (°C)	$u(T)^{rel}$ (°C)	Humidity (%)	$u(H)^{rel}$ (%)	Power supply +15 V (V)	-15 V (V)	$u(PS)^{rel}$ (V)	Power supply variation (%)	Measurement result (Ratio value) <sup>rel</sup>	Extended standard uncertainty U (Ratio uncertainty)	Coverage factor k (95%)	
10-06-15	299,9951	0,0045	0,1999959	0,0000016	26,9	2	49,1	2	15,007	-14,991	0,002	0,02	R+	6,666637E-04	1,2E-08	2
15-06-15	-299,9964	0,0045	-0,1999961	0,0000016	27,2	2	49,3	2	15,007	-14,990	0,002	0,02	R-	6,666617E-04	1,2E-08	2
													R <sub>+</sub>	6,666627E-04	1,2E-08	2

## 10. SP – SP Technical Research Institute of Sweden (Sweden)

### 10.1 Results

DC current comparator (LEM IT-600 S, s/n 8100088322)

Prim. curr. [A]	Temp. [°C]	Temp. Unc. (k=1) [°C]	Temp. Range of variation [°C]	Hum. [%]	Hum. Unc. (k=1) [%]	Hum. Range of var. [%]	Power supply [V]		Power supply Unc. (k=1) [V]	Power supply variation [V]	Mean date	Ratio value	Comb. std unc. (Ratio unc.)
90	25.2	±0.3	24.2 – 26.0	44	±4	42 – 46	+15.05	-15.01	±0.01	0.12	2013-01-17	6.666666·10 <sup>-4</sup>	1.5·10 <sup>-9</sup>
300	27.1	±1.2	26.1 – 28.9	43	±3	42 – 44	+15.03	-15.00	±0.01	0.14	2013-01-19	6.666668·10 <sup>-4</sup>	1.5·10 <sup>-9</sup>

### 10.2 Excel tables

Laboratory: **SP**

Standard: LEM IT-600 S  
sn: 8100088322

Detailed Measurement Results

Nominal value primary current = 90 A and secondary current = 60 mA																	
Date	Primary current (A)	$u(I_p)$ (A)	Secondary current (A)	$u(I_s)$ (A)	Temperature (°C)	$u(T)^{(2)}$ (°C)	Humidity (%)	$u(H)^{(2)}$ (%)	Power supply +15 V -15 V (V)	$u(PS)^{(2)}$ (V)	Power supply variation (%)	Measurement result (Ratio value) <sup>(3)</sup>	Extended standard uncertainty U (Ratio uncertainty)	Coverage factor k (95%)	Room temp near DUT (°C)	Room temp (°C)	
11-01-2013	90	0.04	0.06	0.00003	25.3	0.2	44	4	15.001	-14.963	0.004	0.075	$R_M$ 6.6666704E-04	2.71E-09	2.0	24.1	23.0
11-01-2013	90	0.04	0.06	0.00003	26.0	0.3	45	3	15.001	-14.964	0.003	0.057	$R_M$ 6.6666643E-04	2.71E-09	2.0	23.4	23.0
11-01-2013	90	0.05	0.06	0.00004	25.2	0.2	44	4	14.998	-14.961	0.004	0.082	$R_M$ 6.6666693E-04	2.71E-09	2.0	24.1	23.0
14-01-2013	90	0.05	0.06	0.00004	24.9	0.2	43	3	14.992	-14.955	0.003	0.050	$R_M$ 6.6666701E-04	2.71E-09	2.0	24.3	22.8
14-01-2013	90	0.05	0.06	0.00004	25.0	0.3	43	3	15.000	-14.963	0.002	0.032	$R_M$ 6.6666644E-04	2.71E-09	2.0	23.7	22.8
17-01-2013	90	0.05	0.06	0.00004	25.3	0.2	42	3	15.105	-15.068	0.002	0.042	$R_M$ 6.666636E-04	2.82E-09	2.0	23.7	22.9
18-01-2013	90	0.03	0.06	0.00002	25.0	0.3	44	3	15.106	-15.069	0.002	0.022	$R_M$ 6.666666E-04	2.71E-09	2.0	23.6	23.1
18-01-2013	90	0.03	0.06	0.00002	25.6	0.2	43	3	15.107	-15.069	0.002	0.020	$R_M$ 6.6666653E-04	2.71E-09	2.0	24.2	23.2
21-01-2013	90	0.03	0.06	0.00002	25.5	0.2	44	3	15.103	-15.065	0.002	0.016	$R_M$ 6.6666612E-04	2.71E-09	2.0	23.9	23.3
31-01-2013	90	0.19	0.06	0.00013	24.9	0.3	44	3	15.058	-15.020	0.002	0.018	$R_M$ 6.666666E-04	2.71E-09	2.0	23.7	22.6
31-01-2013	90	1.3	0.06	0.00087	24.2	0.3	45	3	15.063	-15.025	0.002	0.033	$R_M$ 6.666670E-04	2.82E-09	2.0	23.6	22.5

Nominal value primary current = 300 A and secondary current = 200 mA																	
Date	Primary current (A)	$u(I_p)$ (A)	Secondary current (A)	$u(I_s)$ (A)	Temperature (°C)	$u(T)^{(2)}$ (°C)	Humidity (%)	$u(H)^{(2)}$ (%)	Power supply +15 V -15 V (V)	$u(PS)^{(2)}$ (V)	Power supply variation (%)	Measurement result (Ratio value) <sup>(3)</sup>	Extended standard uncertainty U (Ratio uncertainty)	Coverage factor k (95%)	Room temp near DUT (°C)	Room temp (°C)	
14-01-2013	300	0.09	0.2	0.00006	26.9	1.2	43	3	14.971	-14.933	0.002	0.041	$R_M$ 6.6666716E-04	2.82E-09	2.0	24.0	22.8
14-01-2013	300	0.09	0.2	0.00006	26.1	1.1	43	3	15.000	-14.962	0.002	0.035	$R_M$ 6.6666676E-04	2.82E-09	2.0	23.7	22.8
17-01-2013	300	0.09	0.2	0.00006	26.4	0.9	42	3	15.106	-15.068	0.003	0.056	$R_M$ 6.6666639E-04	2.82E-09	2.0	23.7	23.0
31-01-2013	300	0.2	0.2	0.00014	28.9	0.5	43	3	15.057	-15.019	0.002	0.028	$R_M$ 6.6666687E-04	2.82E-09	2.0	23.7	22.5

## 11. VSL – VSL Dutch Metrology Institute (Netherlands)

### 11.1 Measurement results

Sections in this chapter first give the results of the verification measurements, followed by the summarised results of the CT ratio measurements for the comparison. The CT ratio measurement values given are relative deviations from the nominal current ratio value of 1:1500, as requested in the comparison protocol.

#### VERIFICATION MEASUREMENTS

Figure 6 shows the 1:3 error at 90 A-turns (left graph), and the 3:6 error at 300 A-turns (right graph) respectively. It can be seen from these graphs, that a small but significant error is made in the step-up method. The 1:3 error and 3:6 error are  $(0.54 \pm 0.27)$  ppm and  $(0.23 \pm 0.14)$  ppm respectively ( $k = 1$  values). The final measurement values at 300 A and 600 A given in the next section have been corrected for these errors.

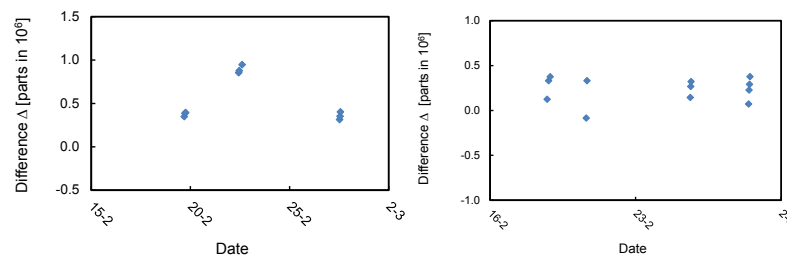

Figure 6. The 1:3 step-up error at 90 A-turns (left graph), and the 3:6 step-up error at 300 A-turns (right graph).

The second verification measurement concerned the effect of the primary current conductor position in the travelling standard. The table below gives the measured deviation from nominal value of the DC current ratio of the DUT, for 4 extreme out-of-centre positions of the primary current conductors within the central hole of the travelling standard. The peak-peak variation in measurement value for these positions is 1.6 ppm, with the average value of 0.2 ppm agreeing very well with the 0.4 ppm value measured with the primary current conductors placed in the central position on the same day this test was performed. The variation in the measurement results is used for estimating an uncertainty due to non-ideal centering of the current conductors.

Conductor position	Value
bottom	-0.6 ppm
top	1.0 ppm
left	-0.5 ppm
right	0.7 ppm
Average	0.2 ppm

### 11.2 Excel tables

Laboratory: VSL

Standard: LEM IT-600 S  
sn: 8100088322

#### Detailed Measurement Results

Nominal value primary current = 90 A and secondary current = 60 mA																
Date	Primary current (A)	$u(I_p)$ (A)	Secondary current (A)	$u(I_s)$ (A)	Temperature (°C)	$u(T)$ (°C)	Humidity (%)	$u(H)$ (%)	Power supply		$u(PS)$ (V)	Power supply variation (%)	Measurement result (Ratio value) <sup>III</sup>	Extended standard uncertainty $U$ (Ratio uncertainty)	Coverage factor $k$ (95%)	
									+15 V (V)	-15 V (V)						
26-feb-13	90,00	0.02	6.0000040E-02	2E-05	22,92	0,3	45	2,5	15,006	-15,006	0,005	0,015	R+	6,666662E-04	6,0E-10	2,0
26-feb-13	-90,00	0.02	6.0000039E-02	2E-05	22,88	0,3	45	2,5	15,006	-15,006	0,005	0,015	R-	6,666662E-04	6,0E-10	2,0
26-feb-13	90,00	0.02	6.0000023E-02	2E-05	23,08	0,3	45	2,5	15,006	-15,006	0,005	0,015	R <sub>M</sub>	6,666664E-04	6,0E-10	2,0

The table below gives the measured deviation from nominal value of the DC current ratio of the travelling standard at 90 A with extended ( $k = 2$ ) uncertainties in ppm.

	Measurement result (Ratio value) [ppm]	Extended standard uncertainty $U$ (Ratio uncertainty) [ppm]
R+	-0.66	0.9
R-	-0.66	0.9
R <sub>M</sub>	-0.38	0.9

Nominal value primary current = 300 A and secondary current = 200 mA															
Date	Primary current (A)	$u(I_p)$ (A)	Secondary current (A)	$u(I_s)$ (A)	Temperature (°C)	$u(T)^{III}$ (°C)	Humidity (%)	$u(H)^{III}$ (%)	Power supply +15 V -15 V (V)		$u(PS)^{III}$ (V)	Power supply variation (%)	Measurement result (Ratio value) <sup>III</sup>	Extended standard uncertainty U (Ratio uncertainty)	Coverage factor k (95%)
26-feb-13	297.00	0.06	0.19800000	6E-05	23.02	0.4	45	2.5	15.006	-15.006	0.005	0.015	$R_+$ 6.666663E-04	6.7E-10	2.0
26-feb-13	-297.00	0.06	0.19800002	6E-05	23.08	0.4	45	2.5	15.006	-15.006	0.005	0.015	$R_-$ 6.666662E-04	6.7E-10	2.0
22-feb-13	297.00	0.06	0.19799996	6E-05	23.59	0.4	45	2.5	15.006	-15.006	0.005	0.015	$R_M$ 6.666664E-04	6.7E-10	2.0

The table below gives the measured deviation from nominal value of the DC current ratio of the travelling standard at 300 A with extended ( $k = 2$ ) uncertainties in ppm.

Measurement result (Ratio value) [ppm]	Extended standard uncertainty U (Ratio uncertainty) [ppm]
$R_+$ -0.57	1.0
$R_-$ -0.68	1.0
$R_M$ -0.41	1.0

Nominal value primary current = 600 A and secondary current = 400 mA															
Date	Primary current (A)	$u(I_p)$ (A)	Secondary current (A)	$u(I_s)$ (A)	Temperature (°C)	$u(T)^{III}$ (°C)	Humidity (%)	$u(H)^{III}$ (%)	Power supply +15 V -15 V (V)		$u(PS)^{III}$ (V)	Power supply variation (%)	Measurement result (Ratio value) <sup>III</sup>	Extended standard uncertainty U (Ratio uncertainty)	Coverage factor k (95%)
27-feb-13	594.00	0.12	0.39599987	1.2E-04	22.99	1.0	45	2.5	15.006	-15.006	0.005	0.015	$R_+$ 6.666662E-04	7.3E-10	2.0
27-feb-13	-594.00	0.12	0.39599995	1.2E-04	22.94	1.0	45	2.5	15.006	-15.006	0.005	0.015	$R_-$ 6.666660E-04	7.3E-10	2.0
24-feb-13	594.00	0.12	0.39599983	1.2E-04	24.17	1.0	45	2.5	15.006	-15.006	0.005	0.015	$R_M$ 6.666662E-04	7.3E-10	2.0

The table below gives the measured deviation from nominal value of the DC current ratio of the travelling standard at 600 A with extended ( $k = 2$ ) uncertainties in ppm.

Measurement result (Ratio value) <sup>(3)</sup> [ppm]	Extended standard uncertainty U (Ratio uncertainty) [ppm]
$R_+$ -0.75	1.1
$R_-$ -0.95	1.1
$R_M$ -0.63	1.1

**Supplementary Comparison EURAMET.EM-35  
Comparison of High-Current Ratio Standard**

**FINAL REPORT – ANNEX B  
Methods of measurement**

C. Cassiago<sup>a</sup> and A. Mortara<sup>b</sup>

a Istituto Nazionale di Ricerca Metrologica, INRIM  
Strada delle Cacce 91, 10135 Turin, Italy

b Federal Institute of Metrology, METAS  
Lindenweg 50, 3003 Bern-Wabern, Switzerland

## Table of Contents

1. Introduction .....	3
2. CMI – Czech Metrology Institute (Czech Republic) .....	3
2.1 Measurement set-up .....	3
3. INRIM – Istituto Nazionale di Ricerca Metrologica (Italy).....	4
3.1 Measurement set-up .....	4
3.2 Measurement method .....	4
3.3 Measurement traceability .....	5
3.4 References .....	6
4. LCOE – Laboratorio Central Oficial de Electrotecnia (Spain).....	7
4.1 Measurement set-up .....	7
4.2 Traceability scheme .....	9
4.3 Measurement procedure .....	9
5. LNE – Laboratoire national de métrologie et d’essais (France) .....	11
5.1 Measurement set-up, procedure and traceability at 90 A.....	11
5.2 Measurement set-up, procedure and traceability at 300 A and 600 A.....	12
6. METAS – Federal Institute of Metrology METAS (Switzerland).....	14
6.1 Measurement set-up and procedure .....	14
6.2 Measurement traceability .....	14
6.3 Measurement conditions .....	15
7. MIKES – Centre for Metrology and Accreditation (Finland).....	16
7.1 Calibration method.....	16
7.2 Some measurement practices .....	18
7.3 Measurement standards used in calibration and traceability.....	19
7.4 Measurement conditions .....	20
7.1 Appendix 1 .....	20
8. PTB – Physikalisch-Technische Bundesanstalt (Germany).....	22
8.1 Measurement procedure and Traceability scheme.....	22
8.2 Measurement set-up for the calibration of high current measuring instruments .....	22
9. SIQ – Slovenian Institute of Quality and Metrology (Slovenia).....	23
9.1 Reference standards .....	23
9.2 Measurement procedure .....	23
9.3 Traceability .....	25
9.4 Ambient conditions .....	25
10. SP – SP Technical Research Institute of Sweden (Sweden) .....	26
10.1 Traceability scheme .....	26
10.2 Measurement set-up .....	26
10.3 Measurement procedure .....	27
11. VSL – VSL Dutch Metrology Institute (Netherlands).....	28
11.1 Environment.....	28
11.2 Measurement method .....	30
11.3 References .....	33

## 1. Introduction

This is the list of the methods of measurement and the step-up procedures used by each participant (sorted alphabetically by participant acronym), extracted from their comparison reports.

## 2. CMI – Czech Metrology Institute (Czech Republic)

### 2.1 Measurement set-up

Measurement set-up is given in Figs.1 and 2. The circuit of the primary current  $I_P$  is powered from an adjustable current source. The value of the current  $I_P$  was determined from a voltage drop  $U_{RN1}$  across a standard resistor  $R_{N1}$ . The voltages  $U_{RN1}$  and  $U_{RN2}$  were measured using two simultaneously triggered Agilent 3458A multimeters. The measurement for one value of primary current (eg. 300 A) was divided to two parts:

1. In the first part were performed 10 measurements for positive polarity of measured current. Thereafter the primary current  $I_P$  was switched-off and the voltage  $U_{RN20}$  across the resistor  $R_{N2}$  corresponding to the current  $I_{off}$  was measured.
2. In the second part was the output of the current source commutated and 10 measurements for negative polarity of measured current was performed. Thereafter the primary current  $I_P$  was switched-off and the voltage  $U_{RN20}$  across the resistor  $R_{N2}$  corresponding to the current  $I_{off}$  was measured.

Three sets of measurements were performed for each value of measured current.

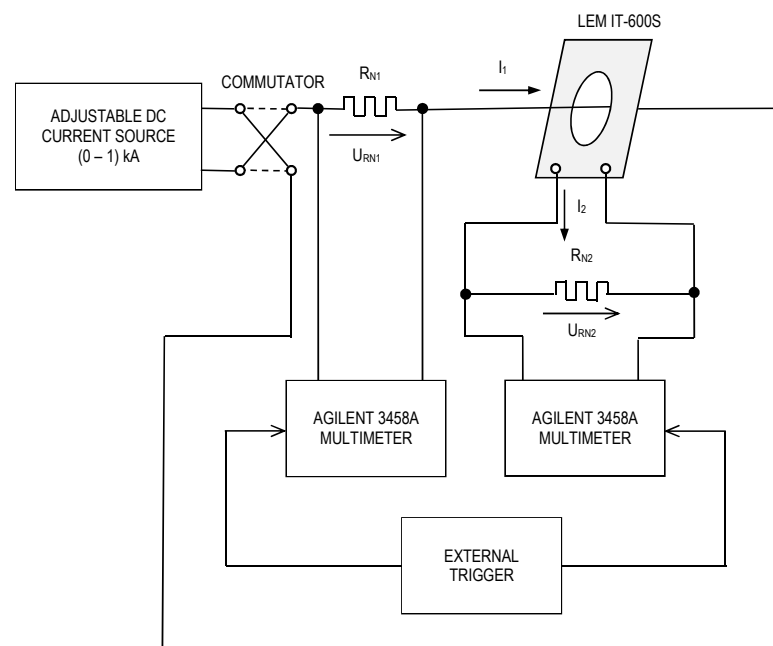

Fig. 1. Measurement set-up



Fig. 2. Workplace for LEM IT – 600S calibration

### 3. INRIM – Istituto Nazionale di Ricerca Metrologica (Italy)

#### 3.1 Measurement set-up

The measurement set-up (in Fig. 1 the schematic diagram and its implementation) is composed by three types of current ratio devices [1]:

- the DC current transformer (DCCT) under calibration, mounted on a copper bus bar ( $\varnothing 20$  mm) filling almost completely the DCCT primary through hole, and supplied by the Rohde&Schwartz Programmable Power Supply mod. HMP 4040 at  $\pm 15$  V nominal value, with relative accuracy  $< 1 \times 10^{-3}$ ,
- two different automated current range extender (EXT), depending on primary current  $I_P$ :  
for  $|I_P| \leq 100$  A the Measurement International mod. MI 6011B range extender, with nominal ratio 1/1000, and relative accuracy  $< 1 \times 10^{-7}$ ,  
for  $|I_P| \leq 2$  kA the Measurement International mod. MI 6012M range extender, with nominal ratio 1/1000, and relative accuracy  $< 2 \times 10^{-6}$ ,
- the DC current comparator ratio bridge (CC) Guidline mod. 9920;

two high current sources (S):

- for  $|I_P| \leq 100$  A the Measurement International mod. MI 6100A linear dc power supply, the current reversal is achieved with a switch internal to MI 6011B,
- for  $|I_P| \leq 1750$  A the Agilent mod. 6680 (two items in parallel), the Current reversal is achieved with a Measurement International mod. 6025 pneumatic switch;

and two multimeters:

- the Agilent mod. 3458A multimeter ( $A_C$ ), for measuring the CC compensation current  $I_C$ ,
- the Agilent mod. 3458A multimeter ( $A_D$ ), for monitoring the DCCT output current  $I_D$  by the voltage drop on a Tinsley mod. 1659  $1 \Omega$  standard resistor.

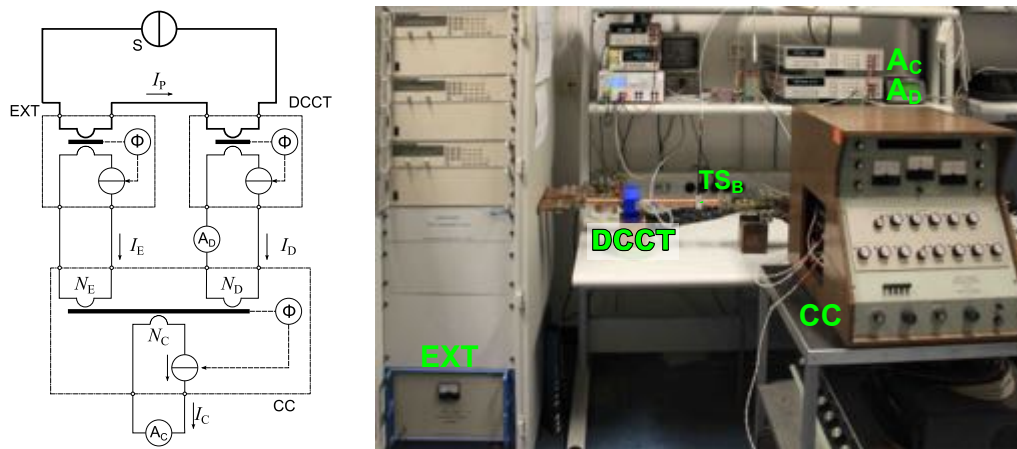

Fig. 1 - Schematic diagram (on the left) and the instrumental implementation (on the right) of measurement set-up.

The measurement system is in a temperature controlled laboratory ( $23 \text{ }^\circ\text{C} \pm 1 \text{ }^\circ\text{C}$ ), and three calibrated Pt100 sensors are used for monitoring simultaneously the ambient temperature ( $T_A$ ), the DCCT temperature ( $T_{SD}$ ), and the bus bar temperature ( $T_{SB}$ ). The sensors are connected to the scanner Fluke mod. 1529 Chub-E4 Standards Thermometer, and the readings are recorded as ASCII files on a PC.

A calibrated data logger Delta Ohm mod. HD206 is also used for recording the ambient humidity.

#### 3.2 Measurement method

As showed by schematic diagram in Fig. 1, the input windings of DCCT under calibration are connected in series to the EXT input windings and driven by the primary current  $I_P$ .

The DCCT and EXT output currents,  $I_D$  and  $I_E$ , are connected to two input windings of CC, each having  $N_D$  and  $N_E$  turns. Instead the CC compensation current  $I_C$  is connected to the CC winding with  $N_C$  turns, and is measured by the high-accuracy digital multimeter (DMM)  $A_C$ , while  $I_D$  is measured by the  $A_D$  DMM as voltage drop on the Tinsley  $1 \Omega$  standard resistor.

When operating properly, the CC balance equation is

$$N_E I_E + N_D I_D + N_C I_C = 0 \quad (1)$$

with  $I_D = G_D I_P$ , where  $G_D$  is the DCCT current gain, and  $I_E = G_E I_P$ , where  $G_E$  is the EXT current gain.

When in all current ratio devices, core fluxes are drawn to zero by their automated controls, the balance (1) gives the DCCT current gain, as

$$G_D = \frac{N_C I_C}{N_D I_P} - \frac{N_E}{N_D} G_E \tag{2}$$

To compensate the DCCT dc offsets,  $I_C$  in (2) becomes  $\Delta I_C = I_C - I_{C0}$ , where  $I_C$  is the reading taken at the nominal  $I_P$  of interest, and  $I_{C0}$  is the reading with  $I_P = 0$ , while to take in account the CC ratio errors, the current ratios  $n_{CD}$  and  $n_{ED}$  substitute the  $N_C/N_D$  and  $N_E/N_D$  corresponding nominal turn ratios, and (2) becomes

$$G_D = n_{CD} \frac{\Delta I_C}{I_P} - n_{ED} G_E \tag{3}$$

The relation with the measurand defined by eq. (1) of the protocol [2] is

$$G_D \equiv R = \frac{I_S - I_{\text{off}}}{I_P} \tag{4}$$

where  $I_P$  is the input current flowing in the travelling standard (the primary current),  $I_S$  its output current (the secondary current  $I_D$ ), and  $I_{\text{off}}$  its output current when  $I_P = 0$ .

As requested by comparison protocol, the  $G_D$  is measured for positive ( $+I_P$ ), negative ( $-I_P$ ) and zero value ( $I_{P0}$ ) of  $I_P$ , and is obtained with repeated measurements of the continuous sequence  $I_{P0}, +I_P, I_{P0}, -I_P, I_{P0}$ , where the reading  $I_C$  is continuously recorded as sequence

$$I'_C(I_{P0}), I_C(+I_P), I''_C(I_{P0}), I_C(-I_P), I'''_C(I_{P0}) \tag{5}$$

where each sequence takes about 10-15 minutes, depending on the  $I_P$  value.

The quantity  $\Delta I_C$  of (3) is then obtained from the time average  $\overline{I_C}(I_P)$  as

$$\begin{aligned} \Delta I_C(+I_P) &= \overline{I_C}(+I_P) - \left( \frac{\overline{I'_C}(I_{P0}) + \overline{I''_C}(I_{P0})}{2} \right) \\ \Delta I_C(-I_P) &= \overline{I_C}(-I_P) - \left( \frac{\overline{I''_C}(I_{P0}) + \overline{I'''_C}(I_{P0})}{2} \right) \end{aligned} \tag{6}$$

For each  $\Delta I_C$  the absolute and relative errors of  $G_D$  are evaluated.

After each turning on the measurement system is set at  $I_P = +I_P$  for a warming-up period of  $\sim 1$  h, to reduce the temperature effects on  $I'_C(I_{P0})$  in the first measurement sequence.

To avoid the automatic shutdown of DCCT, for  $|I_P| \geq 100$  A, the transition among the different values of  $I_P$  are done slowly, and however the evaluations of  $\overline{I_C}(I_P)$  always exclude the measurements acquired during the transient time between two value of  $I_P$ .

### 3.3 Measurement traceability

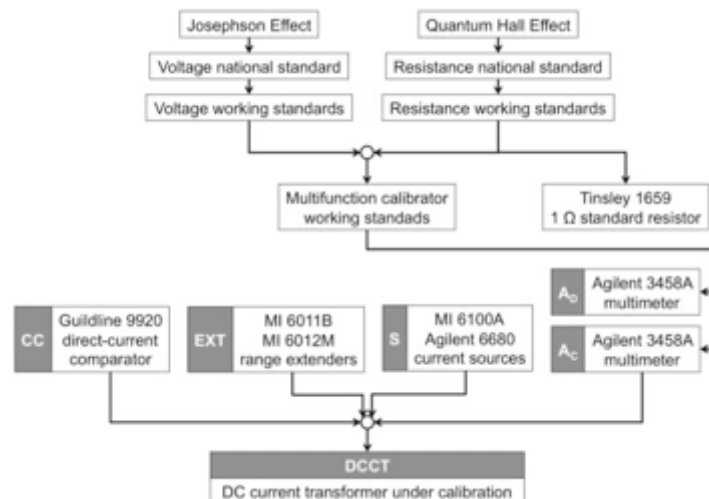

Fig. 2 – Traceability chain for calibration of DC current transformers

### 3.4 References

- [1] L. Callegaro, C. Cassiago, E. Gasparotto, “On the Calibration of Direct-Current Current Transformers (DCCT)”, *IEEE Trans. Instrum. Meas.*, vol. 64, no. 3, pp 723-727, Mar. 2015
- [2] C.Cassiago, A. Mortara, “Supplementary Comparison EURAMET.EM-S35 - Comparison of High-Current Ratio Standard”, *Technical Protocol*, pp 1-15, 2012

## 4. LCOE – Laboratorio Central Oficial de Electrotecnia (Spain)

### 4.1 Measurement set-up

Measurement set up consists of an electronic dc current source in series with the travelling current transducer standard and the LCOE standard resistor used to measure primary current. Between the current transducer and the standard LCOE resistor an special switch is placed in order to change the polarity only in the standard resistor, but not in the current transducer. In this way, each R+ and R- ratios can be measured averaging both current polarities voltage readings in the standard resistor.

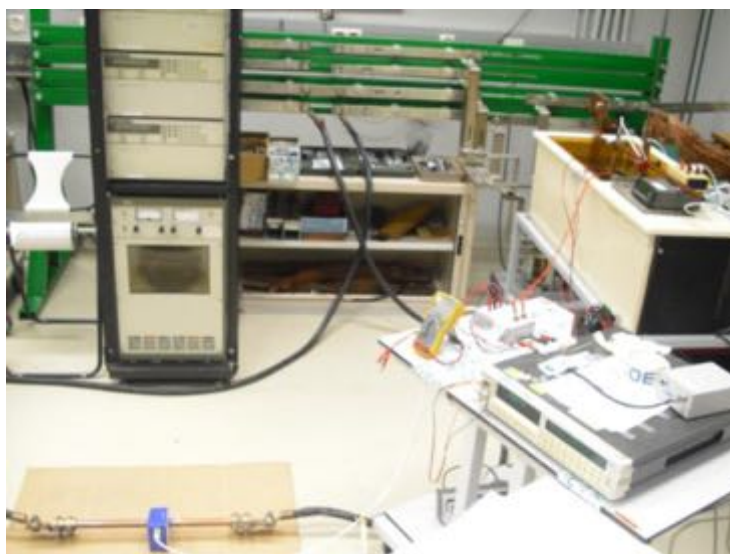

Figure 1. General measurement set up.

The travelling current transducer standard is connected to the output of the dc source by means of two cables and one bus-bar rod. The diameter of the rod is chosen in order to fit perfectly in the hole, so that centering error and uncertainty due to this effect is very small.

Temperature of the rod is measured by means of a thermocouple resulting in the following values an range of variation:

Current	Rod temperature
90 A	$23,6 \pm 0,5^{\circ}\text{C}$
300 A	$24,9 \pm 0,5^{\circ}\text{C}$
600 A	$29,1 \pm 0,5^{\circ}\text{C}$



Figure 2. Bus-bar rod and temperature measurement of the rod.

Standard resistor,  $R_p$ , used to measure primary current is inside an stirred oil bath in order to maintain its temperature in  $23^\circ\text{C} \pm 0,1^\circ\text{C}$ . When the primary current is 600 A two equal standard resistors connected in parallel are used. Secondary current is measured using 1 ohm standard resistor,  $R_s$ , immersed in the same stirred oil bath.

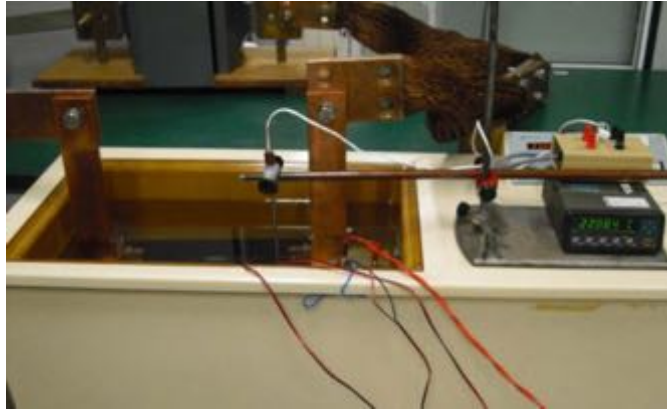

Figure 3. Stirred oil bath used for standard resistors.

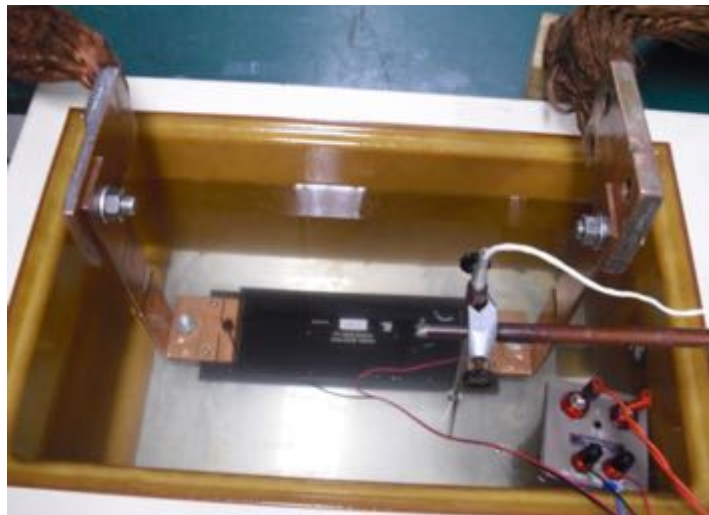

Figure 4. High current 1mohm standard resistor used for 90 A and 300 A.

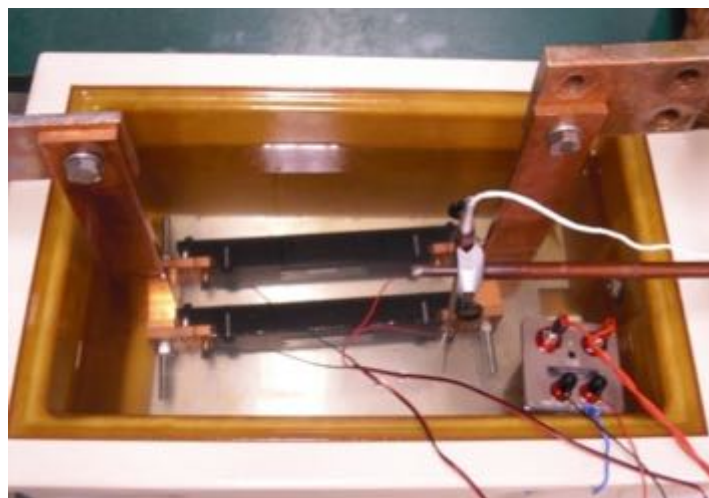

Figure 5. Two equal high current standard resistors of 1mohm connected in parallel for 600 A, inside the stirred oil bath, together with 1 ohm resistor connected to the current transducer output.

In order to change current polarity very fast, and almost cancel thermoelectric parasitic voltages in  $R_p$ , the following special 2000 A switch is used.

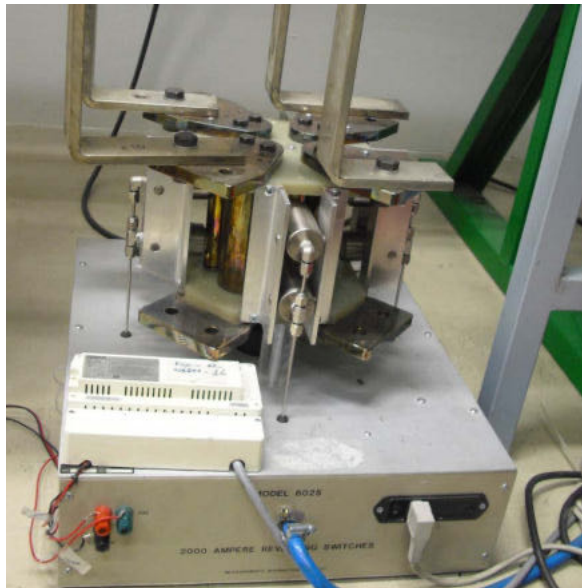

Figure 6. High current reversal switch.

## 4.2 Traceability scheme

The standard resistors and digital voltmeter used for the comparison are internally calibrated at LCOE.

Traceability for resistance is obtained by means of the 10 Ohm Thomas standard resistor calibrated at CEM, and traceability for dc voltage is obtained by means of the solid state dc voltage references of LCOE calibrated at CEM by means of the Josephson effect. CEM is the NMI of Spain.

LCOE is the DI in Spain for high voltages quantities. High current is not presently included in the CMC capabilities of LCOE as DI.

## 4.3 Measurement procedure

Measurement procedure consists in connecting in series the current bus-bar transducer with LCOE standard resistor, in such a way that the same current passes through the standard resistor and the bus-bar. The output current of the transducer is measured by means of the voltage drop in 1 Ohm standard resistor by means of a high resolution digital voltmeter.

Both voltage readings (voltage drop in the standard high current resistor,  $R_p$ , and voltage drop in the 1 Ohm resistor,  $R_s$ ) are recorded using the same voltmeter and a low thermoelectric switch. In addition, both readings are recorded using the same voltmeter range, in order to profit of its excellent linearity.

For each ratio polarity,  $R_+$  and  $R_-$ , and each current point, the following sequence to record voltage readings is used.

### **For 90 A and 300 A.**

a) Determination of ratio value for positive polarity,  $R_+$

1. Voltage offset readings  $V_{off}$ , in  $R_s$  are recorded, with current source off.

2. Current source of positive polarity is applied to the circuit.
3. Voltage readings of the primary current,  $V_{p(+)}$  by means of voltage drop in  $R_p$ .
4. Voltage readings of the output of current transducer,  $V_{s(+)}$  by means of voltage drop in  $R_s$ .
5. Change of current polarity in  $R_p$ , but not in the bus-bar rod.
6. Voltage readings of the primary current,  $V_{p(-)}$  by means of voltage drop in  $R_p$ .
7. Voltage readings of the output of current transducer,  $V_{s(-)}$  by means of voltage drop in  $R_s$ .
8. The sequence is repeated 10 times.

b) Determination of ratio value for positive polarity, R-,  
The same sequence is used but changing polarity in step 2.

#### **For 600 A**

Two equal standard high current resistors,  $R_{pa}$ ,  $R_{pb}$  are connected in parallel, so that the following sequence to register voltage readings is used.

a) Determination of ratio value for positive polarity, R+

1. Voltage offset readings,  $V_{off}$ , in  $R_s$  are recorded, with current source off.
2. Current source of positive polarity is applied to the circuit.
3. Voltage readings of the partial primary current are recorded,  $V_{pa(+)}$  and  $V_{pb(+)}$  by means of voltage drop in  $R_{pa}$  and  $R_{pb}$ .
4. Voltage readings of the output of current transducer,  $V_{s(+)}$  by means of voltage drop in  $R_s$ .
5. Change of current polarity in  $R_{pa}$  and  $R_{pb}$ , but not in the bus-bar rod.
6. Voltage readings of the partial primary current are recorded,  $V_{pa(-)}$  and  $V_{pb(-)}$  by means of voltage drop in  $R_{pa}$  and  $R_{pb}$ .
7. Voltage readings of the output of current transducer,  $V_{s(-)}$  by means of voltage drop in  $R_s$ .
8. The sequence is repeated 10 times.

b) Determination of ratio value for positive polarity, R-,  
The same sequence is used but changing polarity in step 2.

## 5. LNE – Laboratoire national de métrologie et d’essais (France)

### 5.1 Measurement set-up, procedure and traceability at 90 A

The secondary to primary current ratio of the travelling standard is measured at 90 A by means of two standard resistors as illustrated in *Figure 1*. The values of the standard resistors are selected to form the desired ratio.

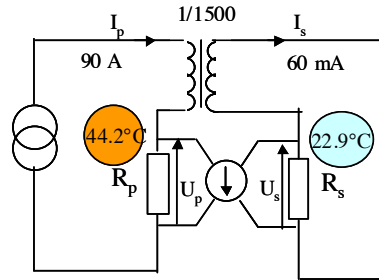

Figure 1 Measuring principle of the current ratio at 90 A

The nanovoltmètre measures the voltage difference as described in the following equation:

$$\Delta U = R_s I_s - R_p I_p \quad (\text{Équation 2})$$

The value of the current ratio is given by the equation:

$$R = \frac{R_p}{R_s} + \frac{\Delta U}{R_s I_p} \quad (\text{Équation 3})$$

with:

$R_p$  - Standard resistance on the side of the primary current

$R_s$  - Standard resistance on the side of the secondary current

$\Delta U$  - Measured voltage difference

$I_p$  - Primary current.

#### Measurement procedure

Both standard resistors,  $R_p$ , respectively  $R_s$ , were characterized under the same conditions as required for the travelling standard calibration.

The calibration procedure starts by measuring the values of both resistors using the automated primary resistance bridge type Measurement International (MI) 6010 at the same current level as necessary for the comparison measurements (90 A for  $R_p$ , 60 mA for  $R_s$ ). The necessary time for the resistances to reach the normal usage conditions is respected in order to reduce the influence of preliminary measurements on the values of standard resistors.

The second step of the calibration process consists in adjusting the primary current at 90 A. Once the circuit stability is reached, the nanovoltmeter readout is kept. The current is reversed and the measurement for the other polarity is performed.

The necessary time for the resistances to reach again the normal usage conditions is respected and, then, the calibration procedure ends by measuring again the values of both standard resistors.

The value of the current ratio is given by the (Equation 3) where :

$R_p$  is the mean value of the standard resistance on the side of the primary current measured before and after its use;

$R_s$  is the mean value of the standard resistance on the side of the secondary current measured before and after its use;

$\Delta U$  is the nanovoltmeter readout;

$I_p = \frac{U_{I_p}}{R_{I_p}}$  is the value of the primary current given by the ratio of the voltage measured by a standard digital multimeter (DMM) across a calibrated shunt.

The same procedure was applied several days leading to the results presented in the section 3.

#### Traceability

The measured current ratio (Equation 3) is traceable to the SI through the calibration of the resistors, shunt and digital voltmeters with reference to the French national standards.

Used standards:

$R_p$  - Standard resistance on the side of the primary current (type SAS 288, SN° 1019543);

$R_s$  - Standard resistance on the side of the secondary current (type VPR221Z(Z-Foil), SN° 1020713);

$\Delta U$  - Measured voltage difference (NanoVolt/Micro-Ohm Meter type Agilent 34420A, SN° US36002129);

$I_p$  - Primary current given by the ratio of the voltage measured by a standard DMM of type Wavetek 1281(SN°31324) across a calibrated shunt.

## 5.2 Measurement set-up, procedure and traceability at 300 A and 600 A

The secondary to primary current ratio of the travelling standard is measured at 300 A and 600 A by means of a high precision DC current transformer and two standard resistors as illustrated in Figure 2.

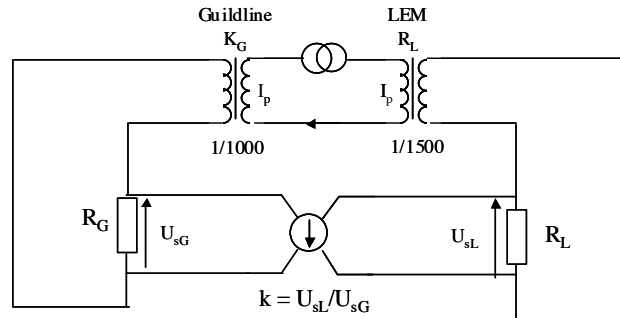

Figure 2 Measuring principle of the current ratio at 300 A and 600 A

The digital voltmeter measures the voltage ratio as described by the following equation:

$$k = \frac{R_L I_{sL}}{R_G I_{sG}} \quad (\text{Équation 4})$$

The value of the current ratio of the travelling standard is given by the equation:

$$R = \frac{R_G}{R_L} \cdot \frac{k}{K_G} \quad (\text{Équation 5})$$

with :

$R_G$  - Standard resistance on the side of the secondary current of Guildline DC current transformer

$R_L$  - Standard resistance on the side of the secondary current of LEM zero flux current transformer

$k$  - Measured voltage ratio

$K_G$  - Current ratio of the Guildline DC current transformer.

### Measurement procedure

The calibration procedure consists in adjusting the primary current at the necessary level (300 A, respectively 600 A). The necessary time to reach the circuit stability is respected.

The readout of the digital multimeter (DMM) representing the voltage ratio is kept.

The current is reversed and the measurement for the other polarity is performed.

For a given level of current, several readouts are monitored at regular time intervals (every 10 to 15 minutes) between polarities.

Both standard resistors,  $R_G$ , respectively  $R_L$ , were characterized under the same conditions as required for the travelling standard calibration by means of the automated primary resistance bridge type Measurement International (MI) 6010.

The value of the current ratio is given by the (Equation 5) where:

$R_G$  - is the value of the standard resistance on the side of the secondary current of Guildline DC current transformer

$R_L$  - is the value of the standard resistance on the side of the secondary current of LEM zero flux current transformer

$k$  - is the mean value of the measured voltage ratios for one polarity

$K_G$  - is the current ratio of the Guildline DC current transformer.

### Traceability

The measured current ratio is traceable to the SI through the calibration of the resistors, digital multimeter (mode ratio) and DC current transformer with reference to the French national standards.

## Used standards:

$R_G$  - Standard resistance on the side of the secondary current of Guildline DC current transformer (type SC 1, SN° 1016771)

$R_L$  - Standard resistance on the side of the secondary current of LEM zero flux current transformer (type SC 2, SN° 1016773)

$k$  - Measured voltage ratio (reference multimeter type Fluke 8508A, SN° 1008024)

$K_G$  - Current ratio of the Guildline DC current transformer (type Range Extender 9921, SN° 39.111)

## 6. METAS – Federal Institute of Metrology METAS (Switzerland)

### 6.1 Measurement set-up and procedure

**Loop 1:** The unit under test was connected in the current loop of a stable current source together with a reference current comparator. The output current of the UUT was measured with a high resolution voltmeter (input impedance > 10 GΩ) and a reference resistor (1 Ω). The current ratio  $R$  of the comparator is defined as follows:

$$R = \frac{I_m - I_{off}}{I}$$

Where  $I$  is the primary current and  $I_m$  the secondary current.  $I_{off}$  is the offset correction, including the offset current of the comparator, the offset voltage of the used multimeters and of the thermal voltages in the connections. The offset current was evaluated before and after the measurements by opening the measurement loop and its time-dependence was taken into account in the evaluation of the results.

**Loop 2:** Method 1

The unit under test (UUT) was connected in the current loop of a stable current source together with a reference current comparator. The output current of the UUT was measured with a high resolution voltmeter (input impedance > 10 GΩ) and a reference burden resistor  $R_{bx}$  (1 Ω). The current ratio  $R$  of the comparator is defined as follows:

$$R = \frac{I_m - I_{off}}{I}$$

Where  $I$  is the primary current and  $I_m$  the secondary current.  $I_{off}$  is the offset correction, including the offset current of the comparator, the offset voltage of the used voltmeters and of the thermal voltages in the connections. The offset current was evaluated before and after the measurements by opening the primary current loop and its time-dependence was taken into account in the evaluation of the results.

Method 2

$R_{av}$ , defined as the average of  $R$  over positive and negative primary currents of the same magnitude, was measured using an alternative method noting that the UUT, with its burden, is the functional equivalent of a low-resistance, high-current shunt of value  $R_{av} \cdot R_{bx}$ . It was accordingly measured in the same way as a shunt using a commercial high-quality calibrated current comparator bridge and range extender assembly.  $R_{av}$  measured in this way was then used to correct voltmeter gain errors affecting the results of method 1.

### 6.2 Measurement traceability

**Loop 1:**

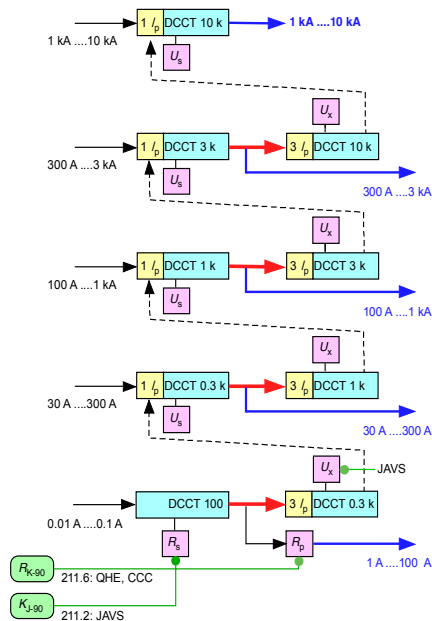

**Loop 2:**

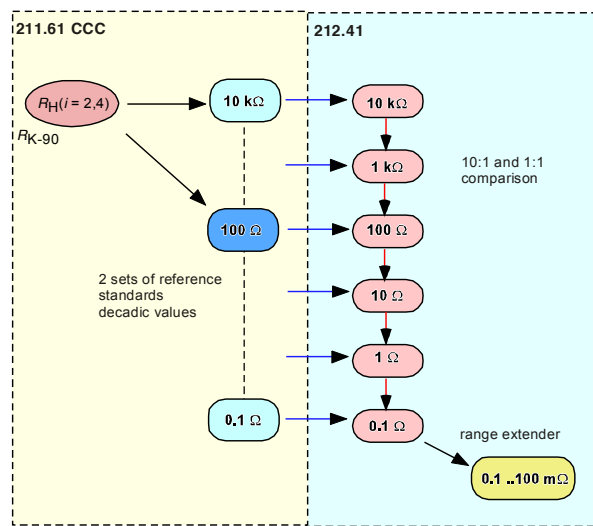
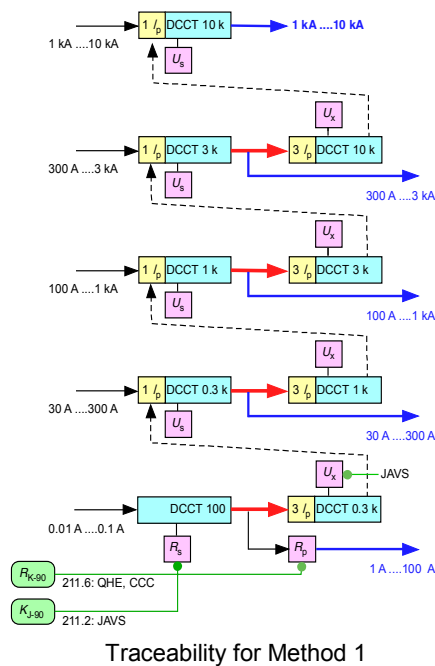

**6.3 Measurement conditions**

**Loop 1:**

Ambient temperature:  $(23.3 \pm 0.5) ^\circ\text{C}$   
 Warm-up time before the measurement (with power supply connected): > 24 h.  
 The measurements were performed between May 7 and May 21, 2013.  
 Temperature was also measured on the primary current bar, as close as possible to the measuring head. Its values are reported in the results table.  
 Positive and negative voltage supplies were measured in open primary conditions before each measurement sequence. Their values are reported in the results table as well.

**Loop 2:**

Ambient temperature:  $(23.3 \pm 0.5) ^\circ\text{C}$   
 Warm-up time before the measurement (with power supply connected): > 24 h.  
 The measurements were performed between September 26 and December 8, 2014.  
 Temperature was also measured on the primary current bar, as close as possible to the measuring head. Its values are reported in the results table.  
 Positive and negative voltage supplies were measured in open primary conditions before each measurement sequence. Their values are reported in the results table as well.  
 The primary current in the UUT was distributed evenly and return currents were routed symmetrically around the UUT.

## 7. MIKES – Centre for Metrology and Accreditation (Finland)

### 7.1 Calibration method

#### The basic setup and calculations

In the technical protocol of the EURAMET.EM-S35 comparison the current ratio of the travelling standard was defined as

$$R = \frac{I_S - I_{off}}{I_P}, \quad (1)$$

where  $I_P$  is the input current (primary current) flowing through the travelling standard and  $I_S$  the output current of the travelling standard.  $I_{off}$  is the output current of the travelling standard when the input current is zero. The values of positive current  $R_+$ , negative current  $R_-$  and the average  $R_M$  of  $R_+$  and  $R_-$  were measured.

The average was defined simply as

$$R_M = \frac{R_+ + R_-}{2}. \quad (2)$$

The current ratio of the travelling standard was calibrated by measuring the primary and secondary currents of the setup shown in figure 1. The multimeters were controlled by custom software, and they were triggered simultaneously through GPIB bus. The currents were calculated by measuring the voltages  $U_S$  and  $U_P$  over the resistors  $R_S$  and  $R_P$  shown in the figure.

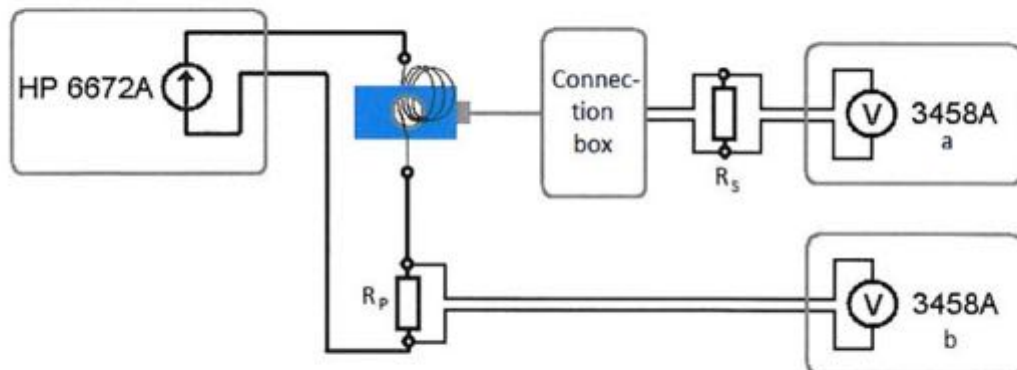

Figure 1: A typical measurement setup.

The following formula was used to calculate  $R_+$  and  $R_-$ :

$$R_{\pm} = \frac{I_S - I_{off}}{I_P} = \frac{I_S - I_{Soff}}{I_P - I_{Poff}} = \frac{U_S / R_S - U_{S-off} / R_S}{NU_P / R_P - NU_{P-off} / R_P} \cdot r \cdot c. \quad (3)$$

$I_{Soff}$  is the secondary current when the primary loop is opened and the current is zero and the  $I_{Poff}$  is the primary current in the same situation.  $R_S$  and  $R_P$  are calibration values of the resistors.  $U_{Soff}$  is the voltage measured by the DMM over the  $R_S$  etc.  $N$  is the number of turns wound through and around the travelling standard.

Drift of the current sources are large and they are seen as large drifts in voltages. However, simultaneous triggering of the two multimeters helps to cancel the influence of this drift. Statistical uncertainties calculated from the variations of individual voltages would not represent the uncertainty of the voltage ratio measurement. Thus the uncertainties associated to voltages ( $U_S$  etc.) include only the calibration uncertainties of the DMMs. (And actually only the gain uncertainties of the calibrations because the offset errors are eliminated in the formula 3.) Term  $r$  has value of 1 and it is added to represent the statistical uncertainty of the voltage ratio. Term  $c$  has value of 1 and it represents the reproducibility of measurements.

#### The devices

The devices used in the measurements are shortly described in the following paragraphs.

##### Sources

Three different current sources were used in the measurements.

### Magna Power TSD5-900/380

Before the comparison the Magna Power TSD5-900/380 power supply, which can source 900 A and 5 V, was planned to use in the measurements because it is the only DC current source in MIKES that can source required 600 A directly.

The source is unipolar so the primary current connectors needed to be unscrewed and interchanged when negative current was needed.

Traceability of the high DC currents up to 100 A is based on 10 m $\Omega$  and 1 m $\Omega$  resistors calibrated by using Measurements International resistance bridge and current range extender. Calibration of currents from 100 A to 600 A is based on MIKES ZFCT with multiple turns. This means that calibrating the travelling standard at 300 A and 600 A without using multiple turns is possible only by sourcing the current from the Magna Power source and putting the travelling standard and a calibrated MIKES ZFCT in the same loop.

A couple of test measurements were made by using this setup, but it was not used in the actual comparison measurements mainly because it is more reasonable to calibrate the travelling standard directly by using the < 100 A sources and multiple turns. Creating the traceability chain via the MIKES ZFCT would only add one extra step to the traceability chain. (See the Fig. 2 for traceability.)

### HP 6672A

HP 6672A (sn. US36390470) can source 100 A and 20 V and it was used in all the calibration points 90 A, 300 A and 600 A. Multiple turns, 3 or 8, wound through and around the travelling standard were used to generate currents over 100 A. The current of the HP 6672A typically drifted tens of ppms during a set of measurements (maximum 2 hours), but drift at this level was acceptable.

Also this source is unipolar so the primary current connectors needed to be unscrewed and interchanged when negative current was needed.

### Fluke 5720A and Fluke 5220A

The Fluke 5720 Calibrator was used to source 0 V to  $\pm 20$  V and the Fluke 5220A transconductance amplifier was used to convert the voltage into 0 A to  $\pm 20$  A current. 30 turns of relatively thin cable was used to create the required current values for the travelling standard. Current of this source typically drifted less than 10 ppm during a set of measurements.

### Resistors

Two different resistors  $R_p$  in the primary current and one resistor  $R_s$  on the secondary current were used in the measurements.

### Cambridge 10 m $\Omega$

In some of the measurements the primary current of the travelling standard was measured as a voltage drop over the 10 m $\Omega$  resistor Cambridge 150A (sn. L-201374, shown in fig. L1 of Appendix 1). The device has a current dependency of less than 5 ppm from 10 A to 40 A, and it has calibration uncertainty of 2.1 ppm ( $k=2$ ). From 40 A to 100 A the value changes almost 100 ppm due to heating and the uncertainties are significantly higher. The calibration history over several years verifies also a good long term stability. This resistor was the optimal choice especially for the 3 A to 20 A currents generated by the Fluke 5220A source.

### Guildline 9230A 1 m $\Omega$

In some of the measurements the primary current of the travelling standard was measured as a voltage drop over the 1 m $\Omega$  resistor Guildline 9230A-300-0.001 (sn. 68234). The device has a current dependency of about 10 ppm from 50 A to 100 A, and it has calibration uncertainty of 4.05 ppm ( $k=2$ ). It has an active air cooling by two fans. The calibration history over several years verifies also a good long term stability. This resistor was the optimal choice especially for the 20 A to 100 A currents generated by the HP 6672A source.

### MIKES 1 $\Omega$ shunt

The secondary current of the travelling standard was measured as a voltage drop over the 1  $\Omega$  current shunt sn. TM1003 which is a fan cooled shunt constructed in MIKES. It has less than 1 ppm current dependency in the range from 100 mA to 1 A, and those results can be applied to the 60 mA - 400 mA range needed in this comparison.

### Cables

The travelling standard has a hole with 1 inch diameter for the primary inductor. The cross-sectional area available for the actual copper conductor is in practice much less than the full 500 mm<sup>2</sup> of the 1 inch hole because the typically large connectors in the end of the cables and the isolation material around the copper wire must also fit through the hole. For example 10 mm<sup>2</sup> conductor could be wound only 8 times through the ZFCT hole until there were no more space to push the connector of the cable through the hole.

1.8 mm<sup>2</sup> conductor was the largest available to fit for 30 turns setup and 70 mm<sup>2</sup> for single turn setup. 100 mm<sup>2</sup> cables already had connectors wider than 1 inch. Bare copper bars used in some other MIKES's high current setups were also too large to fit the hole of the ZFCT.

The limited conductor area caused some heating problems. The comparison protocol stated that the temperature measured on the surface of the primary conductor should not exceed 50 °C. In the 600 A tests done without the ZFCT showed that without cooling the steady state temperature of the 70 mm<sup>2</sup> conductor could heat up close to 100 °C within few minutes.

The alternatives to stay below 50 °C were either to use some active cooling of the cable surface or make only short measurements and always shut off the current when the temperature approaches 50 °C. In the beginning the alternative of the short measurements were used. Later it was discovered that a simple and effective air cooling was possible to create by putting a mouth of an ordinary vacuum cleaner close to the ZFCT hole and suck the 23 °C ambient air through the hole. This way the steady state conductor surface temperature of 600 A measurements stayed well below 40 °C.

#### DMMs

Two HP 3458A DMMs were used to measure voltage drops over resistors  $R_p$  and  $R_s$ . The use of the DMMs is described in paragraph 2.1, and their traceability in paragraph 3.

#### Temperature scanner

Agilent 34970A temperature scanner with 3 PT500 sensors was used to monitor the ambient temperature and the temperature of the primary connector surface.

#### Power supply

A nonadjustable  $\pm 15$  V laboratory power supply was used to supply the travelling ZFCT. Deviation of -15 V from nominal was large but still well within the range required in the protocol. The continuous monitoring of the supply voltages would have required two extra DMMs. Instead of 4 DMM setup some measurements were made just for supply voltage monitoring. On these measurements the two HP 3458A DMMs were measuring the supply voltages instead of the voltage drops over reference resistors.

The levels of the supply voltages were clearly dependent on the current flowing through the ZFCT so these measurements were made at all calibration currents -600 A, -300 A, -90 A, 0 A, +90 A, +300 A and +600 A.

Polarity of the current has a clear effect: -600 A made the absolute value of the positive supply to drop 0.09 V (from 15.07 V at zero test current to 14.98 V) and absolute value of the negative supply to rise 0.03 V (from -15.42 V to -15.45 V). Feeding +600 A made the positive supply to rise 0.01 V (from 15.07 V to 15.08 V) and negative supply to drop 0.04 V (from -15.42 V to -15.38 V).

It is not known whether it is really correct to generalize these results to cover all individual measurements, but continuous recording of the supply voltages would have required a setup of 4 DMMs which was considered too difficult to arrange.

#### Software

Self-made software was used to record the voltages of the DMMs. The most important feature of the software is that the DMMs are triggered simultaneously to eliminate the errors caused by the current source drifts and variations. The temperatures were measured by another software.

The current sources were operated manually.

## 7.2 Some measurement practices

### Structure of the measurement sequences

The measurements were made by alternating positive, negative and zero current periods. Zero current was always measured when the primary current loop was opened to avoid the offset of the sources. In some of the measurements the current was on for example 30 min so that all the significant warming of the sources, cables and resistors was over and the measured voltages were at steady state. Some of the measurements were much shorter so that the current was on just for 1 to 5 min because the steady state of the voltage ratio was reached much faster than the steady state of voltages.

Typical measurement sequence for the steady state measurements was as following:

1. positive current measured for 10 to 30 minutes until enough steady state data is recorded
2. one of the current source cable disconnected and zero current measured for 10 to 30 minutes
3. current source cables reversed and negative current measured for 10 to 30 minutes
4. DMMs interchanged to see possible effect of DMM calibration errors
5. negative current measured for 10 to 30 minutes
6. zero current measured for 10 to 30 minutes
7. positive current measured for 10 to 30 minutes

Some of these sequences included a calibration of only one current level, in other words for example +90 A, 0 A and -90 A. Sometimes two or three current levels were measured in one sequence, in other words for example +600 A, +300 A, +90 A, 0 A, -90 A, -300 A, -600 A, DMM interchange, -600 A, -300 A... +600 A etc. Here the currents have common zero current phase for zero correction.

In the previous sequence the change of the current level is done 14 times. The 10 to 30 min wait time after changing the current was the most time consuming part of the measurement so the more time saving sequence was to do the DMM interchange 7 times instead of one, i.e. in the middle of every current level: +600 A, DMM interchange, +600 A continues, +300 A, DMM interchange, +300 A continues, etc. In this sequence there is only 7 times of 10 to 30 min wait time after changing the current. After DMM interchange no wait time is needed because current can be on during the DMM interchange and the setup stays in steady state.

Sequences where negative currents were measured before positive currents were also used.

#### **Symmetry and number of turns of the primary conductor**

In multiple turn primary conductor measurements the effect of the symmetry of the coil around the ZFCT was tested. At least in some measurements it seemed that with a more symmetric coil the offsets were smaller and the results closer to the nominal value. After this finding the rest of the measurements were done with at least somewhat symmetrical coil like the one in figure L1 in Appendix 1. More ideal symmetry was difficult to implement with thick semi rigid cables without any support structures.

#### **Position of the travelling standard**

Most of the measurements were done with the ZFCT hole placed on the vertical axis and the white side of the ZFCT upwards (see fig. L1 in Appendix 1). Some measurements were done the hole along the horizontal axis but this did not seem to have any measurable systematic effect on the results.

#### **Zero correction**

Voltages measured from zero current periods also have some transients before reaching the steady state. Using only first point, last points or all zero period data seemed to have an effect that changed the values of  $R_1$  and  $R_2$  from less than ppm to over 10 ppm. (The average value  $R_M$  does not change because the offset is cancelled when it is calculated.)

Idea of zero correction is to remove the effect of thermal voltages, DMM offsets and other possible offsets present during the actual measurement period when the test current is on. The temperature of the setup must be the same in the actual measurement and when zeroes are measured. Otherwise the thermal voltages would be different from the ones present during the actual measurement. Thus only the beginning of zero data when the setup is still warm is used. It was decided to use the 10 first points which corresponds first 20 seconds. This is a compromise between having insufficient number of samples in too short measurement and cooling of the setup in too long measurement. Because the time constant of cooling seemed to be in the range of 10 minutes there should not be too much cooling during 20 s.

In some sequences described in 2.3.1, a common zero is used for several currents. In these cases the temperature conditions of the zero period obviously does not represent the conditions of all these currents. These results are abandoned if they seem to have unusually large offset (over 2 standard deviations from all offsets on that current).

In general the offset, defined as  $(R_1 - R_2)/2$ , seems to be quite repeatable because the standard deviations of  $R_1$  and  $R_2$  results over the entire MIKES measurement period are typically not larger than the standard deviations of  $R_M$  results.

## **7.3 Measurement standards used in calibration and traceability**

### **The standards**

Digital multimeter HP 3458A, MIKES001031, certificate M-13E028.  
 Digital multimeter HP 3458A, MIKES003643, certificate M-13E025.  
 1  $\Omega$  resistor MIKES TM1003, MIKES000025, certificate M-13E201.  
 10 m $\Omega$  resistor Cambridge 150A (sn. L-201374), certificate M-13E075.  
 1 m $\Omega$  resistor Guildline 9230A-300-0.001 (sn. 68234), certificate M-13E171.

### **Traceability**

#### **Resistance**

Traceability of the resistance is based on MIKES quantum Hall standard and it is transferred to the resistors used in this comparison according to the figure 2.

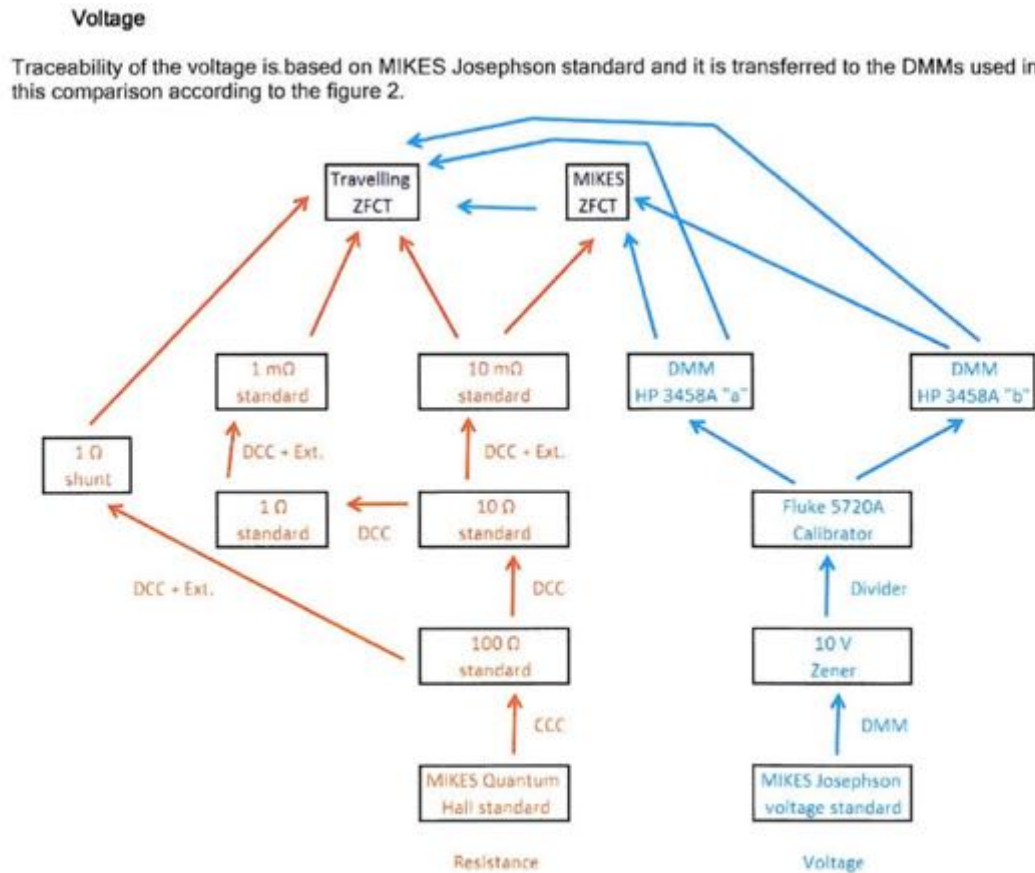

Figure 2: Traceability chain of resistance and voltage. In some cases the main transferring devices are also shown: CCC is cryogenic current comparator, DCC is a commercial resistance bridge, ext. is a commercial current range extender, DMM is a digital multimeter or nanovoltmeter and the divider is a reference voltage divider Fluke 752A.

### 7.4 Measurement conditions

The measurements were made in a temperature and humidity controlled laboratory. Air enters the lab through metal grids on the floor and the temperature of the incoming air was  $22.55\text{ °C} \pm 0.10\text{ °C}$  and the relative humidity was  $38.7\% \pm 0.2\%$  according to the sensors placed on the air pipe below the floor.

The travelling ZFCF was placed on the floor on top of the air pipe grid (see fig. L1 in Appendix 1) or in some cases close to it because there the temperature and humidity of the ambient air are most stable. (Only exceptions were the few measurements with the 900 A source because the cable (see fig. L3) was too short to reach the floor.) The ambient temperature measured by the temperature scanner and PT500 sensors (certificate M-12E121, calibration uncertainty  $0.02\text{ °C}$ ) was  $22.52\text{ °C} \pm 0.10\text{ °C}$ .

The temperatures measured from the primary conductor surface are reported separately for each calibration result in the appendix file "EURAMET.EM-S35\_report-MIKES".

### 7.1 Appendix 1

Some photos of the setup.



Figure L1: Some details of one of the measurement setups. On the left the 10 mΩ resistor, the voltage measurement wires going to the DMM are also visible. In the middle the travelling ZFCT with 8 loops of cable around it, the temperature sensor measuring on the surface of the cable from inside the ZFCT, a vacuum cleaner pipe coming from up. On the right the HP 100 A current source.

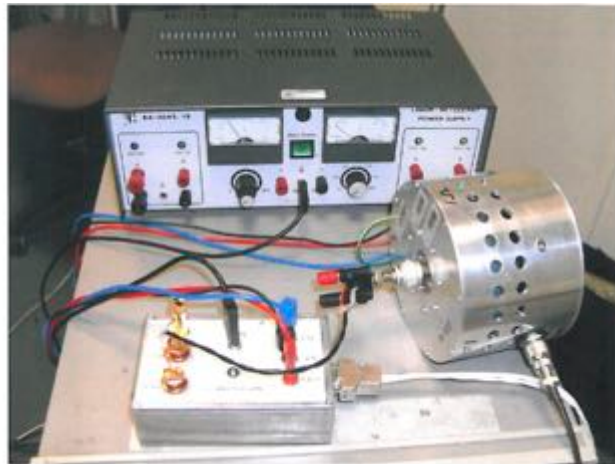

Figure L2: The  $\pm 15$  V power supply, the 1  $\Omega$  resistor and the connection box of the travelling ZFCT.



Figure L3: The MIKES ZFCT and the travelling ZFCT connected to the Magna Power (max. 900 A) source. Measurements were done at +90 A, +300 A and +500 A. This setup was not used for calculating the comparison values because the MIKES ZFCT is not yet characterized well enough to be used as a reference on this uncertainty level, but the results still seemed to be within 10 ppm from the actual comparison results

## 8. PTB – Physikalisch-Technische Bundesanstalt (Germany)

### 8.1 Measurement procedure and Traceability scheme

The measurements were made using a high current power supply consisting of a calibrator and a transconductance amplifier. The primary current was measured using a precision current transformer (Guildline range extender 9923) and a 10 Ω resistance standard. The output current of the travelling standard was measured using a 1 Ω and a 1.9 Ω resistance standard. The voltages were measured with a long-scale digital multimeter.

The measurements were run automatic using a METCAL(R) procedure. The measuring sequence was zero operate - +90 A operate - zero operate - -90 A operate - zero operate. The ground and guard connection is shown in the figure below.

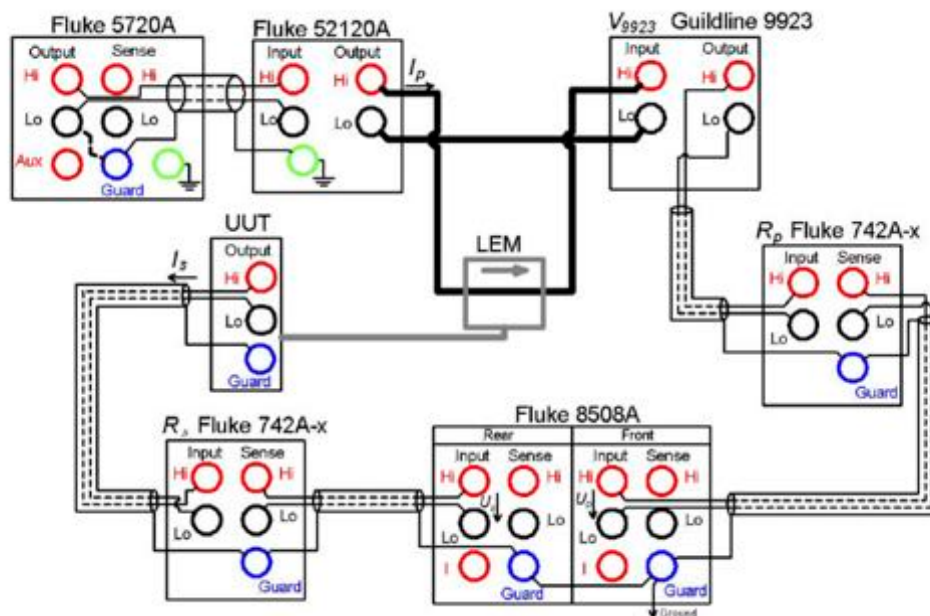

Fig. 1 connection scheme

All measurements are traceable to PTB's realisations of the unit of resistance, based on the Quantum Hall resistance standard, and the unit of voltage, based on the Josephson voltage standard.

### 8.2 Measurement set-up for the calibration of high current measuring instruments

The device under test and the reference current transformer are connected in series and thus measuring the same current. This is important as far as the offset current is concerned. Investigations show that the reference transformer has no offset, but the device under test (DUT) has. Also, the amplifier, when in zero operate function, has an offset current. Since the secondary resistors are different and also the nominal ratios, the additional offset current due to the non-zero current of the amplifier gives a different offset in the voltage measurement which is recorded.

The residual offset voltage of the DMM is estimated to have an upper limit of < 0.6 μV.

The value for  $R$  is determined by

$$R = \frac{I_S - I_{S0}}{I_P}$$

The ratio  $R$  is determined for both polarities of the current.

The current conductor was fed centered through the hole in the DUT, the return conductor was at least 1 m distance from the DUT. Small variations of the position of the conductor are included in the repeated type A uncertainty.

The measurement uncertainty includes a contribution for the short term instability of the standards.

All quantities are considered to be uncorrelated.

## 9. SIQ – Slovenian Institute of Quality and Metrology (Slovenia)

### 9.1 Reference standards

#### Zero Flux system

Zero flux measurement principle is based on obtaining the balance between the magnetic flux generated by the measured current in the primary winding of the system (wire containing the measured current) and the magnetic flux generated by the current in the secondary winding situated in the measuring head of the system. This balance is known as the condition of zero flux. Secondary current then flows through the standard stable burden resistor located inside the system and voltage drop across this resistor is amplified by means of a precision amplifier and output voltage from this amplifier is then measured as a proportional measure of the current being measured with the zero flux system. The basic equation for obtaining the measured current  $I_S$  from the measured voltage at the output of the zero-flux system is:

$$\text{Eq. 2-1: } I_S = M_{ZF} \cdot U_{ZF}$$

where

$M_{ZF}$  zero flux system current sensitivity given in A/V,

$U_{ZF}$  voltage measured at the output of the zero flux system.

Zero flux system current sensitivity is calibrated before each use so that burden resistor stability and offset does not influence the measurement and therefore lower uncertainties can be achieved. For the purpose of measuring the zero flux current sensitivity with lower DC currents auxiliary primary windings have been added to the measuring heads of the system for the purpose of generating the magnetic flux in primary winding of the system which simulates the measuring current.

The reference Zero Flux system is HITEC PP Zero Flux Current transformer STACC ST 06-3. (s.n.: H01AST017/M01AST017/UNR 4-4020).

#### Current source

As DC current source the universal calibrator Fluke 5720A (s.n.: 5215008) in combination with voltage driven trans-conductance amplifier Clarke-Hess 8100 (s.n.: 266) were used.

#### Multimeter HP 3458A

For reading the output voltage of Zero Flux two digital multimeters HP 3458A (s.n.: 2823A20702 and US28028518) were used. They are both periodically calibrated at SIQ according to internal procedures.

#### Resistor Fluke 742A-1

Output current of transducer under calibration was measured over the voltage drop on reference resistor Fluke 742A-1 (s.n.: 6655001) were used. The resistor is periodically calibrated at SIQ according to internal procedures.

### 9.2 Measurement procedure

#### Calibration of current sensitivity for 50 A zero flux measuring head

50 A measuring head of the Zero Flux system current sensitivity was calibrated by measuring the current through the auxiliary primary winding with the voltage drop method across calibrated standard laboratory resistor.

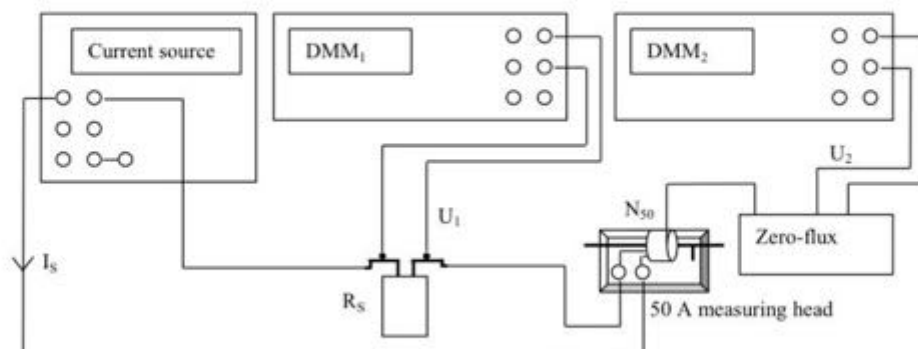

Figure 1: Calibration setup for calibration of 50 A measuring head current sensitivity

Equipment was connected as shown in figure above. First the offset reading at the output of the zero flux system for 50 A measuring head was minimized using the offset trimmer located at the front panel of the 50 A measuring head module. Then current source was adjusted for maximum reading at the DMM<sub>2</sub>, which is 10 V. Voltage readings from both DMM's were taken. At the end current source was turned off. After the measurement of the current sensitivity is finished, no additional offset adjustment shall be done, as this would affect the calibrated value of current sensitivity.

### Calibration of current transducer (UUC)

Calibration was carried out by serial connection of current transducer under calibration and zero flux system with stable current source. The primary current was measured with zero flux system. The output current from current transducer was measured over the voltage drop measurement on reference resistor.

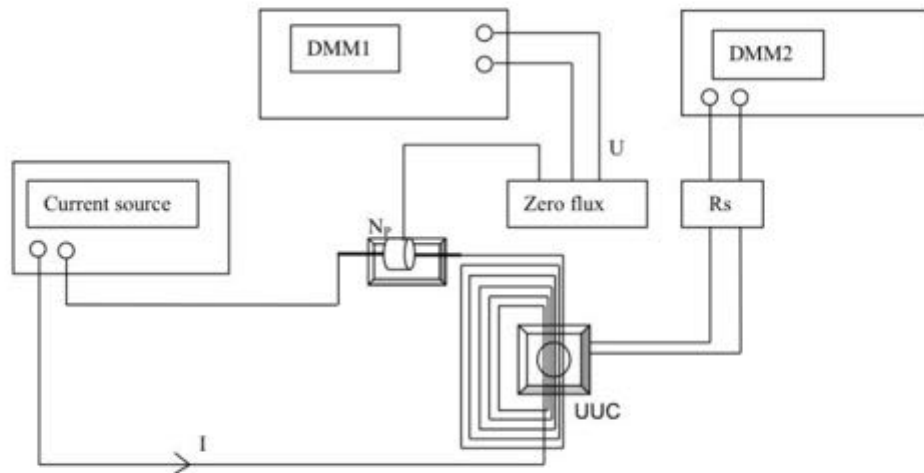

Figure 2: Calibration setup for calibration of current transducer

Equipment was connected as shown in figure above. Through the transducer under calibration 6 windings were wound. Each winding was made from 50 mm<sup>2</sup> copper rod and rods were connected together with copper wire with 25 mm<sup>2</sup> cross-section. Therefore 6 times higher current than generated with current source was measured.

DMM was connected to the voltage output from zero flux system. Then current source was adjusted for nominal setting at which DUT is being calibrated. After that the readings of the voltages from both DMMs were taken.

Primary current was calculated as:

$$\text{En. 3-2: } I_p = U_p \cdot M_{50} \cdot N$$

and secondary current as

$$\text{En. 3-3: } I_s = \frac{U_s - U_{off}}{R_s}$$

where

$U_p$  voltage measured at the output of the zero flux system,

$M_{50}$  current sensitivity of 50 A measuring head,

$N$  number of windings of the measured current,

$U_s$  voltage measured at the output of reference resistor,

$U_{off}$  voltage measured at the output of reference resistor when no current is applied,

$R_s$  resistance of the reference resistor.

### Calculation of ratio

The ratio R was calculated as

$$\text{En. 3-6: } R = \frac{I_s}{I_p}$$

### 9.3 Traceability

Traceability is ensured over the accredited calibration of reference digital multimeter (DC voltage) and reference resistor (DC resistance) according to SIQ's internal procedures. DC voltage is traceable to VSL and DC resistance is traceable to PTB. Zero Flux system is traceable to DC voltage and DC resistance over the Ohm's law.

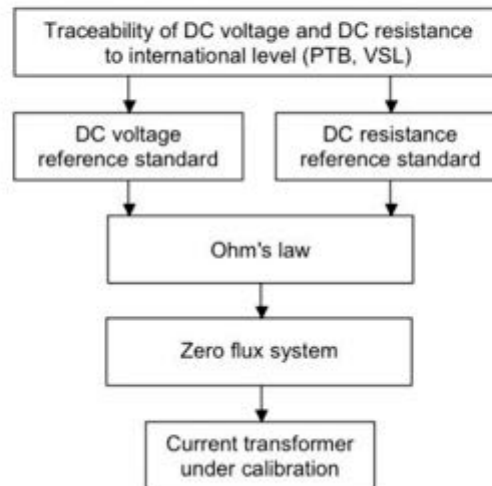

### 9.4 Ambient conditions

During the intercomparison the ambient conditions in the laboratory were within the limits:

- temperature:  $23^{\circ}\text{C} \pm 2^{\circ}\text{C}$ ,
- relative humidity:  $50\% \pm 20\%$ .

## 10. SP – SP Technical Research Institute of Sweden (Sweden)

### 10.1 Traceability scheme

The traceability scheme for the current ratio at SP at 90A and 300 A primary current is shown below.

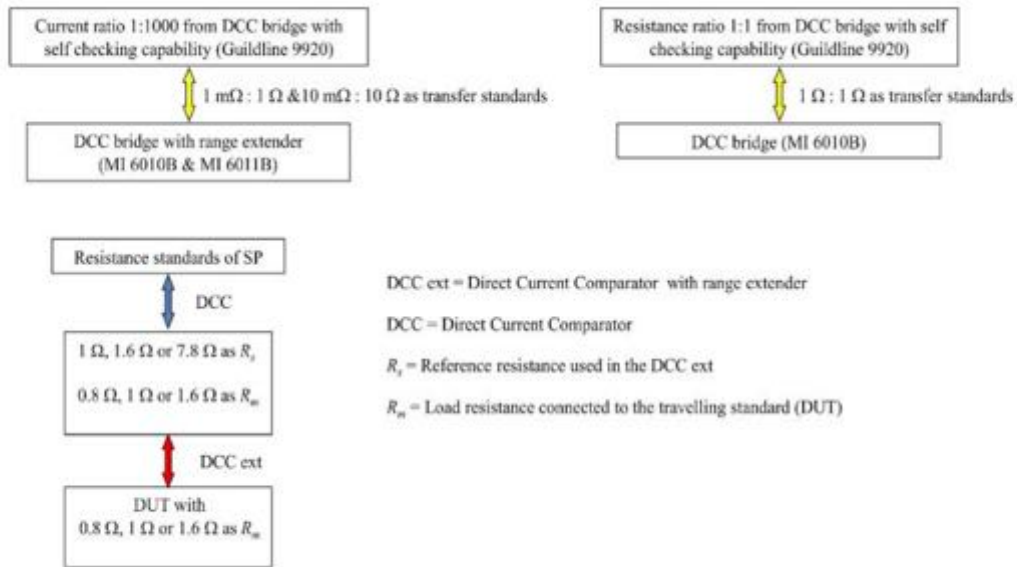

The self checking capability of our DCC bridge (Guidline 9920) was used to verify the 1:1 and 1:1000 current ratios of our DCC bridge (MI 6010B) and our DCC bridge with range extender (MI 6010B & MI 6011B) respectively. Some stable resistance standards were used as transfer standards. The resistance values of  $R_s$  and  $R_m$  respectively are traceable to our maintained resistance scaling at SP (verified with our Cryogenic Current Comparator). We get the current ratio of the DUT from the resistance values of  $R_s$  and  $R_m$  in combination with the verified current ratios of our DCC bridge with range extender.

### 10.2 Measurement set-up

The measurements on the travelling standard at 90 A and 300 A primary current were performed with a direct current comparator bridge (MI 6010B) with a range extender (MI 6011B) and a current source (MI 6100A or HP 6672A) controlled from a computer via a GPIB interface.

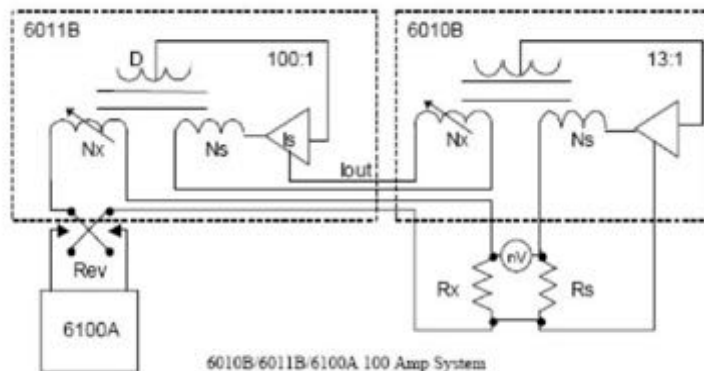

Fig. 1 Schematic picture of the measurement system where  $R_x$  in the figure is the DUT with connected load resistance  $R_m$  and  $R_s$  is the reference resistance used.

### 10.3 Measurement procedure

Close to the period of measurement the resistors used were calibrated against our maintained resistance level at SP. The resistance values of our resistance standards were determined from the known drift rate and also verified just after the period of measurement.

The travelling standard was connected as a virtual resistance ( $R_x$ ) to the measurement system in fig. 1 above. The current leads from the range extender (MI 6011B) were connected through the primary through hole of the DUT. The current leads from the load resistance ( $R_m$ ) were connected to the connection box (labelled Rm H and Rm L). The potential leads from  $R_m$  were connected as potential leads of the virtual resistance ( $R_x$ ).

Reference resistance standards ( $R_s$ ) of 1  $\Omega$ , 1.6  $\Omega$  or 7.8  $\Omega$  were used to calibrate the DUT at 90 A primary current with connected load resistance ( $R_m$ ) of 0.8  $\Omega$ , 1  $\Omega$  or 1.6  $\Omega$  and in combination with different number of turns of the primary current conductor through the primary through hole (1, 2, 3 or 20 turns). A reference resistance standard ( $R_s$ ) of 1.6  $\Omega$  was used to calibrate the DUT at 300 A primary current with connected load resistance ( $R_m$ ) of 0.8  $\Omega$  or 1  $\Omega$  and in combination with 3 turns of the primary current conductor through the primary through hole. The measurement values were taken as a mean value, after a few minutes of waiting for stability, of a number of readings in the resistance measurement system.

A number of test measurements were also done to get some idea of the sensitivity of the DUT for centering error and placement of the primary current conductor etc...

The measurements (90 A and 300 A primary current) were performed in a temperature- and humidity controlled laboratory with temperature ( $23 \pm 1$ ) °C and relative humidity ( $45 \pm 10$ ) %. Before starting any measurements the travelling standard was powered for more than 24 hours in the laboratory. During the whole measurement period the temperature and humidity in the laboratory was registered every five minutes with a logging system. The temperature on the primary current lead(s) close to the measuring head was also registered twice a minute with a Pt100 resistance thermometer with another logging system. The humidity and temperature around the measuring head was also logged by a third logging system every ten minutes. Also the power supply ( $\pm 15$  V) was logged with a digital multimeter during the measurements.

## 11. VSL – VSL Dutch Metrology Institute (Netherlands)

### 11.1 Environment

The CT was measured in a temperature controlled room stabilised at 23 °C. The typical temperature stability of the room is approximately 0.1 °C, but with better 1-hour stability.

The temperature of the room environment, the primary current conductor, the CT measurement head, the oil bath containing the measurement resistor, and the measurement rack containing the reference resistor was measured with a temperature measurement system based on an Agilent 34420A multimeter and a scanner using thermistors as the temperature sensing elements. The temperature sensors were placed such as to make good contact with the device from which the temperature is to be measured: they were located inside the temperature hole of the measurement and reference resistors, and mounted on the CT measurement head by means of self-adhesive copper tape. For the measurement of the temperature of the primary current conductors, the temperature sensor was placed between layers of copper foil around the conductors in order to homogenise the temperature (see picture below, where the copper foil has been subtracted out of the DUT centre hole).

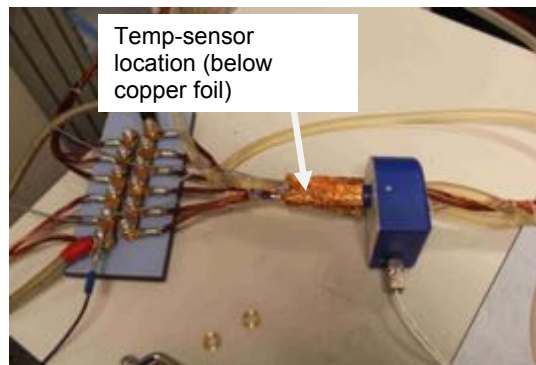

The temperature system was calibrated as a whole (multimeter with scanner and thermistors) to the level of 5 mK ( $k = 2$ ). There is an extra uncertainty in the temperature measurements due to a possible difference in the temperature measured by the sensor and the actual temperature of the DUT or resistor. This effect is estimated for the resistors to be at most 20 mK, and for the other temperatures at most 0.5 K. Adding all type A and type B uncertainty sources brings the total expanded uncertainty ( $k = 2$ ) of the temperature measurements of the resistors to around 45 mK. The uncertainty of the primary current bus temperature is dominated by the variation in temperature between different runs of measurements on various days.

The relative air humidity in the room is controlled around 45 % and measured by a Vaisala Humidity and Temperature Transmitter, type 233. This transmitter is calibrated with an uncertainty of 0.6 % ( $k = 2$ ). With extra contributions due to possible inhomogeneity of the humidity in the measurement room, and the actual variation of the humidity during the measurements, the total uncertainty in the relative air humidity measurements is estimated to be 2.5 % ( $k = 1$ ).

The air pressure was measured by a dual channel Druck DPI 101 pressure meter, with an overall uncertainty of 10 hPa ( $k = 2$ ).

The primary current conductors were cooled by means of a cooling unit and silicone tubing containing the cooling water, which was wrapped around the primary conductors to prevent that the temperature of the measuring head was warming up due to the dissipation in the current carrying conductors (see picture below). To improve the homogeneity in temperature seen by the DUT measuring head, copper foil with good thermal conductivity was wrapped around the conductors and silicone tubing (in picture below, the copper foil is seen in the back, withdrawn from the centre DUT hole). Depending on the primary current, the cooling water temperature was set such that the temperature in the measuring head was around 23 °C.



Figure 1. Measurement rack with the low-ohmic resistance bridge which consists of (from top to bottom): a HP6672A DC current source, a HP34401 current meter, a HP34420A null detector, a MI-6011A range extender, and a MI-4220A low thermal matrix scanner. Below the matrix scanner two reference resistance standards can be seen.

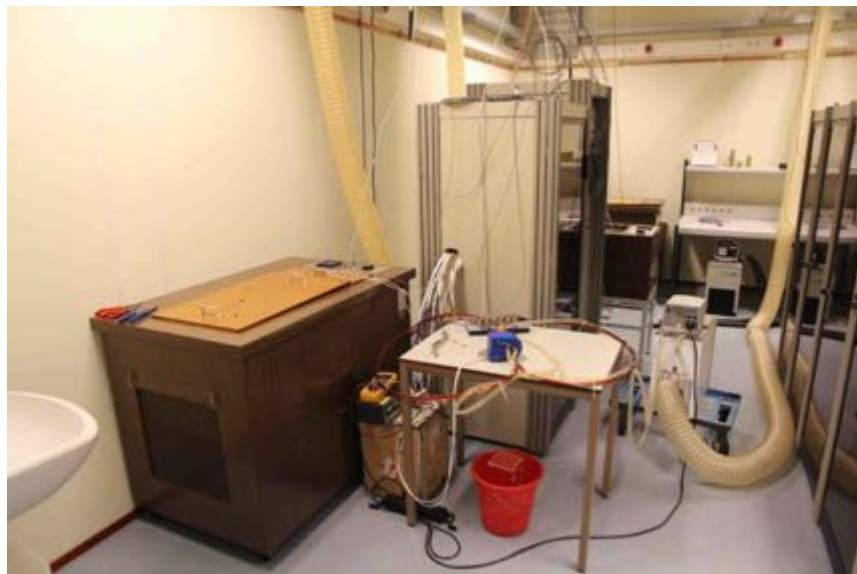

Figure 2. Overview of the VSL measurement setup during the comparison. Measurement rack with low-ohmic resistance bridge (back), water cooling unit (right), oil bath containing  $R_0$  resistors (left) and in the front the unit to be measured, the LEM IT-600 S current transformer, with several primary current loops (on the table in the middle). Note the two tubings which removed the heat from the oil bath and water cooling unit respectively, in order to minimise the heat load of the measurement room.

## 11.2 Measurement method

The starting point of the traceability of the high-DC current and high-DC current ratio measurements at VSL is a  $1\ \Omega$  reference resistor which is traceable to the Quantum Hall Effect (See 3.4 *Traceability Chart*). Subsequently, an adapted version of the VSL low-ohmic resistance bridge uses this reference resistor and an auxiliary resistor with value between  $0.25\ \Omega$  and  $1.5\ \Omega$  to calibrate the unknown DC current ratio of the device under test. In the following paragraphs we first shortly describe our low-ohmic resistance bridge, then the adapted bridge used for the DC current ratio measurements, and end with measurement method and traceability.

### LOW-OHMIC RESISTANCE MEASUREMENT BRIDGE

The basis of the DC current ratio measurement bridge is a low-ohmic resistance bridge, as depicted in figure 3 [1]. It is a dedicated home-built system, based on a commercial current comparator. A high-current source drives a large current  $I_x$  through  $R_x$ , and the internal current source  $I_s$  in the current comparator is adjusted by an internal feedback system such that the current ratio in the two arms of the bridge is equal to the reciprocal of the winding ratio of the comparator:  $N_s \cdot I_s = N_x \cdot I_x$ . The comparator has three winding ratios, 1:10, 1:100, and 1:1000, respectively. The applied current is measured with a current meter in the low-current arm of the bridge. A nanovoltmeter measures the voltage resulting from any deviation of the resistance ratio from the current ratio (i.e. the comparator winding ratio). Since the nanovoltmeter is not zeroed by a voltage feedback system its gain needs to be stable and known, which is not a problem with the high-quality nanovoltmeters that are presently commercially available, such as the Agilent 34420A used in our setup.

Computer control of the bridge is arranged via optical fibres to prevent any interference and ground loops.

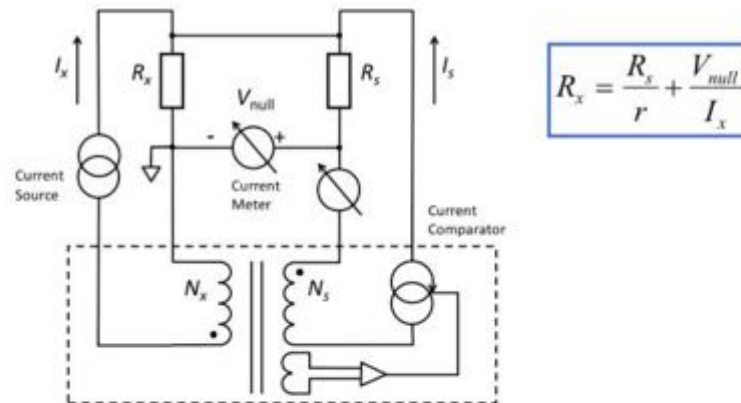

Figure 3. Schematic overview of the low-ohmic measurement bridge at VSL. The dashed box indicates the current comparator for balancing the currents in the two arms of the bridge. The DC high-current source can generate  $I_x$  currents up to 100 A.

A typical measurement on a single resistor contains 13 current reversals and the results of the last 10 reversals are used to calculate a resistance value. Dominant uncertainty sources in the setup are the noise in the measurements, the calibration of the nanovoltmeter, and the accuracy of the current comparator ratios. The latter is checked via an extensive series of cross-checks, for example for the 1:1000 ratio used in this DC current ratio comparison:

$$100\ \text{m}\Omega \rightarrow 10\ \text{m}\Omega \rightarrow 100\ \mu\Omega \rightarrow 100\ \text{m}\Omega.$$

In this check, the combined result of a 10:1 and 100:1 resistance measurement step is compared to a single 1000:1 step. This verification is considered a quite thorough check of the ratio accuracy of the current comparator. The agreement of this cross-check is excellent, with the three measurements agreeing within  $(-0.04 \pm 0.12)\ \mu\Omega/\Omega$  respectively ( $k = 1$  uncertainties).

The accuracy of the low-ohmic resistance bridge has been confirmed via a trilateral comparison with NIST and METAS [2].

### DC CURRENT RATIO MEASUREMENT BRIDGE

Figure 4 shows the adapted version of the low-ohmic resistance bridge as used for the calibration of the DC current ratio of the travelling standard in this comparison.

As explained in the previous section, in the regular resistance bridge the high current passes through the unknown resistor and compares the resulting voltage with the voltage across a reference resistor  $R_s$  in the other arm of the bridge. In the adapted DC current calibration bridge, the high current passes through the unknown DC current ratio device where its low current output is converted to a voltage using an auxiliary resistor  $R_d$ . This voltage is again compared to that across the reference resistor  $R_s$ . A significant difference with respect to the resistance bridge is that both resistors  $R_d$  and  $R_s$  carry small currents and thus suffer less from dissipation effects.

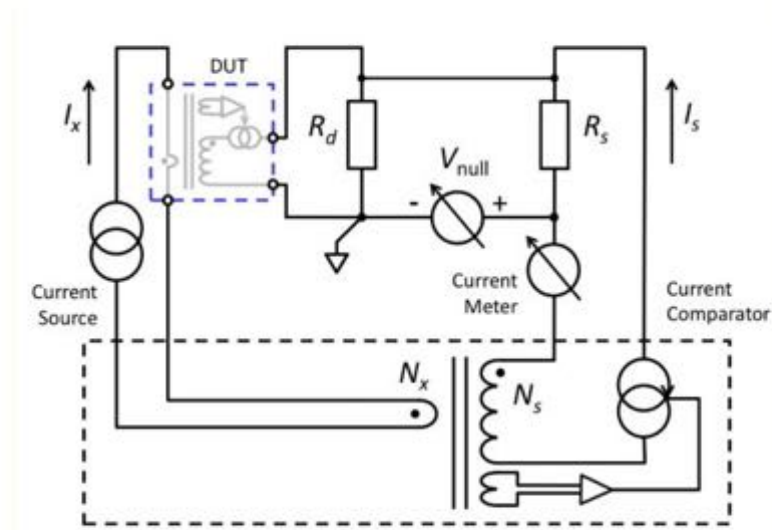

Figure 4. Schematic overview of the adapted low-ohmic measurement bridge at VSL used for DC current ratio measurements. The blue-dashed box at the left top indicates the device under test.

Note that the bridge is effectively comparing the unknown current ratio  $r_d$  of the device under test (DUT) with the calibrated ratio  $r_{cc}$  of the current comparator in the measurement bridge. The voltage  $V_d$  across  $R_d$  is

$$V_d = R_d \cdot I_d = R_d \cdot r_d \cdot I_x \quad (1)$$

Since the current comparator ensures ampere-turn balance

$$I_s \cdot N_s = I_x \cdot N_x, \quad (2)$$

which by the definition of  $r_{cc}$  equals to  $I_s = r_{cc} \cdot I_x$ , the voltage  $V_s$  across  $R_s$  is

$$V_s = R_s \cdot I_s = R_s \cdot I_x \cdot r_{cc}. \quad (3)$$

Taking into account a non-zero reading of the null-detector  $V_{null}$ , the unknown DC current ratio  $r_d$  of the device under test can finally be expressed as

$$r_d = r_{cc} \cdot (R_s / R_d) + V_{null} / (R_d \cdot I_x) \quad (4)$$

For unknown ratios  $r_d$  nominally equal to  $r_{cc}$ , the values of  $R_s$  and  $R_d$  should be taken equal. The  $V_{null}$  indication then is a direct measure for the deviation of  $r_d$  from  $r_{cc}$ . In the case of the present comparison where  $r_d$  differs from  $r_{cc}$ ,  $R_s$  values of 1.5  $\Omega$ , 0.5  $\Omega$ , and 0.25  $\Omega$  were used (see also next paragraphs).

The DC current source can generate only  $I_x$  currents up to 100 A. In order to calibrate the transfer standard at 300 A and 600 A, multiple turns (3 and 6 respectively) of the primary  $I_x$  current lead are made through the DUT. With  $N_d$  primary turns through the DUT, the effective current seen by the device is  $N_d \cdot I_x$ . In the comparison measurements, the correctness of this step-up approach was verified.

The selection of the resistor values of  $R_s$  and  $R_d$  depends on the current ratios to be calibrated. In this comparison the current comparator ratio  $r_{cc}$  is set to 1:1000. With the reference resistor  $R_s$  taken as 1  $\Omega$ , the dissipation in  $R_s$  is not exceeding 10 mW up to the maximum primary current  $I_x$  of 100 A. Since the device under test has a nominal ratio of

1:1500,  $R_d$  is taken as  $1.5 \Omega$  which is below the maximum allowed burden resistance of  $2.5 \Omega$  specified in the comparison protocol [4]. For the calibration at 300 A and 600 A, where 3 and 6 primary turns are used, the value of  $R_d$  is reduced accordingly to  $0.5 \Omega$  and  $0.25 \Omega$ .

Of particular importance is the positioning of the primary conductor in the DUT. Due to possible limitations in the shielding construction within the travelling standard, it may be sensitive for off-centric primary conductor positions. Therefore, special attention was paid to the centering of the current conductors and the actual effect of non-perfect centering was determined.

#### MEASUREMENT PROCEDURE

In a calibration, first the DC current is applied and the water cooling is adjusted such that the primary conductor temperature remains around  $23 \text{ }^\circ\text{C}$ . Then the correct value of  $R_d$  is arranged. In an oil bath (see figure 2) four L&N 4020B  $1\text{-}\Omega$  resistors were placed and using copper strips a series-parallel connection of the resistors was made in order to realize the correct nominal values of  $R_d$  (see figure 5). Since for each nominal current value in the comparison measurements a different value of  $R_d$  is needed,  $R_d$  values changed continuously. Thus the next step in the measurement process was to calibrate  $R_d$  and  $R_s$  against a  $1 \Omega$  reference standard using a separate current comparator bridge. Finally, before each measurement, the travelling standard was switched off and on, in order realize a well-defined starting point of the DUT electronics (previous measurements may have affected the DUT magnetic core).

After these preparations, the actual measurement of  $r_d$  was started using a similar procedure as followed in low-ohmic resistance measurements [1], [2], with the slight modification of the measurement software in order to determine the positive and negative current DC current ratios as described below.

After completion of the measurements at a certain current level,  $R_d$  and  $R_s$  were again calibrated against the  $1 \Omega$  reference standard using the separate current comparator bridge. This was especially important for  $R_d$  since the actual value of this resistor contains the varying contact resistances of the copper strips used to realize the correct nominal value of  $R_d$ . The change in measurement values of  $R_d$  before and after the measurement was taken into account as an uncertainty source.  $R_s$  essentially never changed in the course of a measurement; any measured changes larger than  $0.1 \text{ ppm}$  in  $R_s$  were caused by variations in temperature. These were corrected for using the known temperature coefficient of  $R_s$ .



*Figure 5. Photograph of the four L&N 4020B resistors used for realizing the different values of  $R_d$ . In the present configuration  $R_d$  is nominally  $1.5 \Omega$ ; two left resistors in parallel, and placed in series with the third resistor. Note the temperature sensor in the centre hole of the second resistor from the left. The bottom copper strip connecting the four resistors was not changed between the different configurations.*

Since the comparison protocol asks for the measurement of the DC current ratio of the travelling standard for positive current, negative current, and positive-negative current, at each current value three different measurements were performed. The DC current ratio of the travelling standard at positive current was determined by alternately applying positive current and zero current. The measurement at zero current is needed to correct for current and voltage offsets in the measurement bridge. Similarly, the measurement at negative current alternately applied negative and zero current. Finally, the DUT ratio of positive-negative current was determined by applying the measurement current with continuously reversed polarities. Note that this latter method does not automatically result in a measurement value that is the average value of the measurements for positive and negative current since the

dissipation in these cases is different (in the zero current part of the measurement there is no dissipation).

Verification of the step-up method using multiple turns is done by comparing the DUT readings with 1 turn at 90 A with that with 3 turns at 30 A, and by comparing the DUT readings with 3 turns at 100 A with that with 6 turns at 50 A.

To determine the uncertainty related to non-ideal centering of the current conductors in the traveling standard, the conductors were intentionally placed off-axis: top, bottom, left, and right in the centre hole of the DUT respectively, and for each of these positions the effective DC current ratio of the DUT was measured.

#### TRACEABILITY CHART

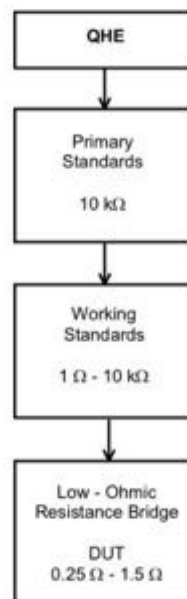

### 11.3 References

- [1] E. Houtzager and G. Rietveld, "Automated low-ohmic resistance measurements at the  $\mu\Omega/\Omega$  level", IEEE Transactions on Instrumentation and Measurement 56, pp. 406 - 409 (2007).
- [2] Gert Rietveld, Jan H. N. van der Beek, Marlin Kraft, Randolph Elmquist, Alessandro Mortara, and Beat Jeckelmann, "Low-Ohmic Resistance Comparison: Measurement Capabilities and Resistor Travelling Behavior", IEEE Transactions on Instrumentation and Measurement 62, pp. 1723 - 1728 (2013).
- [3] Gert Rietveld, Jan van der Beek, and Ernest Houtzager, "Accurate High-Current DC Current Ratio Measurements", Proceedings of the 2014 Conference on Precision Electromagnetic Measurements (CPEM 2014), Rio de Janeiro, Brasil, (2014).
- [4] C. Cassiogo and A. Mortara, "Supplementary Comparison EURAMET.EM-S35, Comparison of High-Current Ratio Standard - TECHNICAL PROTOCOL", 2012.

**Supplementary Comparison EURAMET.EM-35  
Comparison of High-Current Ratio Standard**

**FINAL REPORT – ANNEX C  
Uncertainty budgets**

C. Cassiago<sup>a</sup> and A. Mortara<sup>b</sup>

a Istituto Nazionale di Ricerca Metrologica, INRIM  
Strada delle Cacce 91, 10135 Turin, Italy

b Federal Institute of Metrology, METAS  
Lindenweg 50, 3003 Bern-Wabern, Switzerland

## Table of Contents

1. Introduction .....	3
2. CMI – Czech Metrology Institute (Czech Republic) .....	3
2.1 Uncertainty budget .....	3
3. INRIM – Istituto Nazionale di Ricerca Metrologica (Italy).....	6
3.1 Detailed uncertainty budget .....	6
4. LCOE – Laboratorio Central Oficial de Electrotecnia (Spain) .....	10
4.1 Detailed uncertainty budget .....	10
5. LNE – Laboratoire national de métrologie et d’essais (France) .....	13
5.1 Detailed uncertainty budget for measurements performed at 90 A .....	13
5.1 Detailed uncertainty budget for measurements performed at 300 A and 600 A.....	15
6. METAS – Federal Institute of Metrology METAS (Switzerland).....	20
6.1 Detailed uncertainty budget .....	20
6.2 Uncertainty of measurement .....	22
7. MIKES – Centre for Metrology and Accreditation (Finland).....	23
7.1 Measurement uncertainty .....	23
8. PTB – Physikalisch-Technische Bundesanstalt (Germany).....	28
8.1 Detailed uncertainty budget .....	28
9. SIQ – Slovenian Institute of Quality and Metrology (Slovenia).....	32
9.1 Uncertainty budgets .....	32
9.2 Measurement uncertainty calculation .....	34
10. SP – SP Technical Research Institute of Sweden (Sweden) .....	38
10.1 Detailed uncertainty budget .....	38
11. VSL – VSL Dutch Metrology Institute (Netherlands).....	40
11.1 Detailed uncertainty budget .....	40

## 1. Introduction

This is the list of uncertainty budgets estimated by each participant (sorted alphabetically by participant acronym), extracted from their comparison reports.

## 2. CMI – Czech Metrology Institute (Czech Republic)

### 2.1 Uncertainty budget

Uncertainty calculation of the  $R$  ratio corresponds to result of indirect measurement according to (3) and (4). The resulting standard type B relative uncertainty  $u(R)_B$  may be expressed as

$$u(R)_B = \sqrt{[u(I_p)]^2 + [u(I_s)]^2} = \sqrt{[u(U_{RN1})]^2 + [u(R_{N1})]^2 + [u(U_{RN2})]^2 + [u(R_{N2})]^2 + [u(T_{RN})]^2 + [u(PS)]^2} \quad (6)$$

where  $u(U_{RN1})$  is relative value of standard uncertainty of voltage reading  $U_{RN1}$  across the resistor  $R_{N1}$  (ppm),

$u(U_{RN2})$  is relative value of standard uncertainty of voltage reading  $U_{RN2}$  across the resistor  $R_{N2}$  (ppm),

$u(R_{N1})$  is relative value of standard uncertainty of resistor  $R_{N1}$  magnitude (ppm),

$u(R_{N2})$  is relative value of standard uncertainty of resistor  $R_{N2}$  magnitude (ppm),

$u(T_{RN})$  is relative value of standard uncertainty of resistor  $R_{N1}$  and  $R_{N2}$  change due to temperature variation (ppm),

$u(PS)$  is relative value of standard uncertainty due to supply voltage variation (ppm).

$R_{N1} = 9,99999 \cdot 10^{-3} \Omega \pm 11$  ppm (standard uncertainty 5,5 ppm) for  $I_p = 90$  A

$R_{N1} = 9,999418 \cdot 10^{-4} \Omega \pm 11$  ppm (standard uncertainty 5,5 ppm) for  $I_p = 300$  A and 600 A

$R_{N2} = 0,9999827 \Omega \pm 10$  ppm (standard uncertainty 5 ppm)

The voltages  $U_{RN1}$  and  $U_{RN2}$  were measured using two Agilent 3458A multimeters simultaneously triggered.

The type A uncertainty was calculated from 10 voltage measurements and results of  $R$  according to

$$u(R)_A = \sqrt{\frac{\sum_{i=1}^{20} (R_i - R_m)^2}{10 \cdot 9}}, \quad R_m = \frac{1}{10} \sum_{i=1}^{20} R_i. \quad (7)$$

The combined uncertainty  $u(R)_C$  is given as

$$u(R)_C = \sqrt{u(R)_A^2 + u(R)_B^2}. \quad (8)$$

**Table I. Uncertainty budget for primary current proud  $I_p = 90$  A**

Quantity/influence factor $X_i$	Estimate $x_i$	Standard uncer. $u(x_i)$ (ppm)	Probability distribution	Type	Sensitivity coefficient $c_i$	Uncertainty contribution $u_i$
Voltage $U_{RN1}$	0,899 V	4,8	Rectangular	B	1	4,8 ppm
Voltage $U_{RN2}$	59,9 mV	8,1	Rectangular	B	1	8,1 ppm
Standard resistor $R_{N1}$	$9,99999 \cdot 10^{-3} \Omega$	5,5	Rectangular	B	1	5,5 ppm
Standard resistor $R_{N2}$	0,9999827 $\Omega$	5	Rectangular	B	1	5 ppm
Temperature influence	-	5	Normal	B	1	5 ppm
Power votage influence	-	1	Normal	B	1	1 ppm
Resulting $u_B(R)$ (relative)	-			B		13 ppm
Resulting $u_B(R)$ (absolute)	-			B		8,7 E-9
Type A uncertainty $u_A(R)$ (30 measurements)	-		Normal	A		6,6 E-10
Combined uncertainty $u_C$	-			C		8,7 E-9
Expanded uncertainty $U(R)$ (k=2)	-			C		17,4 E-9

**Table II. Uncertainty budget for primary current  $I_p = 300$  A**

Quantity/influence factor $X_i$	Estimate $x_i$	Standard uncer. $u(x_i)$ (ppm)	Probability distribution	Type	Sensitivity coefficient $c_i$	Uncertainty contribution $u_i$
Voltage $U_{RN1}$	0,3028 V	5,2	Rectangular	B	1	5,2 ppm
Voltage $U_{RN2}$	0,2019 V	5,5	Rectangular	B	1	5,5 ppm
Standard resistor $R_{N1}$	$9,999418 \cdot 10^{-4} \Omega$	5,5	Rectangular	B	1	5,5 ppm
Standard resistor $R_{N2}$	0,9999827 $\Omega$	5	Rectangular	B	1	5 ppm
Temperature influence	-	5	Normal	B	1	8 ppm
Power votage influence	-	1	Normal	B	1	1 ppm
Resulting $u_B(R)$ (relative)	-			B		13,3 ppm
Resulting $u_B(R)$ (absolute)	-			B		8,8 E-9
Type A uncertainty $u_A(R)$ (30 measurements)	-		Normal	B		9,4 E-10
Combined uncertainty $u_C$	-		Rectangular	B		8,8 E-9
Expanded uncertainty $U(R)$ (k=2)	-					18 E-9

**Table III. Uncertainty budget for primary current  $I_P = 600$  A**

Quantity/influence factor $X_i$	Estimate $x_i$	Standard uncer. $u(x_i)$ (ppm)	Probability distribution	Type	Sensitivity coefficient $c_i$	Uncertainty contribution $u_i$
Voltage $U_{RN1}$	0,5996 V	4,8	Rectangular	B	1	4,9 ppm
Voltage $U_{RN2}$	0,3999 V	8,1	Rectangular	B	1	5,05 ppm
Standard resistor $R_{N1}$	$9,999418 \cdot 10^{-4} \Omega$	5,5	Rectangular	B	1	5,5 ppm
Standard resistor $R_{N2}$	0,9999827 $\Omega$	5	Rectangular	B	1	5 ppm
Temperature influence	-	5	Normal	B	1	10 ppm
Power votage influence	-	1	Normal	B	1	1 ppm
Resulting $u_B(R)$ (relative)	-			B		14,3 ppm
Resulting $u_B(R)$ (absolute)	-			B		9,5 E-9
Type A uncertainty $u_A(R)$ (30 measurements)	-		Normal	B		2,2 E- 9
Combined uncertainty $u_C$	-		Rectangular	B		9,8 E-9
Expanded uncertainty $U(R)$ (k=2)	-					20 E-9

### 3. INRIM – Istituto Nazionale di Ricerca Metrologica (Italy)

#### 3.1 Detailed uncertainty budget

The  $R_+$  and  $R_-$  uncertainties were evaluated from the models given in (3) and (4), considering the input quantities uncorrelated. Then, the expression of uncertainty is

$$u(R) = \sqrt{\left(\frac{n_{CD}}{I_P}\right)^2 u^2(\Delta I_C) + \left(n_{CD} \frac{\Delta I_C}{I_P^2}\right)^2 u^2(I_P) + \left(\frac{\Delta I_C}{I_P}\right)^2 u^2(n_{CD}) + G_E^2 u^2(n_{ED}) + n_{ED}^2 u^2(G_E)} \quad (8)$$

and the detailed budgets for the different currents  $I_P$  are given in the following tables “a” and “b”. The  $R_M$  uncertainty was evaluated from the model given in (7), considering the contributions coming by  $\Delta I_C$  as uncorrelated, and those ones coming from  $I_P$ ,  $n_{CD}$ ,  $n_{ED}$ , and  $G_E$  as totally correlated. Then, the expression of uncertainty is

$$u(R_M) = \frac{1}{2} \left\{ u^2(\Delta I_C)_{R_+} + u^2(\Delta I_C)_{R_-} + [u(I_P)_{R_+} + u(I_P)_{R_-}]^2 + [u(n_{CD})_{R_+} + u(n_{CD})_{R_-}]^2 + [u(n_{ED})_{R_+} + u(n_{ED})_{R_-}]^2 + [(G_E)_{R_+} + (G_E)_{R_-}]^2 \right\}^{1/2} \quad (9)$$

and the values for the different currents  $I_P$  are given in the following tables “c”.

Quantity $X_i$	Estimate $x_i$	Std. unc. $u(x_i)$	Type	Sens. coeff. $c_i$	Unc. contrib. $u(y_i)$	DOF $v_i$	Note
$\Delta I_C$	22.7 $\mu$ A	0.45 $\mu$ A	A	$-7.4 \times 10^{-5}$	$3.3 \times 10^{-11}$	14	Standard deviation of the mean
$I_P$	+90 A	90 mA	B	$-1.9 \times 10^{-11}$	$1.7 \times 10^{-12}$	$\infty$	$A_D$ readings (bound on maximum error)
$n_{CD}$	$-6.6666667 \times 10^{-3}$	$6.7 \times 10^{-10}$	B	$2.5 \times 10^{-7}$	$1.7 \times 10^{-16}$	$\infty$	CC instrument specifications
$n_{ED}$	$-6.6666667 \times 10^{-1}$	$6.7 \times 10^{-8}$	B	$1.0 \times 10^{-3}$	$6.7 \times 10^{-11}$	$\infty$	CC instrument specifications
$G_E$	$1.0000000 \times 10^{-3}$	$5.8 \times 10^{-11}$	B	$-6.7 \times 10^{-1}$	$3.8 \times 10^{-11}$	$\infty$	EXT CC instrument specifications
$R_+$	$6.6666835 \times 10^{-4}$	$8.4 \times 10^{-11}$					
$U(R_+)$		$1.7 \times 10^{-10}$					Expanded uncertainty, 95% coverage probability
$\delta R_+$	$2.53 \times 10^{-6}$	$1.3 \times 10^{-7}$					
$U(\delta R_+)$		$2.5 \times 10^{-7}$					Expanded uncertainty, 95% coverage probability

Tab. 3a – Uncertainty budget for the ratio  $R_+$  (Loop1,  $I_P = +90$  A)

Quantity $X_i$	Estimate $x_i$	Std. unc. $u(x_i)$	Type	Sens. coeff. $c_i$	Unc. contrib. $u(y_i)$	DOF $v_i$	Note
$\Delta I_C$	-22.1 $\mu$ A	1.02 $\mu$ A	A	$7.4 \times 10^{-5}$	$7.5 \times 10^{-11}$	14	Standard deviation of the mean
$I_P$	-90 A	90 mA	B	$1.8 \times 10^{-11}$	$1.6 \times 10^{-12}$	$\infty$	$A_D$ readings (bound on maximum error)
$n_{CD}$	$-6.6666667 \times 10^{-3}$	$6.7 \times 10^{-10}$	B	$2.5 \times 10^{-7}$	$1.7 \times 10^{-16}$	$\infty$	CC instrument specifications
$n_{ED}$	$-6.6666667 \times 10^{-1}$	$6.7 \times 10^{-8}$	B	$1.0 \times 10^{-3}$	$6.7 \times 10^{-11}$	$\infty$	CC instrument specifications
$G_E$	$1.0000000 \times 10^{-3}$	$5.8 \times 10^{-11}$	B	$-6.7 \times 10^{-1}$	$3.8 \times 10^{-11}$	$\infty$	EXT CC instrument specifications
$R_+$	$6.6666831 \times 10^{-4}$	$1.1 \times 10^{-10}$					
$U(R_+)$		$2.2 \times 10^{-10}$					Expanded uncertainty, 95% coverage probability
$\delta R_+$	$2.46 \times 10^{-6}$	$1.6 \times 10^{-7}$					
$U(\delta R_+)$		$3.2 \times 10^{-7}$					Expanded uncertainty, 95% coverage probability

Tab. 3b – Uncertainty budget for the ratio  $R_-$  (Loop1,  $I_P = -90$  A)

Quantity $Y$	Estimate $y$	Std. unc. $u(y)$	Note
$R_M$	$6.6666833 \times 10^{-4}$	$8.7 \times 10^{-11}$	$I_P = 90$ A
$U(R_M)$		$1.8 \times 10^{-10}$	Expanded uncertainty, 95% coverage probability
$\delta R_M$	$2.49 \times 10^{-6}$	$1.3 \times 10^{-7}$	
$U(\delta R_M)$		$2.6 \times 10^{-7}$	Expanded uncertainty, 95% coverage probability

Tab. 3c – Uncertainty budget for average ratio  $R_M$  (Loop 1)

Quantity $X_i$	Estimate $x_i$	Std. unc. $u(x_i)$	Type	Sens. coeff. $c_i$	Unc. contrib. $u(y_i)$	DOF $\nu_i$	Note
$\Delta I_C$	-10.8 $\mu$ A	0.67 $\mu$ A	A	$-2.2 \times 10^{-5}$	$1.5 \times 10^{-11}$	3	Standard deviation of the mean
$I_P$	+300 A	300 mA	B	$8.0 \times 10^{-13}$	$2.4 \times 10^{-13}$	$\infty$	$A_D$ readings (bound on maximum error)
$n_{CD}$	$-6.6666667 \times 10^{-3}$	$6.7 \times 10^{-10}$	B	$-3.6 \times 10^{-8}$	$2.4 \times 10^{-17}$	$\infty$	CC instrument specifications
$n_{ED}$	$-6.6666667 \times 10^{-1}$	$6.7 \times 10^{-8}$	B	$1.0 \times 10^{-3}$	$6.7 \times 10^{-11}$	$\infty$	CC instrument specifications
$G_E$	$1.0000000 \times 10^{-3}$	$1.2 \times 10^{-9}$	B	$-6.7 \times 10^{-1}$	$7.7 \times 10^{-10}$	$\infty$	EXT CC instrument specifications
$R_+$	$6.6666643 \times 10^{-4}$	$7.7 \times 10^{-10}$					
$U(R_+)$		$1.5 \times 10^{-9}$					Expanded uncertainty, 95% coverage probability
$\delta R_+$	$-0.36 \times 10^{-6}$	$1.2 \times 10^{-6}$					
$U(\delta R_+)$		$2.3 \times 10^{-6}$					Expanded uncertainty, 95% coverage probability

Tab. 4a – Uncertainty budget for the ratio  $R_+$  (Loop 1,  $I_P = +300$  A)

Quantity $X_i$	Estimate $x_i$	Std. unc. $u(x_i)$	Type	Sens. coeff. $c_i$	Unc. contrib. $u(y_i)$	DOF $\nu_i$	Note
$\Delta I_C$	-23.0 $\mu$ A	0.75 $\mu$ A	A	$2.2 \times 10^{-5}$	$1.7 \times 10^{-11}$	3	Standard deviation of the mean
$I_P$	-300 A	300 mA	B	$1.7 \times 10^{-12}$	$5.1 \times 10^{-13}$	$\infty$	$A_D$ readings (bound on maximum error)
$n_{CD}$	$-6.6666667 \times 10^{-3}$	$6.7 \times 10^{-10}$	B	$7.7 \times 10^{-8}$	$5.1 \times 10^{-17}$	$\infty$	CC instrument specifications
$n_{ED}$	$-6.6666667 \times 10^{-1}$	$6.7 \times 10^{-8}$	B	$1.0 \times 10^{-3}$	$6.7 \times 10^{-11}$	$\infty$	CC instrument specifications
$G_E$	$1.0000000 \times 10^{-3}$	$1.2 \times 10^{-11}$	B	$-6.7 \times 10^{-1}$	$7.7 \times 10^{-10}$	$\infty$	EXT CC instrument specifications
$R_-$	$6.6666718 \times 10^{-4}$	$7.7 \times 10^{-10}$					
$U(R_-)$		$1.5 \times 10^{-9}$					Expanded uncertainty, 95% coverage probability
$\delta R_-$	$0.77 \times 10^{-6}$	$1.2 \times 10^{-6}$					
$U(\delta R_-)$		$2.3 \times 10^{-6}$					Expanded uncertainty, 95% coverage probability

Tab. 4b – Uncertainty budget for the ratio  $R_-$  (Loop 1,  $I_P = -300$  A)

Quantity $Y$	Estimate $y$	Std. unc. $u(y)$	Note
$R_M$	$6.6666680 \times 10^{-4}$	$7.7 \times 10^{-10}$	$I_P = 300$ A
$U(R_M)$		$1.6 \times 10^{-9}$	Expanded uncertainty, 95% coverage probability
$\delta R_M$	$0.20 \times 10^{-6}$	$1.6 \times 10^{-6}$	
$U(\delta R_M)$		$2.3 \times 10^{-6}$	Expanded uncertainty, 95% coverage probability

Tab. 4c – Uncertainty budget for average ratio  $R_M$  (Loop 1)

Quantity $X_i$	Estimate $x_i$	Std. unc. $u(x_i)$	Type	Sens. coeff. $c_i$	Unc. contrib. $u(y_i)$	DOF $\nu_i$	Note
$\Delta I_C$	-67.6 $\mu$ A	2.33 $\mu$ A	A	$-1.1 \times 10^{-5}$	$2.6 \times 10^{-11}$	3	Standard deviation of the mean
$I_P$	+600 A	600 mA	B	$1.3 \times 10^{-12}$	$7.5 \times 10^{-13}$	$\infty$	$A_D$ readings (bound on maximum error)
$n_{CD}$	$-6.6666667 \times 10^{-3}$	$6.7 \times 10^{-10}$	B	$-1.1 \times 10^{-7}$	$7.5 \times 10^{-17}$	$\infty$	CC instrument specifications
$n_{ED}$	$-6.6666667 \times 10^{-1}$	$6.7 \times 10^{-8}$	B	$1.0 \times 10^{-3}$	$6.7 \times 10^{-11}$	$\infty$	CC instrument specifications
$G_E$	$1.0000000 \times 10^{-3}$	$1.2 \times 10^{-9}$	B	$-6.7 \times 10^{-1}$	$7.7 \times 10^{-10}$	$\infty$	EXT CC instrument specifications
$R_+$	$6.6666592 \times 10^{-4}$	$7.7 \times 10^{-10}$					
$U(R_+)$		$1.5 \times 10^{-9}$					Expanded uncertainty, 95% coverage probability
$\delta R_+$	$-1.13 \times 10^{-6}$	$1.2 \times 10^{-6}$					
$U(\delta R_+)$		$2.3 \times 10^{-6}$					Expanded uncertainty, 95% coverage probability

Tab. 5a – Uncertainty budget for the ratio  $R_+$  (Loop 1,  $I_P = +600$  A)

Quantity $X_i$	Estimate $x_i$	Std. unc. $u(x_i)$	Type	Sens. coeff. $c_i$	Unc. contrib. $u(y_i)$	DOF $\nu_i$	Note
$\Delta I_C$	-63.2 $\mu$ A	1.18 $\mu$ A	A	$1.1 \times 10^{-5}$	$1.3 \times 10^{-11}$	3	Standard deviation of the mean
$I_P$	-600 A	600 mA	B	$1.2 \times 10^{-12}$	$7.0 \times 10^{-13}$	$\infty$	$A_D$ readings (bound on maximum error)
$n_{CD}$	$-6.6666667 \times 10^{-3}$	$6.7 \times 10^{-10}$	B	$1.1 \times 10^{-7}$	$7.0 \times 10^{-17}$	$\infty$	CC instrument specifications
$n_{ED}$	$-6.6666667 \times 10^{-1}$	$6.7 \times 10^{-8}$	B	$1.0 \times 10^{-3}$	$6.7 \times 10^{-11}$	$\infty$	CC instrument specifications
$G_E$	$1.0000000 \times 10^{-3}$	$1.2 \times 10^{-9}$	B	$-6.7 \times 10^{-1}$	$7.7 \times 10^{-10}$	$\infty$	EXT CC instrument specifications
$R_-$	$6.6666737 \times 10^{-4}$	$7.7 \times 10^{-10}$					
$U(R_-)$		$1.5 \times 10^{-9}$					Expanded uncertainty, 95% coverage probability
$\delta R_-$	$1.05 \times 10^{-6}$	$1.2 \times 10^{-6}$					
$U(\delta R_-)$		$2.3 \times 10^{-6}$					Expanded uncertainty, 95% coverage probability

Tab. 5b – Uncertainty budget for the ratio  $R_-$  (Loop 1,  $I_P = -600$  A)

Quantity $Y$	Estimate $y$	Std. unc. $u(y)$	Note
$R_M$	$6.6666664 \times 10^{-4}$	$7.7 \times 10^{-10}$	$I_P = 600$ A
$U(R_M)$		$1.6 \times 10^{-9}$	Expanded uncertainty, 95% coverage probability
$\delta R_M$	$-0.04 \times 10^{-6}$	$1.2 \times 10^{-6}$	
$U(\delta R_M)$		$2.3 \times 10^{-6}$	Expanded uncertainty, 95% coverage probability

Tab. 5c – Uncertainty budget for average ratio  $R_M$  (Loop 1)

Quantity $X_i$	Estimate $x_i$	Std. unc. $u(x_i)$	Type	Sens. coeff. $c_i$	Unc. contrib. $u(y_i)$	DOF $v_i$	Note
$\Delta I_C$	-7.0 $\mu$ A	0.27 $\mu$ A	A	$-7.4 \times 10^{-5}$	$2.0 \times 10^{-11}$	14	Standard deviation of the mean
$I_P$	+90 A	90 mA	B	$5.7 \times 10^{-12}$	$5.2 \times 10^{-13}$	$\infty$	$A_D$ readings (bound on maximum error)
$n_{CD}$	$-6.6666667 \times 10^{-3}$	$6.7 \times 10^{-10}$	B	$-7.7 \times 10^{-8}$	$5.2 \times 10^{-17}$	$\infty$	CC instrument specifications
$n_{ED}$	$-6.6666667 \times 10^{-1}$	$6.7 \times 10^{-8}$	B	$1.0 \times 10^{-3}$	$6.7 \times 10^{-11}$	$\infty$	CC instrument specifications
$G_E$	$1.0000000 \times 10^{-3}$	$5.8 \times 10^{-11}$	B	$-6.7 \times 10^{-1}$	$3.8 \times 10^{-11}$	$\infty$	EXT CC instrument specifications
$R^+$	$6.6666615 \times 10^{-4}$	$8.0 \times 10^{-11}$					
$U(R^+)$		$1.6 \times 10^{-10}$					Expanded uncertainty, 95% coverage probability
$\delta R^+$	$-0.77 \times 10^{-6}$	$1.2 \times 10^{-7}$					
$U(\delta R^+)$		$2.4 \times 10^{-7}$					Expanded uncertainty, 95% coverage probability

Tab. 6a – Uncertainty budget for the ratio  $R^+$  (Loop 2,  $I_P = +90$  A)

Quantity $X_i$	Estimate $x_i$	Std. unc. $u(x_i)$	Type	Sens. coeff. $c_i$	Unc. contrib. $u(y_i)$	DOF $v_i$	Note
$\Delta I_C$	3.7 $\mu$ A	0.13 $\mu$ A	A	$7.4 \times 10^{-5}$	$9.5 \times 10^{-12}$	14	Standard deviation of the mean
$I_P$	-90 A	90 mA	B	$-3.0 \times 10^{-12}$	$2.7 \times 10^{-13}$	$\infty$	$A_D$ readings (bound on maximum error)
$n_{CD}$	$-6.6666667 \times 10^{-3}$	$6.7 \times 10^{-10}$	B	$-4.1 \times 10^{-8}$	$2.7 \times 10^{-17}$	$\infty$	CC instrument specifications
$n_{ED}$	$-6.6666667 \times 10^{-1}$	$6.7 \times 10^{-8}$	B	$1.0 \times 10^{-3}$	$6.7 \times 10^{-11}$	$\infty$	CC instrument specifications
$G_E$	$1.0000000 \times 10^{-3}$	$5.8 \times 10^{-11}$	B	$-6.7 \times 10^{-1}$	$3.8 \times 10^{-11}$	$\infty$	EXT CC instrument specifications
$R^-$	$6.6666639 \times 10^{-4}$	$7.8 \times 10^{-11}$					
$U(R^-)$		$1.5 \times 10^{-10}$					Expanded uncertainty, 95% coverage probability
$\delta R^-$	$-0.41 \times 10^{-6}$	$1.2 \times 10^{-7}$					
$U(\delta R^-)$		$2.3 \times 10^{-7}$					Expanded uncertainty, 95% coverage probability

Tab. 6b – Uncertainty budget for the ratio  $R^-$  (Loop 2,  $I_P = -90$  A)

Quantity $Y$	Estimate $y$	Std. unc. $u(y)$	Note
$R_M$	$6.6666627 \times 10^{-4}$	$7.8 \times 10^{-11}$	$I_P = 90$ A
$U(R_M)$		$1.6 \times 10^{-10}$	Expanded uncertainty, 95% coverage probability
$\delta R_M$	$-0.59 \times 10^{-6}$	$1.2 \times 10^{-7}$	
$U(\delta R_M)$		$2.3 \times 10^{-7}$	Expanded uncertainty, 95% coverage probability

Tab. 6c – Uncertainty budget for average ratio  $R_M$  (Loop 2)

Quantity $X_i$	Estimate $x_i$	Std. unc. $u(x_i)$	Type	Sens. coeff. $c_i$	Unc. contrib. $u(y_i)$	DOF $v_i$	Note
$\Delta I_C$	-15.0 $\mu$ A	0.30 $\mu$ A	A	$-2.2 \times 10^{-5}$	$6.7 \times 10^{-12}$	7	Standard deviation of the mean
$I_P$	+300 A	300 mA	B	$1.1 \times 10^{-12}$	$3.3 \times 10^{-13}$	$\infty$	$A_D$ readings (bound on maximum error)
$n_{CD}$	$-6.6666667 \times 10^{-3}$	$6.7 \times 10^{-10}$	B	$-5.0 \times 10^{-8}$	$3.3 \times 10^{-17}$	$\infty$	CC instrument specifications
$n_{ED}$	$-6.6666667 \times 10^{-1}$	$6.7 \times 10^{-8}$	B	$1.0 \times 10^{-3}$	$6.7 \times 10^{-11}$	$\infty$	CC instrument specifications
$G_E$	$1.0000000 \times 10^{-3}$	$5.8 \times 10^{-11}$	B	$-6.7 \times 10^{-1}$	$7.7 \times 10^{-10}$	$\infty$	EXT CC instrument specifications
$R^+$	$6.6666633 \times 10^{-4}$	$7.7 \times 10^{-10}$					
$U(R^+)$		$1.5 \times 10^{-9}$					Expanded uncertainty, 95% coverage probability
$\delta R^+$	$-0.50 \times 10^{-6}$	$1.2 \times 10^{-6}$					
$U(\delta R^+)$		$2.3 \times 10^{-6}$					Expanded uncertainty, 95% coverage probability

Tab. 7a – Uncertainty budget for the ratio  $R^+$  (Loop 2,  $I_P = +300$  A)

Quantity $X_i$	Estimate $x_i$	Std. unc. $u(x_i)$	Type	Sens. coeff. $c_i$	Unc. contrib. $u(y_i)$	DOF $v_i$	Note
$\Delta I_C$	1.2 $\mu$ A	0.62 $\mu$ A	A	$2.2 \times 10^{-5}$	$1.4 \times 10^{-11}$	7	Standard deviation of the mean
$I_P$	-300 A	300 mA	B	$-8.8 \times 10^{-14}$	$2.6 \times 10^{-14}$	$\infty$	$A_D$ readings (bound on maximum error)
$n_{CD}$	$-6.6666667 \times 10^{-3}$	$6.7 \times 10^{-10}$	B	$-3.9 \times 10^{-9}$	$2.6 \times 10^{-18}$	$\infty$	CC instrument specifications
$n_{ED}$	$-6.6666667 \times 10^{-1}$	$6.7 \times 10^{-8}$	B	$1.0 \times 10^{-3}$	$6.7 \times 10^{-11}$	$\infty$	CC instrument specifications
$G_E$	$1.0000000 \times 10^{-3}$	$5.8 \times 10^{-11}$	B	$-6.7 \times 10^{-1}$	$7.7 \times 10^{-10}$	$\infty$	EXT CC instrument specifications
$R^-$	$6.6666664 \times 10^{-4}$	$7.7 \times 10^{-10}$					
$U(R^-)$		$1.5 \times 10^{-9}$					Expanded uncertainty, 95% coverage probability
$\delta R^-$	$-0.04 \times 10^{-6}$	$1.2 \times 10^{-6}$					
$U(\delta R^-)$		$2.3 \times 10^{-6}$					Expanded uncertainty, 95% coverage probability

Tab. 7b – Uncertainty budget for the ratio  $R^-$  (Loop 2,  $I_P = -300$  A)

Quantity $Y$	Estimate $y$	Std. unc. $u(y)$	Note
$R_M$	$6.6666649 \times 10^{-4}$	$7.7 \times 10^{-10}$	$I_P = 300$ A
$U(R_M)$		$1.5 \times 10^{-9}$	Expanded uncertainty, 95% coverage probability
$\delta R_M$	$-0.27 \times 10^{-6}$	$1.2 \times 10^{-6}$	
$U(\delta R_M)$		$2.3 \times 10^{-6}$	Expanded uncertainty, 95% coverage probability

Tab. 7c – Uncertainty budget for average ratio  $R_M$  (Loop 2)

Quantity $X_i$	Estimate $x_i$	Std. unc. $u(x_i)$	Type	Sens. coeff. $c_i$	Unc. contrib. $u(y_i)$	DOF $\nu_i$	Note
$\Delta I_C$	-17.6 $\mu$ A	2.13 $\mu$ A	A	$-1.1 \times 10^{-5}$	$2.4 \times 10^{-11}$	5	Standard deviation of the mean
$I_P$	+600 A	600 mA	B	$3.3 \times 10^{-13}$	$2.0 \times 10^{-13}$	$\infty$	$A_D$ readings (bound on maximum error)
$n_{CD}$	$-6.6666667 \times 10^{-3}$	$6.7 \times 10^{-10}$	B	$-2.9 \times 10^{-8}$	$2.0 \times 10^{-17}$	$\infty$	CC instrument specifications
$n_{ED}$	$-6.6666667 \times 10^{-1}$	$6.7 \times 10^{-8}$	B	$1.0 \times 10^{-3}$	$6.7 \times 10^{-11}$	$\infty$	CC instrument specifications
$G_E$	$1.0000000 \times 10^{-3}$	$5.8 \times 10^{-11}$	B	$-6.7 \times 10^{-1}$	$7.7 \times 10^{-10}$	$\infty$	EXT CC instrument specifications
$R_+$	$6.6666647 \times 10^{-4}$	$7.7 \times 10^{-10}$					
$U(R_+)$		$1.5 \times 10^{-9}$					Expanded uncertainty, 95% coverage probability
$\delta R_+$	$-0.29 \times 10^{-6}$	$1.2 \times 10^{-6}$					
$U(\delta R_+)$		$2.3 \times 10^{-6}$					Expanded uncertainty, 95% coverage probability

Tab. 8a – Uncertainty budget for the ratio  $R_+$  (Loop 2,  $I_P = +600$  A)

Quantity $X_i$	Estimate $x_i$	Std. unc. $u(x_i)$	Type	Sens. coeff. $c_i$	Unc. contrib. $u(y_i)$	DOF $\nu_i$	Note
$\Delta I_C$	2.8 $\mu$ A	0.71 $\mu$ A	A	$1.1 \times 10^{-5}$	$7.8 \times 10^{-12}$	5	Standard deviation of the mean
$I_P$	-600 A	600 mA	B	$-5.2 \times 10^{-14}$	$3.1 \times 10^{-14}$	$\infty$	$A_D$ readings (bound on maximum error)
$n_{CD}$	$-6.6666667 \times 10^{-3}$	$6.7 \times 10^{-10}$	B	$-4.7 \times 10^{-9}$	$3.1 \times 10^{-18}$	$\infty$	CC instrument specifications
$n_{ED}$	$-6.6666667 \times 10^{-1}$	$6.7 \times 10^{-8}$	B	$1.0 \times 10^{-3}$	$6.7 \times 10^{-11}$	$\infty$	CC instrument specifications
$G_E$	$1.0000000 \times 10^{-3}$	$5.8 \times 10^{-11}$	B	$-6.7 \times 10^{-1}$	$7.7 \times 10^{-10}$	$\infty$	EXT CC instrument specifications
$R_-$	$6.6666664 \times 10^{-4}$	$7.7 \times 10^{-10}$					
$U(R_-)$		$1.5 \times 10^{-9}$					Expanded uncertainty, 95% coverage probability
$\delta R_-$	$-0.05 \times 10^{-6}$	$1.2 \times 10^{-6}$					
$U(\delta R_-)$		$2.3 \times 10^{-6}$					Expanded uncertainty, 95% coverage probability

Tab. 8b – Uncertainty budget for the ratio  $R_-$  (Loop 2,  $I_P = -600$  A)

Quantity $Y$	Estimate $y$	Std. unc. $u(y)$	Note
$R_M$	$6.6666655 \times 10^{-4}$	$7.7 \times 10^{-10}$	$I_P = 600$ A
$U(R_M)$		$1.5 \times 10^{-9}$	Expanded uncertainty, 95% coverage probability
$\delta R_M$	$-0.17 \times 10^{-6}$	$1.2 \times 10^{-6}$	
$U(\delta R_M)$		$2.3 \times 10^{-6}$	Expanded uncertainty, 95% coverage probability

Tab. 8c – Uncertainty budget for average ratio  $R_M$  (Loop 2)

## 4. LCOE – Laboratorio Central Oficial de Electrotecnia (Spain)

### 4.1 Detailed uncertainty budget

The model function is different depending of the calibration current, so that two slightly different model functions are proposed, one for low currents and a different one for 600 A. Model function to determine R+, or R- is the same.

a) For 90 A and 300 A.

$$R = \frac{R_p}{R_s} \cdot \sum_{j=1}^{j=10} \left( \frac{V_{s,j(+)} + V_{s,j(-)} - 2V_{off,j}}{V_{p,j(+)} + V_{p,j(-)}} \right) \cdot (1 + \delta_{Vratio} + \delta_{centered})$$

$$R = \frac{R_p}{R_s} \cdot V_{ratio} \cdot (1 + \delta_{Vratio} + \delta_{centered})$$

b) For 600 A.

$$R = \frac{\overline{R_p}}{R_s} \cdot \sum_{j=1}^{j=10} \left( \frac{V_{s,j(+)} + V_{s,j(-)} - 2V_{off,j}}{V_{pa,j(+)} + V_{pa,j(-)} + V_{pb,j(+)} + V_{pb,j(-)}} \right) \cdot (1 + \delta_{Vratio} + \delta_{centered})$$

$$R = \frac{\overline{R_p}}{R_s} \cdot V_{ratio} \cdot (1 + \delta_{Vratio} + \delta_{centered})$$

$$\overline{R_p} = \frac{R_{p,a} + R_{p,b}}{2}$$

where:

$R_p$ ,	high current LCOE standard resistor certificate value for 90 A or 300 A
$R_{pa}$ , $R_{pb}$ ,	certificate value of the two standard LCOE resistors connected in parallel for 600 A.
$R_s$ ,	1 Ohm LCOE standard resistor certificate value.
$V_{s,j(+)}$	Voltage drop in $R_s$ when a positive current is passed through $R_p$ .
$V_{s,j(-)}$	Voltage drop in $R_s$ when a negative current is passed through $R_p$ .
$V_{off,j}$	Offset voltage drop in $R_s$ when current source is off.
$V_{p,j(+)}$	Voltage drop in $R_p$ when a positive current is passed through $R_p$ .
$V_{p,j(-)}$	Voltage drop in $R_p$ when a negative current is passed through $R_p$ .
$V_{pa,j(+)}$	Voltage drop in $R_{p,a}$ when a positive current is passed through $R_{p,a}$ .
$V_{pa,j(-)}$	Voltage drop in $R_{p,a}$ when a negative current is passed through $R_{p,a}$ .
$V_{pb,j(+)}$	Voltage drop in $R_{p,b}$ when a positive current is passed through $R_{p,b}$ .
$V_{pb,j(-)}$	Voltage drop in $R_{p,b}$ when a negative current is passed through $R_{p,b}$ .
$\delta_{Vratio}$	effect of linearity and short term stability of high resolution digital voltmeter, that measures voltage drop in $R_p$ , and $R_s$ using the same range for both readings. Its best estimation is zero.
$\delta_{centered}$	Centring error using a rod that suits perfectly converter hole is considered very small. Its best estimation is zero.

In the following tables the uncertainty budget is analyzed for each current and ratio polarity.

Quantity	Estimate	u(xi)	Probability distribution /method A or B	ci	u(Ri)	vi
Rp (ohms)	0,0009999135	1,39386E-08	Calibration uncertainty, drift, oil bath temperature and current dependency, normal	R/Rp	0,666671769	9,29E-09 infinite
Rs (ohms)	0,9999894	9,60955E-07	Calibration uncertainty, drift, oil bath temperature and current dependency, normal	R/Rs	6,66673E-04	6,41E-10 infinite
Vratio	0,666664702	3,99999E-06	Repeatability of Vratio, 10 measurements,method A, normal distribution	R/Vratio	1,00E-03	4,00E-09 9
δ Vratio	0	2,50000E-06	Linearity & short term stability of voltmeter, that measures voltage drop Rp, and Rs using same range, normal	R	6,66660E-04	1,67E-09 infinite
δ Vcentered	0	0	Centering error using a rod that suits perfectly converter hole is considered small, included in type A uncertainty	R	6,66666E-04	0,00E+00 infinite
R=	6,666660E-04					
				Combined standard uncertainty	1,0E-08	
Calibration at + 90 A				Effective degrees of freedom	>50	
				Expanded uncertainty (95% probability)	2,1E-08	

Quantity	Estimate	u(xi)	Probability distribution /method A or B	ci	u(Ri)	vi
Rp (ohms)	0,0009999135	1,39386E-08	Calibration uncertainty, drift, oil bath temperature and current dependency, normal	R/Rp	0,666671547	9,29E-09 infinite
Rs (ohms)	0,9999894	9,60955E-07	Calibration uncertainty, drift, oil bath temperature and current dependency, normal	R/Rs	6,66673E-04	6,41E-10 infinite
Vratio	0,66666448	3,99999E-06	Repeatability of Vratio, 10 measurements,method A, normal distribution	R/Vratio	1,00E-03	4,00E-09 9
δ Vratio	0	2,50000E-06	Linearity & short term stability of voltmeter, that measures voltage drop Rp, and Rs using same range, normal	R	6,66658E-04	1,67E-09 infinite
δ Vcentered	0	0	Centering error using a rod that suits perfectly converter hole is considered small, included in type A uncertainty	R	6,66666E-04	0,00E+00 infinite
R=	6,666658E-04					
				Combined standard uncertainty	1,0E-08	
Calibration at - 90 A				Effective degrees of freedom	>50	
				Expanded uncertainty (95% probability)	2,1E-08	

Quantity	Estimate	u(xi)	Probability distribution /method A or B	ci	u(Ri)	vi
Rp (ohms)	0,0009999135	1,39386E-08	Calibration uncertainty, drift, oil bath temperature and current dependency, normal	R/Rp	0,666671658	9,29E-09 infinite
Rs (ohms)	0,9999894	9,60955E-07	Calibration uncertainty, drift, oil bath temperature and current dependency, normal	R/Rs	6,66673E-04	6,41E-10 infinite
Vratio	0,666664591	3,99999E-06	Repeatability of Vratio, 10 measurements,method A, normal distribution	R/Vratio	1,00E-03	4,00E-09 9
δ Vratio	0	2,50000E-06	Linearity & short term stability of voltmeter, that measures voltage drop Rp, and Rs using same range, normal	R	6,66659E-04	1,67E-09 infinite
δ Vcentered	0	0	Centering error using a rod that suits perfectly converter hole is considered small, included in type A uncertainty	R	6,66666E-04	0,00E+00 infinite
R=	6,666659E-04					
				Combined standard uncertainty	1,0E-08	
Calibration at ± 90 A				Effective degrees of freedom	>50	
				Expanded uncertainty (95% probability)	2,1E-08	

Quantity	Estimate	u(xi)	Probability distribution /method A or B	ci	u(Ri)	vi
Rp (ohms)	0,0009999143	2,40872E-08	Calibration uncertainty, drift, oil bath temperature and current dependency, normal	R/Rp	0,666648381	1,61E-08 infinite
Rs (ohms)	0,9999894	9,60955E-07	Calibration uncertainty, drift, oil bath temperature and current dependency, normal	R/Rs	6,66650E-04	6,41E-10 infinite
Vratio	0,666641314	3,99985E-06	Repeatability of Vratio, 10 measurements,method A, normal distribution	R/Vratio	1,00E-03	4,00E-09 9
δ Vratio	0	2,50000E-06	Linearity & short term stability of voltmeter, that measures voltage drop Rp, and Rs using same range, normal	R	6,666427E-04	1,67E-09 infinite
δ Vcentered	0	0	Centering error using a rod that suits perfectly converter hole is considered small, included in type A uncertainty	R	6,66643E-04	0,00E+00 infinite
R=	6,666427E-04					
				Combined standard uncertainty	1,7E-08	
Calibration at + 300A				Effective degrees of freedom	>50	
				Expanded uncertainty (95% probability)	3,3E-08	

Quantity	Estimate	u(xi)	Probability distribution /method A or B	ci	u(Ri)	vi
Rp (ohms)	0,0009999143	2,40872E-08	Calibration uncertainty, drift, oil bath temperature and current dependency, normal	R/Rp	0,66664927	1,61E-08 infinite
Rs (ohms)	0,9999894	9,60955E-07	Calibration uncertainty, drift, oil bath temperature and current dependency, normal	R/Rs	6,66651E-04	6,41E-10 infinite
Vratio	0,666642203	3,99985E-06	Repeatability of Vratio, 10 measurements,method A, normal distribution	R/Vratio	1,00E-03	4,00E-09 9
δ Vratio	0	2,50000E-06	Linearity & short term stability of voltmeter, that measures voltage drop Rp, and Rs using same range, normal	R	6,666436E-04	1,67E-09 infinite
δ Vcentered	0	0	Centering error using a rod that suits perfectly converter hole is considered small, included in type A uncertainty	R	6,66644E-04	0,00E+00 infinite
R=	6,666436E-04					
				Combined standard uncertainty	1,7E-08	
Calibration at - 300 A				Effective degrees of freedom	>50	
				Expanded uncertainty (95% probability)	3,3E-08	

Quantity	Estimate	u(xi)	Probability distribution /method A or B	ci	u(Ri)	vi
Rp (ohms)	0,0009999143	2,40872E-08	Calibration uncertainty, drift, oil bath temperature and current dependency, normal	R/Rp	0,666648825	1,61E-08 infinite
Rs (ohms)	0,9999894	9,60955E-07	Calibration uncertainty, drift, oil bath temperature and current dependency, normal	R/Rs	6,66650E-04	6,41E-10 infinite
Vratio	0,666641759	3,99985E-06	Repeatability of Vratio, 10 measurements,method A, normal distribution	R/Vratio	1,00E-03	4,00E-09 9
δ Vratio	0	2,50000E-06	Linearity & short term stability of voltmeter, that measures voltage drop Rp, and Rs using same range, normal	R	6,666431E-04	1,67E-09 infinite
δ Vcentered	0	0	Centering error using a rod that suits perfectly converter hole is considered small, included in type A uncertainty	R	6,66643E-04	0,00E+00 infinite
R=	6,666431E-04					
				Combined standard uncertainty	1,7E-08	
Calibration at ± 300 A				Effective degrees of freedom	>50	
				Expanded uncertainty (95% probability)	3,3E-08	

Quantity	Estimate	u(xi)	Probability distribution /method A or B	ci	u(Ri)	vi	
Rp (ohms)	0,00099999143	2,40872E-08	Calibration uncertainty, drift, oil bath temperature and current dependency, normal	R/Rp	0,666648381	1,61E-08	infinite
Rs (ohms)	0,9999894	9,60955E-07	Calibration uncertainty, drift, oil bath temperature and current dependency, normal	R/Rs	6,66650E-04	6,41E-10	infinite
Vratio	0,666641314	3,99985E-06	Repeatability of Vratio, 10 measurements,method A, normal distribution	R/Vratio	1,00E-03	4,00E-09	9
δ Vratio	0	2,500000E-06	Linearity & short term stability of voltmeter, that measures voltage drop Rp, and Rs using same range, normal	R	6,666427E-04	1,67E-09	infinite
δ Vcentered	0	0	Centering error using a rod that suits perfectly converter hole is considered small, included in type A uncertainty	R	6,66643E-04	0,00E+00	infinite
R=	6,666427E-04						
				Combined standard uncertainty	1,7E-08		
Calibration at + 300A				Effective degrees of freedom	>50		
				Expanded uncertainty (95% probability)	3,3E-08		

Quantity	Estimate	u(xi)	Probability distribution /method A or B	ci	u(Ri)	vi	
Rp (ohms)	0,00099999143	2,40872E-08	Calibration uncertainty, drift, oil bath temperature and current dependency, normal	R/Rp	0,66664927	1,61E-08	infinite
Rs (ohms)	0,9999894	9,60955E-07	Calibration uncertainty, drift, oil bath temperature and current dependency, normal	R/Rs	6,66651E-04	6,41E-10	infinite
Vratio	0,666642203	3,99985E-06	Repeatability of Vratio, 10 measurements,method A, normal distribution	R/Vratio	1,00E-03	4,00E-09	9
δ Vratio	0	2,500000E-06	Linearity & short term stability of voltmeter, that measures voltage drop Rp, and Rs using same range, normal	R	6,666436E-04	1,67E-09	infinite
δ Vcentered	0	0	Centering error using a rod that suits perfectly converter hole is considered small, included in type A uncertainty	R	6,66644E-04	0,00E+00	infinite
R=	6,666436E-04						
				Combined standard uncertainty	1,7E-08		
Calibration at - 300 A				Effective degrees of freedom	>50		
				Expanded uncertainty (95% probability)	3,3E-08		

Quantity	Estimate	u(xi)	Probability distribution /method A or B	ci	u(Ri)	vi	
Rp (ohms)	0,00099999143	2,40872E-08	Calibration uncertainty, drift, oil bath temperature and current dependency, normal	R/Rp	0,666648825	1,61E-08	infinite
Rs (ohms)	0,9999894	9,60955E-07	Calibration uncertainty, drift, oil bath temperature and current dependency, normal	R/Rs	6,66650E-04	6,41E-10	infinite
Vratio	0,666641759	3,99985E-06	Repeatability of Vratio, 10 measurements,method A, normal distribution	R/Vratio	1,00E-03	4,00E-09	9
δ Vratio	0	2,500000E-06	Linearity & short term stability of voltmeter, that measures voltage drop Rp, and Rs using same range, normal	R	6,666431E-04	1,67E-09	infinite
δ Vcentered	0	0	Centering error using a rod that suits perfectly converter hole is considered small, included in type A uncertainty	R	6,66643E-04	0,00E+00	infinite
R=	6,666431E-04						
				Combined standard uncertainty	1,7E-08		
Calibration at ± 300 A				Effective degrees of freedom	>50		
				Expanded uncertainty (95% probability)	3,3E-08		

## 5. LNE – Laboratoire national de métrologie et d'essais (France)

### 5.1 Detailed uncertainty budget for measurements performed at 90 A

The value of the secondary to primary current ratio measured by means of the LNE standard resistances is given by the relation:

$$R = \frac{R_p}{R_s} + \frac{\Delta U}{R_s I_p} \quad (\text{Équation 6})$$

with:

$R_p$  - mean value of the standard resistance on the side of the primary current measured before and after its use;

$R_s$  - mean value of the standard resistance on the side of the secondary current measured before and after its use;

$\Delta U$  - measured voltage difference;

$I_p$  - primary current.  $I_p = \frac{U_{I_p}}{R_p}$

The sensitivity coefficients of the  $R = \frac{R_p}{R_s} + \frac{\Delta U}{R_s I_p}$  (Équation 6) are:

$$\frac{\partial R}{\partial(\Delta U)} = \frac{1}{R_s I_p} \quad (\text{Équation 7});$$

$$\frac{\partial R}{\partial R_p} = \frac{1}{R_s} \quad (\text{Équation 8});$$

$$\frac{\partial R}{\partial R_s} = -\left(1 + \frac{\Delta U}{R_p I_p}\right) \frac{R_p}{R_s^2} \quad (\text{Équation 9});$$

$$\frac{\partial R}{\partial I_p} = -\frac{\Delta U}{R_s I_p^2} \quad (\text{Équation 10}).$$

Taking into account the uncertainties components leads to the final relation of the combined uncertainty:

$$u_c(R) = \sqrt{\left(\frac{\partial R}{\partial(\Delta U)}\right)^2 u_c^2(\Delta U) + \left(\frac{\partial R}{\partial R_p}\right)^2 u_c^2(R_p) + \left(\frac{\partial R}{\partial R_s}\right)^2 u_c^2(R_s) + \left(\frac{\partial R}{\partial I_p}\right)^2 u_c^2(I_p)} \quad (\text{Équation 11})$$

A numerical example is provided for the uncertainty budget of current ratio measured at 90 A, positive polarity (*Table 1*), negative polarity (*Table 2*) and for the mean value of the current ratio (*Table 3*).

The uncertainty components related to the measured voltage difference  $\Delta U$  are:

- DMM calibration;
- Linearity of DMM;
- Instabilities of the measured voltage;
- Resolution of the DMM;
- Temperature effect;
- Drift between DMM calibrations;

The uncertainty components related to the standard resistances  $R_p$  (on the side of the primary current) and  $R_s$  (on the side of the secondary current) are:

- Resistance calibration;
- Standard deviation of measurements;
- Temperature effect;
- The effect of current flow;
- Drift between resistance calibrations.

The uncertainty components related to the standard resistances  $R_p$  (on the side of the primary current) and  $R_s$  (on the side of the secondary current) are:

- Resistance calibration;
- Standard deviation of measurements;
- Temperature effect;
- The effect of current flow;
- Drift between resistance calibrations.

The uncertainty components related to the primary current  $I_p$ . The value of the primary current is given

by:  $I_p = \frac{U_{I_p}}{R_{I_p}}$ . Therefore the combined uncertainty is :

$$\frac{u_c(I_p)}{I_p} = \sqrt{\frac{u_c^2(U_{I_p})}{U_{I_p}^2} + \frac{u_c^2(R_{I_p})}{R_{I_p}^2}} \quad (\text{Équation 12})$$

For each of the components: voltage measurement and resistance measurement, the uncertainty components are the same as listed before.

Table 1 The uncertainty budget of current ratio,  $R^+$ , measured at 90 A on 16/04/2013 is provided for positive polarity in the numerical example here after.

Quantity $X_i$	Estimate $x_i$	Standard uncertainty $u(x_i)$	Probability distribution /method of evaluation (A, B)	Sensitivity coefficient $c_i$	Uncertainty contribution $u(R_i)$	Degree of freedom $\nu$
$\Delta U$	$3.06 \times 10^{-6} \text{ V}$	$3.3 \times 10^{-8} \text{ V}$	Normal/B	$5.8 \times 10^{-3} \text{ V}^{-1}$	$1.9 \times 10^{-10}$	$\infty$
$R_p$ (mean value/day)	$0.00128723 \text{ } \Omega$	$7.7 \times 10^{-10} \text{ } \Omega$	Normal/A,B	$5.2 \times 10^{-1} \text{ } \Omega^{-1}$	$4.0 \times 10^{-10}$	54678.3
$R_s$ (mean value/day)	$1.93092989 \text{ } \Omega$	$1.3 \times 10^{-7} \text{ } \Omega$	Normal/A,B	$-3.5 \times 10^{-4} \text{ } \Omega^{-1}$	$-4.5 \times 10^{-11}$	$\infty$
$I_p$	$90.0007 \text{ A}$	$3.8 \times 10^{-2} \text{ A}$	Normal/B	$-2.0 \times 10^{-10} \text{ A}^{-1}$	$-7.3 \times 10^{-12}$	67697.7
<b><math>R^+</math></b>	<b><math>6.6665714 \times 10^{-4}</math></b>					
		<b>Combined standard uncertainty (k=1):</b>			<b><math>4.5 \times 10^{-10}</math></b>	
		<b>Effective degrees of freedom:</b>			<b>83994</b>	
		<b>Expanded uncertainty (95% coverage factor, k=2):</b>			<b><math>9.0 \times 10^{-10}</math></b>	

Table 2 The uncertainty budget of current ratio,  $R^-$ , measured at 90 A on 16/04/2013 is provided for negative polarity in the numerical example here after.

Quantity $X_i$	Estimate $x_i$	Standard uncertainty $u(x_i)$	Probability distribution /method of evaluation (A, B)	Sensitivity coefficient $c_i$	Uncertainty contribution $u(R_i)$	Degree of freedom $\nu$
$\Delta U$	$6.70 \times 10^{-6} \text{ V}$	$3.3 \times 10^{-8} \text{ V}$	Normal/B	$5.8 \times 10^{-3} \text{ V}^{-1}$	$1.9 \times 10^{-10}$	$\infty$
$R_p$ (mean value/day)	$0.00128723 \text{ } \Omega$	$7.7 \times 10^{-10} \text{ } \Omega$	Normal/A,B	$5.2 \times 10^{-1} \text{ } \Omega^{-1}$	$4.0 \times 10^{-10}$	54678.3
$R_s$ (mean value/day)	$1.93092989 \text{ } \Omega$	$1.3 \times 10^{-7} \text{ } \Omega$	Normal/A,B	$-3.5 \times 10^{-4} \text{ } \Omega^{-1}$	$-4.5 \times 10^{-11}$	$\infty$
$I_p$	$90.0007 \text{ A}$	$3.8 \times 10^{-2} \text{ A}$	Normal/B	$-4.3 \times 10^{-10} \text{ A}^{-1}$	$-1.6 \times 10^{-11}$	67697.7
<b><math>R^-</math></b>	<b><math>6.6667809 \times 10^{-4}</math></b>					
		<b>Combined standard uncertainty (k=1):</b>			<b><math>4.5 \times 10^{-10}</math></b>	
		<b>Effective degrees of freedom:</b>			<b>83994</b>	
		<b>Expanded uncertainty (95% coverage factor, k=2):</b>			<b><math>9.0 \times 10^{-10}</math></b>	

Table 3 The uncertainty budget of current ratio, the mean value,  $R_M$ , obtained from positive and negative polarities measured at 90 A on 16/04/2013.

Quantity $X_i$	Estimate $x_i$	Standard uncertainty $u(x_i)$	Probability distribution /method of evaluation (A, B)	Sensitivity coefficient $c_i$	Uncertainty contribution $u(R_i)$	Degree of freedom $\nu_i$
$R^+$	$6.6665714 \times 10^{-4}$	$4.5 \times 10^{-10}$	Normal/A,B	0.5	$2.2 \times 10^{-10}$	83994.0
$R^-$	$6.6667809 \times 10^{-4}$	$4.5 \times 10^{-10}$	Normal/A,B	0.5	$2.2 \times 10^{-10}$	83994.0
$R_M$	$6.6666761 \times 10^{-4}$					
		Combined standard uncertainty (k=1):			$3.2 \times 10^{-10}$	
		Effective degrees of freedom:			167988	
		Expanded uncertainty (95% coverage factor, k=2):			$6.4 \times 10^{-10}$	

### 5.1 Detailed uncertainty budget for measurements performed at 300 A and 600 A

The value of the secondary to primary current ratio measured by means of the LNE standard DC current transformer is given by the relation:

$$R = \frac{R_G}{R_L} \cdot \frac{k}{K_G}$$

with :

$R_G$  - Standard resistance on the side of the secondary current of Guildline DC current transformer

$R_L$  - Standard resistance on the side of the secondary current of LEM zero flux current transformer

$k$  - Measured voltage ratio

$K_G$  - Current ratio of the Guildline DC current transformer.

Applying the propagation law of the uncertainties, the following relation is obtained:

$$\frac{u_c(R)}{R} = \sqrt{\left(\frac{u_c(R_G)}{R_G}\right)^2 + \left(\frac{u_c(R_L)}{R_L}\right)^2 + \left(\frac{u_c(k)}{k}\right)^2 + \left(\frac{u_c(K_G)}{K_G}\right)^2} \quad (\text{Équation 13})$$

The uncertainty components related to the standard resistances  $R_G$  (on the side of Guildline DC current transformer) and  $R_L$  (on the side of LEM zero flux current transformer) are:

- Resistance calibration;
- Standard deviation of measurements;
- Temperature effect;
- The effect of current flow;
- Drift between resistance calibrations.

The uncertainty components related to the measured voltage ratio,  $k$  are:

- DMM calibration (ratio function);
- Linearity of the DMM;
- Instabilities of the measured voltage;
- Resolution of the DMM;
- Temperature effect;
- Drift between calibrations;

The uncertainty components related to the current ratio of the Guildline DC current transformer,  $K_G$  are:

- Current transformer calibration;
- Linearity with respect to current;
- Temperature effect;
- Drift between calibrations;

A numerical example is provided for the uncertainty budget of current ratio measured at 300 A, positive polarity (*Table 4*), negative polarity (*Table 5*) and for the mean value of the current ratio (*Table 6*).

Table 4 The uncertainty budget of current ratio,  $R^+$ , measured at 300 A on 23/04/2013 is provided for positive polarity in the numerical example here after.

Quantity $X_i$	Estimate $x_i$	Standard uncertainty $u(x_i)$	Probability distribution /method of evaluation (A, B)	Sensitivity coefficient $c_i$	Uncertainty contribution $u(R_i)$	Degree of freedom $\nu_i$
$R_G$	1.00007571 $\Omega$	$6.08 \times 10^{-8}$	Normal/A,B	$6.7 \times 10^{-4}$	$4.05 \times 10^{-11}$	$3.5 \times 10^4$
$R_L$	2.00092396 $\Omega$	$1.93 \times 10^{-7}$	Normal/A,B	$3.3 \times 10^{-4}$	$6.42 \times 10^{-11}$	$2.0 \times 10^4$
k	1.3339040	$2.81 \times 10^{-6}$	Normal/A,B	$5.0 \times 10^{-4}$	$1.41 \times 10^{-9}$	4.23
$K_G$	999.9972	$3.50 \times 10^{-3}$	Normal/B	$6.7 \times 10^{-7}$	$2.33 \times 10^{-9}$	$\infty$
$R^+$	<b><math>6.666964 \times 10^{-4}</math></b>					
Combined standard uncertainty (k=1):					<b><math>2.7 \times 10^{-9}</math></b>	
Effective degrees of freedom:					<b>60</b>	
Expanded uncertainty (95% coverage factor, k=2):					<b><math>5.5 \times 10^{-9}</math></b>	

Table 5 The uncertainty budget of current ratio,  $R^-$ , measured at 300 A on 23/04/2013 is provided for negative polarity in the numerical example here after.

Quantity $X_i$	Estimate $x_i$	Standard uncertainty $u(x_i)$	Probability distribution /method of evaluation (A, B)	Sensitivity coefficient $c_i$	Uncertainty contribution $u(R_i)$	Degree of freedom $\nu_i$
$R_G$	1.00007571 $\Omega$	$6.08 \times 10^{-8}$	Normal/A,B	$6.7 \times 10^{-4}$	$4.05 \times 10^{-11}$	$3.5 \times 10^4$
$R_L$	2.00092396 $\Omega$	$1.93 \times 10^{-7}$	Normal/A,B	$3.3 \times 10^{-4}$	$6.42 \times 10^{-11}$	$2.0 \times 10^4$
k	1.3337949	$9.30 \times 10^{-7}$	Normal/A,B	$5.0 \times 10^{-4}$	$4.67 \times 10^{-10}$	5.31
$K_G$	999.9972	$3.50 \times 10^{-3}$	Normal/B	$6.7 \times 10^{-7}$	$2.33 \times 10^{-9}$	$\infty$
$R^-$	<b><math>6.666418 \times 10^{-4}</math></b>					
Combined standard uncertainty (k=1):					<b><math>2.4 \times 10^{-9}</math></b>	
Effective degrees of freedom:					<b>3588</b>	
Expanded uncertainty (95% coverage factor, k=2):					<b><math>4.8 \times 10^{-9}</math></b>	

Table 6 The uncertainty budget of current ratio, the mean value,  $R_M$ , obtained from positive and negative polarities measured at 300 A on 23/04/2013.

Quantity $X_i$	Estimate $x_i$	Standard uncertainty $u(x_i)$	Probability distribution /method of evaluation (A, B)	Sensitivity coefficient $c_i$	Uncertainty contribution $u(R_i)$	Degree of freedom $\nu_i$
$R^+$	<b><math>6.666964 \times 10^{-4}</math></b>	<b><math>2.7 \times 10^{-9}</math></b>	Normal/A,B	0.5	$1.4 \times 10^{-9}$	59.7
$R^-$	<b><math>6.666418 \times 10^{-4}</math></b>	<b><math>2.4 \times 10^{-9}</math></b>	Normal/A,B	0.5	$1.2 \times 10^{-9}$	3587.5
$R_M$	<b><math>6.66691 \times 10^{-4}</math></b>					
Combined standard uncertainty (k=1):					<b><math>1.8 \times 10^{-9}</math></b>	
Effective degrees of freedom:					<b>184</b>	
Expanded uncertainty (95% coverage factor, k=2):					<b><math>3.6 \times 10^{-9}</math></b>	

A numerical example is provided for the uncertainty budget of current ratio measured at 600 A, positive polarity (Table 7), negative polarity (Table 8) and for the mean value of the current ratio (Table 9).

Table 7 The uncertainty budget of current ratio,  $R^+$ , measured at 600 A on 23/04/2013 is provided for positive polarity in the numerical example here after.

Quantity $X_i$	Estimate $x_i$	Standard uncertainty $u(x_i)$	Probability distribution /method of evaluation (A, B)	Sensitivity coefficient $c_i$	Uncertainty contribution $u(R_i)$	Degree of freedom $\nu_i$
$R_G$	1.00007854 $\Omega$	$6.3 \times 10^{-8}$	Normal/A,B	$6.7 \times 10^{-4}$	$4.2 \times 10^{-11}$	$1.5 \times 10^3$
$R_L$	2.00093840 $\Omega$	$1.9 \times 10^{-7}$	Normal/A,B	$3.3 \times 10^{-4}$	$6.4 \times 10^{-11}$	$2.2 \times 10^4$
$k$	1.3339100	$1.3 \times 10^{-5}$	Normal/A,B	$5.0 \times 10^{-4}$	$6.4 \times 10^{-9}$	6.04
$K_G$	999.9972	$6.8 \times 10^{-3}$	Normal/B	$6.7 \times 10^{-7}$	$4.5 \times 10^{-9}$	$\infty$
$R^+$	<b><math>6.666964 \times 10^{-4}</math></b>					
<b>Combined standard uncertainty (k=1):</b>					<b><math>7.9 \times 10^{-9}</math></b>	
<b>Effective degrees of freedom:</b>					<b>13</b>	
<b>Expanded uncertainty (k=2):</b>					<b><math>1.6 \times 10^{-8}</math></b>	

Table 8 The uncertainty budget of current ratio,  $R^-$ , measured at 600 A on 23/04/2013 is provided for negative polarity in the numerical example here after.

Quantity $X_i$	Estimate $x_i$	Standard uncertainty $u(x_i)$	Probability distribution /method of evaluation (A, B)	Sensitivity coefficient $c_i$	Uncertainty contribution $u(R_i)$	Degree of freedom $\nu_i$
$R_G$	1.00007854 $\Omega$	$6.3 \times 10^{-8}$	Normal/A,B	$6.7 \times 10^{-4}$	$4.2 \times 10^{-11}$	$1.5 \times 10^3$
$R_L$	2.00093840 $\Omega$	$1.9 \times 10^{-7}$	Normal/A,B	$3.3 \times 10^{-4}$	$6.4 \times 10^{-11}$	$2.2 \times 10^4$
$k$	1.3338302	$1.2 \times 10^{-5}$	Normal/A,B	$5.0 \times 10^{-4}$	$5.9 \times 10^{-9}$	7.1
$K_G$	999.9972	$6.8 \times 10^{-3}$	Normal/B	$6.7 \times 10^{-7}$	$4.5 \times 10^{-9}$	$\infty$
$R^-$	<b><math>6.666565 \times 10^{-4}</math></b>					
<b>Combined standard uncertainty (k=1):</b>					<b><math>7.4 \times 10^{-9}</math></b>	
<b>Effective degrees of freedom:</b>					<b>18</b>	
<b>Expanded uncertainty (k=2):</b>					<b><math>1.5 \times 10^{-8}</math></b>	

Table 9 The uncertainty budget of current ratio, the mean value,  $R_M$ , obtained from positive and negative polarities measured at 600 A on 23/04/2013.

Quantity $X_i$	Estimate $x_i$	Standard uncertainty $u(x_i)$	Probability distribution /method of evaluation (A, B)	Sensitivity coefficient $c_i$	Uncertainty contribution $u(R_i)$	Degree of freedom $\nu_i$
$R^+$	<b><math>6.666964 \times 10^{-4}</math></b>	<b><math>7.9 \times 10^{-9}</math></b>	Normal/A,B	0.5	$3.9 \times 10^{-9}$	13.4
$R^-$	<b><math>6.666565 \times 10^{-4}</math></b>	<b><math>7.4 \times 10^{-9}</math></b>	Normal/A,B	0.5	$3.7 \times 10^{-9}$	17.8
$R_M$	<b><math>6.666765 \times 10^{-4}</math></b>					
<b>Combined standard uncertainty (k=1):</b>					<b><math>5.4 \times 10^{-9}</math></b>	
<b>Effective degrees of freedom:</b>					<b>30</b>	
<b>Expanded uncertainty (k=2):</b>					<b><math>1.1 \times 10^{-8}</math></b>	

**Current ratio in relation to the current level**

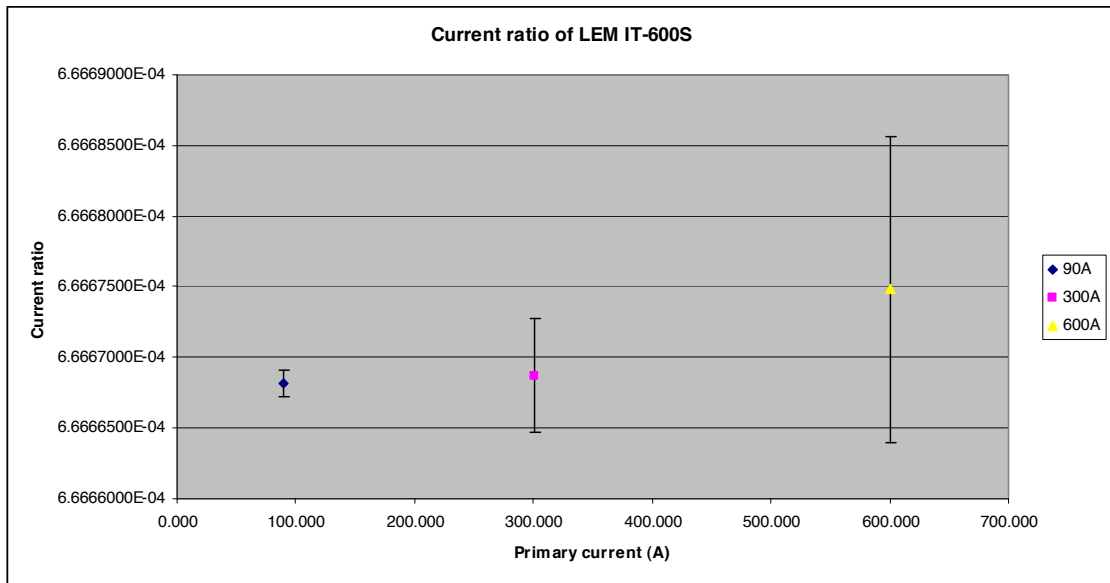

**Measurements at 90 A**

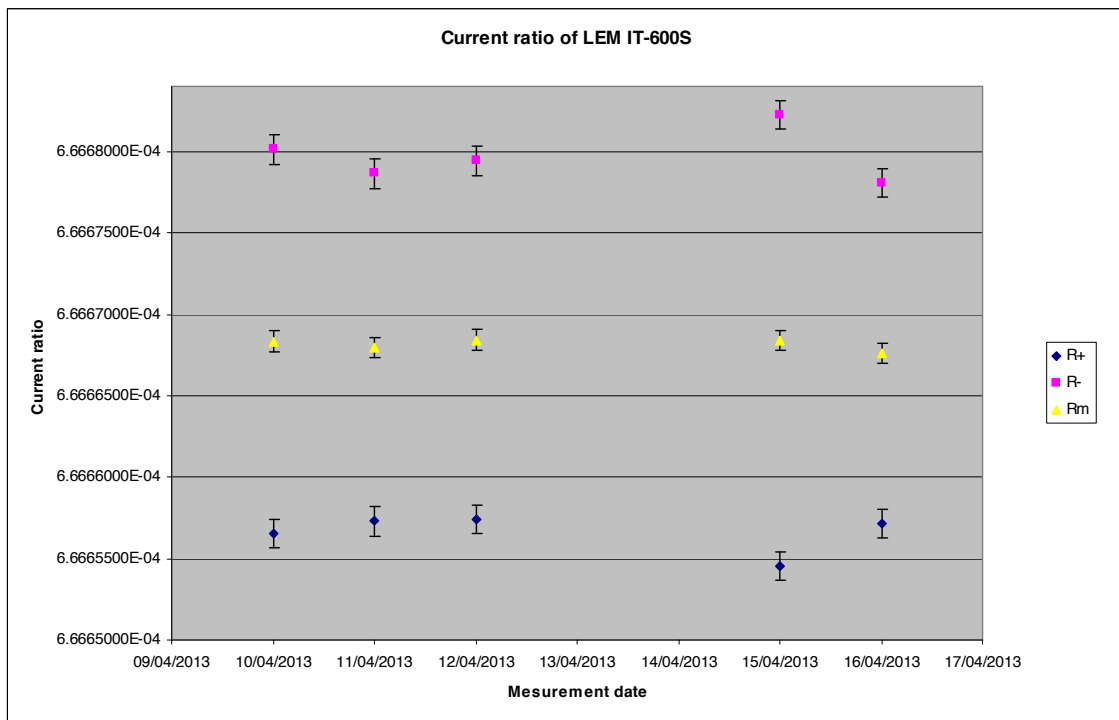

**Measurements at 300 A**

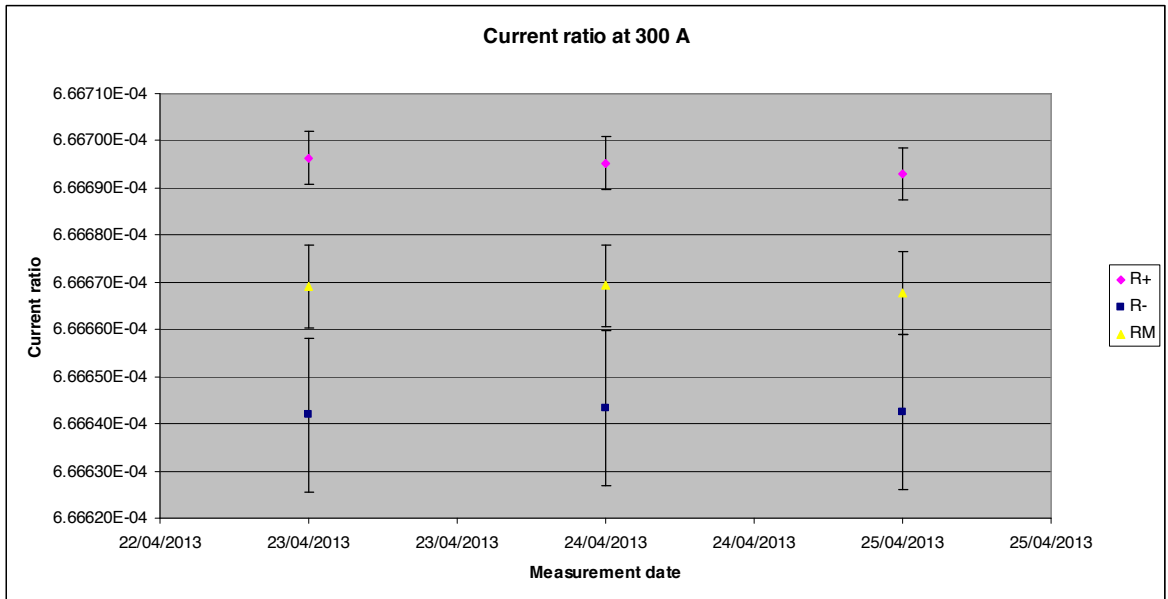

**Measurements at 600 A**

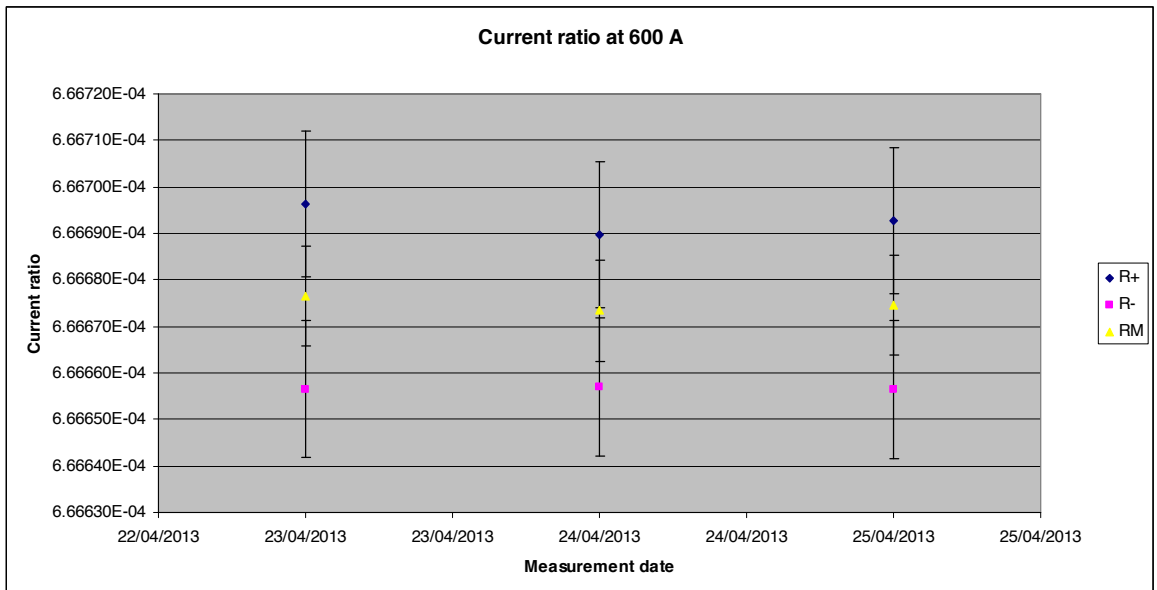

## 6. METAS – Federal Institute of Metrology METAS (Switzerland)

### 6.1 Detailed uncertainty budget

#### Loop 1: Positive currents

Current = 90 A					DOF	
		Unit	Dist., Eval.	u (ppm)		
Reference resistor 10 ohm	1.0	ppm	norm, A	1.0	∞	
Reference resistor 1 ohm	0.3	ppm	norm, A	0.3	∞	
Voltage meas. Vs (1-V-range)	0.8	ppm	norm, B	0.8	∞	
Voltage meas. Vx (100-mV-range)	0.6	ppm	norm, B	0.6	∞	
Ratio MI 6011 (ratio + linearity)	0.1	ppm	norm, B	0.1	∞	
Reproducibility Ux/Us meas.	0.3	ppm	norm, A	0.3	15	
Offset stability reference DCCT (100 A/V)	0.03	µV	norm, A	0.03	30	
Offset stability DUT (1500 A/V)	0.03	µV	norm, A	0.4	30	
Combined standard uncertainty				1.5	eff. DOF	45
U-95				3.1	cov. fact.	2.02

Current = 300 A					DOF	
		Unit	Dist., Eval.	u (ppm)		
Calibration DCCT	1.4	ppm	norm, A	1.4	∞	
Reference resistor 1 ohm	0.3	ppm	norm, A	0.3	∞	
Voltage meas. Vs (10-V-range)	0.3	ppm	norm, B	0.3	∞	
Voltage meas. Vx (1-V-range)	0.5	ppm	norm, B	0.5	∞	
Reproducibility Ux/Us meas.	0.2	ppm	norm, A	0.2	15	
Offset stability reference DCCT (30 A/V)	0.5	µV	norm, A	0.1	30	
Offset stability DUT (1500 A/V)	0.03	µV	norm, A	0.2	30	
Combined standard uncertainty				1.5	eff. DOF	43
U-95				3.1	cov. fact.	2.02

Current = 600 A					DOF	
		Unit	Dist., Eval.	u (ppm)		
Calibration DCCT	1.7	ppm	norm, A	1.7	∞	
Reference resistor 1 ohm	0.3	ppm	norm, A	0.3	∞	
Voltage meas. Vs (10-V-range)	0.3	ppm	norm, B	0.3	∞	
Voltage meas. Vx (10-V-range)	0.3	ppm	norm, B	0.3	∞	
Reproducibility Ux/Us meas.	0.4	ppm	norm, A	0.4	15	
Offset stability reference DCCT (100 A/V)	0.4	µV	norm, A	0.1	30	
Offset stability DUT (1500 A/V)	0.03	µV	norm, A	0.1	30	
Combined standard uncertainty				1.8	eff. DOF	17
U-95				3.8	cov. fact.	2.11

#### Negative currents:

It has been observed at negative currents that the unit under test has non-negligible temperature effects that cannot simply be described by a temperature coefficient with the temperature measured outside the device. This gives rise to an additional uncertainty component present in the negative current measurements only.

Current = -90 A					DOF	
		Unit	Dist., Eval.	u (ppm)		
Reference resistor 10 ohm	1.0	ppm	norm, A	1.0	∞	
Reference resistor 1 ohm	0.3	ppm	norm, A	0.3	∞	
Voltage meas. Vs (1-V-range)	0.8	ppm	norm, B	0.8	∞	
Voltage meas. Vx (100-mV-range)	0.6	ppm	norm, B	0.6	∞	
Ratio MI 6011 (ratio + linearity)	0.1	ppm	norm, B	0.1	∞	
Reproducibility Ux/Us meas.	0.3	ppm	norm, A	0.3	15	
Offset stability reference DCCT (100 A/V)	0.03	µV	norm, A	0.03	30	
Offset stability DUT (1500 A/V)	0.03	µV	norm, A	0.4	30	
Unaccounted temperature effects	0.80	ppm	rect, B	0.8	∞	
Combined standard uncertainty				1.7	eff. DOF	45
U-95				3.5	cov. fact.	2.02

<b>Current = -300 A</b>		Unit	Dist., Eval.	u (ppm)
Calibration DCCT	1.4	ppm	norm, A	1.4
Reference resistor 1 ohm	0.3	ppm	norm, A	0.3
Voltage meas. Vs (10-V-range)	0.3	ppm	norm, B	0.3
Voltage meas. Vx (1-V-range)	0.5	ppm	norm, B	0.5
Reproducibility Ux/Us meas.	0.2	ppm	norm, A	0.2
Offset stability reference DCCT (30 A/V)	0.5	µV	norm, A	0.1
Offset stability DUT (1500 A/V)	0.03	µV	norm, A	0.2
Unaccounted temperature effects	1.50	ppm	rect, B	1.5
Combined standard uncertainty				2.2
U-95				4.4

<b>DOF</b>	
∞	
∞	
∞	
∞	
∞	
15	
30	
30	
∞	
eff. DOF	43
cov. fact.	2.02

<b>Current = -600 A</b>		Unit	Dist., Eval.	u (ppm)
Calibration DCCT	1.7	ppm	norm, A	1.7
Reference resistor 1 ohm	0.3	ppm	norm, A	0.3
Voltage meas. Vs (10-V-range)	0.3	ppm	norm, B	0.3
Voltage meas. Vx (10-V-range)	0.3	ppm	norm, B	0.3
Reproducibility Ux/Us meas.	0.4	ppm	norm, A	0.4
Offset stability reference DCCT (100 A/V)	0.4	µV	norm, A	0.1
Offset stability DUT (1500 A/V)	0.03	µV	norm, A	0.1
Unaccounted temperature effects	1.50	ppm	rect, B	1.5
Combined standard uncertainty				2.3
U-95				4.9

<b>DOF</b>	
∞	
∞	
∞	
∞	
∞	
15	
30	
30	
∞	
eff. DOF	17
cov. fact.	2.11

**Loop 2:** Method 1

<b>Reference MI 6011 (90 A)</b>		Unit	Dist., Eval.	u (ppm)
Reference resistor 10 ohm	0.3	ppm	norm, A	0.3
Reference resistor 1 ohm	0.3	ppm	norm, A	0.3
Voltage meas. Vs (1-V-range)	0.3	ppm	norm, B	0.3
Voltage meas. Vx (100-mV-range)	0.3	ppm	norm, B	0.3
Ratio MI 6011 (ratio + linearity)	0.1	ppm	norm, B	0.1
Reproducibility Ux/Us meas.	0.3	ppm	norm, A	0.3
Offset stability Reference DCCT (100 A/V)	0.03	µV	norm, A	0.03
Offset stability DUT (1500 A/V)	0.03	µV	norm, A	0.4
Combined standard uncertainty				0.8
U-95				1.6

<b>DOF</b>	
∞	
∞	
∞	
∞	
∞	
∞	
15	
30	
30	
eff. DOF	45
cov. fact.	2.02

<b>Reference Hitec 300 (300 A)</b>		Unit	Dist., Eval.	u (ppm)
Calibration DCCT	0.7	ppm	norm, A	0.7
Reference resistor 1 ohm	0.3	ppm	norm, A	0.3
Voltage meas. Vs (10-V-range)	0.3	ppm	norm, B	0.3
Voltage meas. Vx (1-V-range)	0.3	ppm	norm, B	0.3
Reproducibility Ux/Us meas.	0.3	ppm	norm, A	0.3
Offset stability Reference DCCT (30 A/V)	0.5	µV	norm, A	0.1
Offset stability DUT (1500 A/V)	0.03	µV	norm, A	0.2
Combined standard uncertainty				0.9
U-95				2.0

<b>DOF</b>	
∞	
∞	
∞	
∞	
∞	
15	
30	
30	
eff. DOF	24
cov. fact.	2.06

Reference Hitec 1000 (600 A)		Unit	Dist., Eval.	u (ppm)	DOF
Calibration DCCT	0.9	ppm	norm, A	0.9	∞
Reference resistor 1 ohm	0.3	ppm	norm, A	0.3	∞
Voltage meas. Vs (10-V-range)	0.3	ppm	norm, B	0.3	∞
Voltage meas. Vx (10-V-range)	0.3	ppm	norm, B	0.3	∞
Reproducibility Ux/Us meas.	0.3	ppm	norm, A	0.3	15
Offset stability Reference DCCT (100 A/V)	0.5	μV	norm, A	0.1	30
Offset stability DUT (1500 A/V)	0.03	μV	norm, A	0.1	30
Combined standard uncertainty					1.1
U-95					2.3

eff. DOF	19
cov. fact.	2.09

**Method 2**

Measurement with MI 6010 + 6011 range extender	Dist., Eval.	u (ppm)
Ratio error range extender	rectangular,B	0.2
Detector gain	rectangular,B	0.1
Ratio error 6010 bridge	norm, A	0.05
Reference standard	norm, A	0.1
UUT burden resistor	norm, A	0.1
Type A uncertainty, measurement	norm, A	0.1
Uncompensated offsets	rectangular,B	0.3
Combined standard uncertainty	0.4	
U-95	0.7	

For this method, the degrees of freedom are infinite for all practical purposes.

**6.2 Uncertainty of measurement**

**Loop 1:**

The reported uncertainty of measurement is stated as the combined standard uncertainty multiplied by the appropriate coverage factor. The measured value ( $y$ ) and the associated expanded uncertainty ( $U$ ) represent the interval ( $y \pm U$ ) which contains the value of the measured quantity with a probability of approximately 95 %. The uncertainty was estimated following the guidelines of the ISO (GUM:1995).

The measurement uncertainty contains contributions originating from the measurement standard, from the calibration method, from the environmental conditions and from the object being calibrated. The long-term characteristic of the object being calibrated is not included.

**Loop 2:**

The reported uncertainty of measurement is stated as the combined standard uncertainty multiplied by the appropriate coverage factor. The measured value ( $y$ ) and the associated expanded uncertainty ( $U$ ) represent the interval ( $y \pm U$ ) which contains the value of the measured quantity with a probability of approximately 95 %. The uncertainty was estimated following the guidelines of the ISO (GUM:1995).

The measurement uncertainty contains contributions originating from the measurement standard, from the calibration method, from the environmental conditions and from the object being calibrated. The long-term characteristic of the object being calibrated is not included.

## 7. MIKES – Centre for Metrology and Accreditation (Finland)

### 7.1 Measurement uncertainty

#### Description of the uncertainty components

##### Voltages $U_S$ , $U_{S-off}$ , $U_P$ and $U_{P-off}$

Quantities  $U_S$ ,  $U_{S-off}$ ,  $U_P$  and  $U_{P-off}$  are voltages measured by the DMMs. The estimates are averages of the voltages corrected by the calibration factors of the DMMs. The uncertainties are derived from calibration uncertainties of the DMMs. For example in table 1 the DMMs were set on 100 mV range and their calibration uncertainties at 100 mV were 6.5 ppm ( $k=2$ ) and 10.3 ppm ( $k=2$ ). These values include also typical drifts over 1 or 2 years calibration intervals. The measured voltages in table 1 are roughly 60 mV, -0.003 mV, 11.25 mV and 0.001 mV. Using the same relative uncertainties, for example of 3.25 ppm ( $k=1$ ) for 0.001 mV gives very low absolute uncertainty of about 3 pV but it must be emphasized that it represents only the gain uncertainty of the DMM 100 mV range. Constant parts of the offset errors of the DMMs and the setup are cancelled when the differences  $U_S - U_{S-off}$  and  $U_P - U_{P-off}$  are calculated. The type A uncertainties of the voltage measurements are included in the quantity  $r$  which is explained later.

##### Resistances $R_S$ and $R_P$

The calibration uncertainty, current dependency, drift after calibration, and the effects of ambient temperature for the resistance values were studied when estimating the total uncertainty of reference resistance.

##### Current dependency

All resistors were calibrated with several current values covering the ranges needed in this comparison so that it was possible to calculate a second order model for the resistance as the function of the applied current. This model was then used to calculate the resistance for any current used in the measurements.

##### Drift

All resistors were calibrated within few weeks or months before the comparison measurements and they also had older calibration history which could be used to estimate the possible drifts after calibrations. Based on this information drift corrections or additional uncertainties were not considered necessary.

##### Ambient temperature

For the resistors there was no direct information about the temperature dependency of the resistance values. On the other hand all resistors had low current and power dependencies even though the applied powers of several watts caused several degrees of temperature rise in the resistor elements. This insensitivity for heat generated by the applied current implies also insensitivity for the ambient temperature changes. This argument should be valid for the resistors on primary current where the self-heating was high enough to reveal any significant sensitivity for temperature.

For the 1  $\Omega$  shunt on the secondary current loop the self-heating was lower and the low temperature coefficient had to be verified other way. Some of the measurements were done by placing the 1  $\Omega$  shunt on the floor where the ambient temperature was 22.5 °C and some of the measurements were done by placing the 1  $\Omega$  shunt on top of the warm surface of the DMM on the table. There was no noticeable effect on calibration results. This indicated that the temperature coefficient of the 1  $\Omega$  shunt was also low enough so that the calibration results from certificate M-13E201 corresponding to 22.86 °C ambient temperature could be used without any additional uncertainty based on ambient conditions.

In summary, no additional uncertainty based on ambient conditions was used for any of the resistors. The relative uncertainties used for the resistance values were 1.4 ppm ( $k=2$ ) for the 1  $\Omega$  shunt, 2.13 ppm ( $k=2$ ) for the 10 m $\Omega$  shunt and 4.05 ppm ( $k=2$ ) for the 1 m $\Omega$  shunt.

##### Current ratio noise $r$

The measured voltages had quite significant variation mainly because of the heating, noise and instability of the currents sources. Settling of the voltages took typically 10 minutes or more. The voltage ratio instead was stabilized much faster. The quantity  $r$  with value 1 was added to the uncertainty budget. Standard error of the mean was used as the uncertainty of  $r$ . It represents the type A uncertainty of measured voltage ratio.

##### Reproducibility $c$

Some of the measurements were clearly erroneous and gave results which deviated tens or even hundreds of ppms from typical results. Sometimes the reason was obvious, such as nonsymmetrical winding of the primary conductor or unreliable connection in some point of the setup. Sometimes only some component of the results (positive, negative or zero) was deviating without a clear reason.

In some measurements where zero current was measured more than once there were one or more periods which gave "correct" results and others that gave clearly deviating results. These results could have been used after removing the deviating parts but this kind of tendentious selection of the data was not considered acceptable and the entire measurement was abandoned.

Most of the measurements of the first days were abandoned because the importance of the symmetrical primary windings and the possible effect of the position of the travelling standard were not yet discovered and these features of the measurements were not documented. Some of these measurements of the first days were also not even intended to be actual comparison measurements but they were just preliminary testing of the different setups, current sources, reference resistors, settling times and other features and these results were also abandoned from the final results.

After abandoning the results mentioned above the following number of independent measurements remained: five  $\pm 90$  A measurements, six  $\pm 300$  A measurements and six  $\pm 600$  A measurements. The day to day deviation of these remaining results was still larger than the known uncertainty sources combined. Thus the quantity  $c$  with value 1 representing the reproducibility was added to the uncertainty budget. Standard error of the mean was used as the uncertainty of  $r$ . This reproducibility is calculated only from 5 or 6 observations so it has low degrees of freedom. Because it is one of the largest sources of the uncertainty it decreases the total effective degrees of freedom and coverage factors larger than 2 must be used in some cases to reach a coverage probability of 95 %.

Table 1: Uncertainty budget for +90 A nominal primary current  $R_+$ .

Quantity	Estimate	Standard uncertainty	Probability distribution / method of evaluation (A, B)	Sensitivity coefficient	Uncertainty contribution	Degree of freedom
$X_i$	$x_i$	$u(x_i)$		$c_i$	$u(R_i)$	$\nu_i$
$U_{\pm}$	0.059985	3.10E-07	normal / B	1.11E-02	3.44E-09	9.00E+99
$U_{\pm-off}$	-0.000003	1.75E-11	normal / B	-1.11E-02	-1.94E-13	9.00E+99
$U_p$	0.0112503	3.65E-08	normal / B	-5.93E-02	-2.16E-09	9.00E+99
$U_{p-off}$	0.0000010	3.11E-12	normal / B	5.93E-02	1.85E-13	9.00E+99
$R_s$	0.999864168	7.00E-07	normal / B	-6.67E-04	-4.67E-10	9.00E+99
$R_p$	0.000999988	2.02E-09	normal / B	6.67E-01	1.35E-09	9.00E+99
$r$	1	1.74E-07	normal / A	6.67E-04	1.16E-10	719
$c$	1	1.23E-06	normal / A	6.67E-04	8.18E-10	7
$N$	8	0				
$R_+$	6.6665990E-04					
<b>Total Type A uncertainty</b>					8.3E-10	
<b>Total Type B uncertainty</b>					4.3E-09	
<b>Combined standard uncertainty</b>					4.4E-09	
<b>Effective degrees of freedom</b>					5800	
<b>Value of coverage factor k</b>					2	
<b>Expanded uncertainty (95 % coverage factor)</b>					8.8E-09	

Table 2: Uncertainty budget for -90 A nominal primary current  $R_-$ .

Quantity	Estimate	Standard uncertainty	Probability distribution / method of evaluation (A, B)	Sensitivity coefficient	Uncertainty contribution	Degree of freedom
$X_i$	$x_i$	$u(x_i)$		$c_i$	$u(R_i)$	$\nu_i$
$U_{\pm}$	-0.059988	3.10E-07	normal / B	-1.11E-02	-3.44E-09	9.00E+99
$U_{\pm-off}$	-0.000003	1.75E-11	normal / B	1.11E-02	1.94E-13	9.00E+99
$U_p$	-0.0112476	3.65E-08	normal / B	5.93E-02	2.16E-09	9.00E+99
$U_{p-off}$	0.0000010	3.11E-12	normal / B	-5.93E-02	-1.85E-13	9.00E+99
$R_s$	0.999864168	7.00E-07	normal / B	-6.67E-04	-4.67E-10	9.00E+99
$R_p$	0.000999988	2.02E-09	normal / B	6.67E-01	1.35E-09	9.00E+99
$r$	1	1.74E-07	normal / A	6.67E-04	1.16E-10	719
$c$	1	3.20E-06	normal / A	6.67E-04	2.13E-09	7
$N$	8	0				
$R_-$	6.6665843E-04					
<b>Total Type A uncertainty</b>					2.1E-09	
<b>Total Type B uncertainty</b>					4.3E-09	
<b>Combined standard uncertainty</b>					4.8E-09	
<b>Effective degrees of freedom</b>					182	
<b>Value of coverage factor k</b>					2	
<b>Expanded uncertainty (95 % coverage factor)</b>					9.6E-09	

Table 3: Uncertainty budget for the mean  $R_M$  of +90 A and -90 A nominal primary currents.

Quantity	Estimate	Standard uncertainty	Probability distribution / method of evaluation (A, B)	Sensitivity coefficient	Uncertainty contribution	Degree of freedom
$X_i$	$x_i$	$u(x_i)$		$c_i$	$u(R_j)$	$\nu_i$
$U_S$	0.059986	3.10E-07	normal / B	1.11E-02	3.44E-09	9.00E+99
$U_{S-off}$	0.000000	1.75E-11	normal / B	-1.11E-02	-1.94E-13	9.00E+99
$U_P$	0.0112490	3.65E-08	normal / B	-5.93E-02	-2.16E-09	9.00E+99
$U_{P-off}$	0.0000000	3.11E-12	normal / B	5.93E-02	1.85E-13	9.00E+99
$R_S$	0.999864168	7.00E-07	normal / B	-6.67E-04	-4.67E-10	9.00E+99
$R_P$	0.000999988	2.02E-09	normal / B	6.67E-01	1.35E-09	9.00E+99
$r$	1	1.74E-07	normal / A	6.67E-04	1.16E-10	719
$c$	1	1.94E-06	normal / A	6.67E-04	1.29E-09	7
$N$	8	0				
$R_M$	6.6665916E-04					
<b>Total Type A uncertainty</b>					1.3E-09	
<b>Total Type B uncertainty</b>					4.3E-09	
<b>Combined standard uncertainty</b>					4.5E-09	
<b>Effective degrees of freedom</b>					1037	
<b>Value of coverage factor k</b>					2	
<b>Expanded uncertainty (95 % coverage factor)</b>					9.0E-09	

Table 4: Uncertainty budget for +300 A nominal primary current  $R_+$ .

Quantity	Estimate	Standard uncertainty	Probability distribution / method of evaluation (A, B)	Sensitivity coefficient	Uncertainty contribution	Degree of freedom
$X_i$	$x_i$	$u(x_i)$		$c_i$	$u(R_j)$	$\nu_i$
$U_S$	0.200118	2.96E-07	normal / B	3.33E-03	9.87E-10	9.00E+99
$U_{S-off}$	0.000003	4.49E-12	normal / B	-3.33E-03	-1.49E-14	9.00E+99
$U_P$	0.0375267	3.90E-08	normal / B	-1.78E-02	-6.92E-10	9.00E+99
$U_{P-off}$	0.0000001	9.96E-14	normal / B	1.78E-02	1.77E-15	9.00E+99
$R_S$	0.999864168	7.00E-07	normal / B	-6.67E-04	-4.67E-10	9.00E+99
$R_P$	0.000999986	2.02E-09	normal / B	6.67E-01	1.35E-09	9.00E+99
$r$	1	1.74E-07	normal / A	6.67E-04	1.16E-10	809
$c$	1	1.48E-06	normal / A	6.67E-04	9.86E-10	6
$N$	8	0				
$R_+$	6.6665716E-04					
<b>Total Type A uncertainty</b>					9.9E-10	
<b>Total Type B uncertainty</b>					1.9E-09	
<b>Combined standard uncertainty</b>					2.1E-09	
<b>Effective degrees of freedom</b>					127	
<b>Value of coverage factor k</b>					2	
<b>Expanded uncertainty (95 % coverage factor)</b>					4.2E-09	

Table 5: Uncertainty budget for -300 A nominal primary current  $R_-$ .

Quantity	Estimate	Standard uncertainty	Probability distribution / method of evaluation (A, B)	Sensitivity coefficient	Uncertainty contribution	Degree of freedom
$X_i$	$x_i$	$u(x_i)$		$c_i$	$u(R_j)$	$\nu_i$
$U_S$	-0.199969	2.96E-07	normal / B	-3.33E-03	-9.87E-10	9.00E+99
$U_{S-off}$	0.000003	4.49E-12	normal / B	3.33E-03	1.50E-14	9.00E+99
$U_P$	-0.0374988	3.89E-08	normal / B	1.78E-02	6.92E-10	9.00E+99
$U_{P-off}$	0.0000001	9.96E-14	normal / B	-1.78E-02	-1.77E-15	9.00E+99
$R_S$	0.999864168	7.00E-07	normal / B	-6.67E-04	-4.67E-10	9.00E+99
$R_P$	0.000999986	2.02E-09	normal / B	6.67E-01	1.35E-09	9.00E+99
$r$	1	1.74E-07	normal / A	6.67E-04	1.16E-10	809
$c$	1	3.12E-06	normal / A	6.67E-04	2.08E-09	6
$N$	8	0				
$R_-$	6.6667357E-04					
<b>Total Type A uncertainty</b>					2.1E-09	
<b>Total Type B uncertainty</b>					1.9E-09	
<b>Combined standard uncertainty</b>					2.8E-09	
<b>Effective degrees of freedom</b>					20	
<b>Value of coverage factor k</b>					2.13	
<b>Expanded uncertainty (95 % coverage factor)</b>					6.0E-09	

Table 6: Uncertainty budget for the mean  $R_M$  of +300 A and -300 A nominal primary currents.

Quantity	Estimate	Standard uncertainty	Probability distribution / method of evaluation (A, B)	Sensitivity coefficient	Uncertainty contribution	Degree of freedom
$X_i$	$x_i$	$u(x_i)$		$c_i$	$u(R_j)$	$\nu_i$
$U_s$	0.200043	2.96E-07	normal / B	3.33E-03	9.87E-10	9.00E+99
$U_{s-off}$	0.000000	4.49E-12	normal / B	-3.33E-03	-1.50E-14	9.00E+99
$U_p$	0.0375128	3.90E-08	normal / B	-1.78E-02	-6.92E-10	9.00E+99
$U_{p-off}$	0.0000000	9.96E-14	normal / B	1.78E-02	1.77E-15	9.00E+99
$R_s$	0.999864168	7.00E-07	normal / B	-6.67E-04	-4.67E-10	9.00E+99
$R_p$	0.000999986	2.02E-09	normal / B	6.67E-01	1.35E-09	9.00E+99
$r$	1	1.74E-07	normal / A	6.67E-04	1.16E-10	809
$c$	1	1.44E-06	normal / A	6.67E-04	9.60E-10	6
$N$	8	0				
$R_M$	6.6666536E-04					
<b>Total Type A uncertainty</b>					9.7E-10	
<b>Total Type B uncertainty</b>					1.9E-09	
<b>Combined standard uncertainty</b>					2.1E-09	
<b>Effective degrees of freedom</b>					139	
<b>Value of coverage factor k</b>					2	
<b>Expanded uncertainty (95 % coverage factor)</b>					4.2E-09	

Table 7: Uncertainty budget for +600 A nominal primary current  $R_+$ .

Quantity	Estimate	Standard uncertainty	Probability distribution / method of evaluation (A, B)	Sensitivity coefficient	Uncertainty contribution	Degree of freedom
$X_i$	$x_i$	$u(x_i)$		$c_i$	$u(R_j)$	$\nu_i$
$U_s$	0.400040	5.92E-07	normal / B	1.67E-03	9.87E-10	9.00E+99
$U_{s-off}$	0.000006	9.26E-12	normal / B	-1.67E-03	-1.54E-14	9.00E+99
$U_p$	0.0750171	7.79E-08	normal / B	-8.89E-03	-6.92E-10	9.00E+99
$U_{p-off}$	0.0000015	1.60E-12	normal / B	8.89E-03	1.42E-14	9.00E+99
$R_s$	0.999864168	7.00E-07	normal / B	-6.67E-04	-4.67E-10	9.00E+99
$R_p$	0.000999981	2.02E-09	normal / B	6.67E-01	1.35E-09	9.00E+99
$r$	1	1.63E-07	normal / A	6.67E-04	1.09E-10	593
$c$	1	9.76E-07	normal / A	6.67E-04	6.51E-10	5
$N$	8	0				
$R_+$	6.6666306E-04					
<b>Total Type A uncertainty</b>					6.6E-10	
<b>Total Type B uncertainty</b>					1.9E-09	
<b>Combined standard uncertainty</b>					2.0E-09	
<b>Effective degrees of freedom</b>					430	
<b>Value of coverage factor k</b>					2	
<b>Expanded uncertainty (95 % coverage factor)</b>					4.0E-09	

Table 8: Uncertainty budget for -600 A nominal primary current  $R_-$ .

Quantity	Estimate	Standard uncertainty	Probability distribution / method of evaluation (A, B)	Sensitivity coefficient	Uncertainty contribution	Degree of freedom
$X_i$	$x_i$	$u(x_i)$		$c_i$	$u(R_j)$	$\nu_i$
$U_s$	-0.400029	5.92E-07	normal / B	-1.67E-03	-9.87E-10	9.00E+99
$U_{s-off}$	0.000006	9.26E-12	normal / B	1.67E-03	1.54E-14	9.00E+99
$U_p$	-0.0750145	7.79E-08	normal / B	8.89E-03	6.92E-10	9.00E+99
$U_{p-off}$	0.0000015	1.60E-12	normal / B	-8.89E-03	-1.42E-14	9.00E+99
$R_s$	0.999864168	7.00E-07	normal / B	-6.67E-04	-4.67E-10	9.00E+99
$R_p$	0.000999981	2.02E-09	normal / B	6.67E-01	1.35E-09	9.00E+99
$r$	1	1.63E-07	normal / A	6.67E-04	1.09E-10	593
$c$	1	1.71E-06	normal / A	6.67E-04	1.14E-09	5
$N$	8	0				
$R_-$	6.6666088E-04					
<b>Total Type A uncertainty</b>					1.1E-09	
<b>Total Type B uncertainty</b>					1.9E-09	
<b>Combined standard uncertainty</b>					2.2E-09	
<b>Effective degrees of freedom</b>					68	
<b>Value of coverage factor k</b>					2	
<b>Expanded uncertainty (95 % coverage factor)</b>					4.4E-09	

Table 9: Uncertainty budget for the mean  $R_M$  of +600 A and -600 A nominal primary currents.

Quantity	Estimate	Standard uncertainty	Probability distribution / method of evaluation (A, B)	Sensitivity coefficient	Uncertainty contribution	Degree of freedom
$X_i$	$x_i$	$u(x_i)$		$c_i$	$u(R_i)$	$\nu_i$
$U_s$	0.400035	5.92E-07	normal / B	1.67E-03	9.87E-10	9.00E+99
$U_{s-off}$	0.000000	9.26E-12	normal / B	-1.67E-03	-1.54E-14	9.00E+99
$U_p$	0.0750158	7.79E-08	normal / B	-8.89E-03	-6.92E-10	9.00E+99
$U_{p-off}$	0.0000000	1.60E-12	normal / B	8.89E-03	1.42E-14	9.00E+99
$R_s$	0.999864168	7.00E-07	normal / B	-6.67E-04	-4.67E-10	9.00E+99
$R_p$	0.000999981	2.02E-09	normal / B	6.67E-01	1.35E-09	9.00E+99
$r$	1	1.63E-07	normal / A	6.67E-04	1.09E-10	593
$c$	1	1.28E-06	normal / A	6.67E-04	8.55E-10	5
$N$	8	0				
$R_M$	6.6666197E-04					
			<b>Total Type A uncertainty</b>		8.6E-10	
			<b>Total Type B uncertainty</b>		1.9E-09	
			<b>Combined standard uncertainty</b>		2.1E-09	
			<b>Effective degrees of freedom</b>		168	
			<b>Value of coverage factor k</b>		2	
			<b>Expanded uncertainty (95 % coverage factor)</b>		4.1E-09	

## 8. PTB – Physikalisch-Technische Bundesanstalt (Germany)

### 8.1 Detailed uncertainty budget

#### Model Equation:

$$I_{sp} = (U_{sp} - U_0 + U_{spec}) / R_s;$$

$$I_{pp} = (U_{pp} - U_0 + U_{spec}) / R_p * V_{9923};$$

$$I_{s0} = ((U_{s0} - U_0) - (U_{p0} - U_0)) / (R_p / V_{9923} * V_{LEM} / R_s) / R_s;$$

$$R_p = (I_{sp} - I_{s0}) / I_{pp};$$

$$I_{sm} = (U_{sm} - U_0 + U_{spec}) / R_s;$$

$$I_{pm} = (U_{pm} - U_0 + U_{spec}) / R_p * V_{9923};$$

$$R_m = (I_{sm} - I_{s0}) / I_{pm};$$

$$R = (R_p + R_m) / 2$$

#### List of Quantities:

Quantity	Unit	Definition
$I_{sp}$	A	positive secondary current
$U_{sp}$	V	positive voltage at Rs
$U_0$	V	offset voltage DMM
$U_{spec}$	V	10 minute transfer specification DMM
$R_s$	$\Omega$	resistor at LEM (1,9 $\Omega$ )
$I_{pp}$	A	positive primary current
$U_{pp}$	V	positive voltage at Rp
$R_p$	$\Omega$	resistance at reference transformer
$V_{9923}$		nominal ratio of the reference transformer
$I_{s0}$	A	LEM offset current
$U_{s0}$	V	offset voltage of LEM with current source zero/operate
$U_{p0}$	V	offset voltage of reference transformer with current source zero/operate
$V_{LEM}$		nominal ratio of LEM
$R_p$		positive ratio LEM
$I_{sm}$	A	negative secondary current
$U_{sm}$	V	negative voltage at Rs
$I_{pm}$	A	negative primary current
$U_{pm}$	V	negative voltage at Rp
$R_m$		negative ratio LEM
$R$		final result, ratio of LEM

#### Uncertainty Budgets:

##### $I_{sp}$ : positive secondary current

Quantity	Value	Standard Uncertainty	Degrees of Freedom	Distribution	Sensitivity Coefficient	Uncertainty Contribution	Index
$U_{sp}$	0.1140010000 V	$14.9 \cdot 10^{-9}$ V	9	normal	0.53	$7.8 \cdot 10^{-9}$ A	0.5 %
$U_0$	$600 \cdot 10^{-9}$ V	$173 \cdot 10^{-9}$ V	$\infty$	rectangular	-0.53	$-91 \cdot 10^{-9}$ A	64.2 %
$U_{spec}$	0.0 V	$115 \cdot 10^{-9}$ V	100	normal	0.53	$61 \cdot 10^{-9}$ A	28.3 %
$R_s$	1.900036000 $\Omega$	$950 \cdot 10^{-9}$ $\Omega$	100	normal	-0.032	$-30 \cdot 10^{-9}$ A	7.0 %
$I_{sp}$	0.059999074 A	$114 \cdot 10^{-9}$ A	1200				

**I<sub>pp</sub>: positive primary current**

Quantity	Value	Standard Uncertainty	Degrees of Freedom	Distribution	Sensitivity Coefficient	Uncertainty Contribution	Index
$U_0$	$600 \cdot 10^{-9}$ V	$173 \cdot 10^{-9}$ V	$\infty$	rectangular	-100	$-17 \cdot 10^{-6}$ A	5.8 %
$U_{spec}$	0.0 V	$115 \cdot 10^{-9}$ V	100	normal	100	$11 \cdot 10^{-6}$ A	2.5 %
$U_{pp}$	0.9000381700 V	$71.6 \cdot 10^{-9}$ V	9	normal	100	$7.2 \cdot 10^{-6}$ A	1.0 %
$R_p$	10.00018000 $\Omega$	$5.00 \cdot 10^{-6}$ $\Omega$	100	normal	-9.0	$-45 \cdot 10^{-6}$ A	38.9 %
$V_{9923}$	1000.000000	$577 \cdot 10^{-6}$	$\infty$	rectangular	0.090	$52 \cdot 10^{-6}$ A	51.8 %
$I_{pp}$	90.0021370 A	$72.2 \cdot 10^{-6}$ A	660				

**I<sub>s0</sub>: LEM offset current**

Quantity	Value	Standard Uncertainty	Degrees of Freedom	Distribution	Sensitivity Coefficient	Uncertainty Contribution	Index
$U_0$	$600 \cdot 10^{-9}$ V	$173 \cdot 10^{-9}$ V	$\infty$	rectangular	-0.46	$-80 \cdot 10^{-9}$ A	59.2 %
$R_s$	1.900036000 $\Omega$	$950 \cdot 10^{-9}$ $\Omega$	100	normal	$1.0 \cdot 10^{-6}$	$960 \cdot 10^{-15}$ A	0.0 %
$R_p$	10.00018000 $\Omega$	$5.00 \cdot 10^{-6}$ $\Omega$	100	normal	$42 \cdot 10^{-9}$	$210 \cdot 10^{-15}$ A	0.0 %
$V_{9923}$	1000.000000	$577 \cdot 10^{-6}$	$\infty$	rectangular	$-420 \cdot 10^{-12}$	$-240 \cdot 10^{-15}$ A	0.0 %
$U_{s0}$	$-3.0333 \cdot 10^{-6}$ V	$97.7 \cdot 10^{-9}$ V	2	normal	0.53	$51 \cdot 10^{-9}$ A	24.7 %
$U_{p0}$	$6.873 \cdot 10^{-6}$ V	$622 \cdot 10^{-9}$ V	2	normal	-0.067	$-41 \cdot 10^{-9}$ A	16.1 %
$V_{LEM}$	1500.0						
$I_{s0}$	$-2.330 \cdot 10^{-6}$ A	$103 \cdot 10^{-9}$ A	23				

**R<sub>p</sub>: positive ratio LEM**

Quantity	Value	Standard Uncertainty	Degrees of Freedom	Distribution	Sensitivity Coefficient	Uncertainty Contribution	Index
$U_{sp}$	0.1140010000 V	$14.9 \cdot 10^{-9}$ V	9	normal	$5.8 \cdot 10^{-3}$	$87 \cdot 10^{-12}$	0.6 %
$U_0$	$600 \cdot 10^{-9}$ V	$173 \cdot 10^{-9}$ V	$\infty$	rectangular	$-250 \cdot 10^{-12}$	$-44 \cdot 10^{-18}$	0.0 %
$U_{spec}$	0.0 V	$115 \cdot 10^{-9}$ V	100	normal	$5.1 \cdot 10^{-3}$	$590 \cdot 10^{-12}$	27.3 %
$R_s$	1.900036000 $\Omega$	$950 \cdot 10^{-9}$ $\Omega$	100	normal	$-350 \cdot 10^{-6}$	$-330 \cdot 10^{-12}$	8.8 %
$U_{pp}$	0.9000381700 V	$71.6 \cdot 10^{-9}$ V	9	normal	$-740 \cdot 10^{-6}$	$-53 \cdot 10^{-12}$	0.2 %
$R_p$	10.00018000 $\Omega$	$5.00 \cdot 10^{-6}$ $\Omega$	100	normal	$67 \cdot 10^{-6}$	$330 \cdot 10^{-12}$	8.8 %
$V_{9923}$	1000.000000	$577 \cdot 10^{-6}$	$\infty$	rectangular	$-670 \cdot 10^{-9}$	$-380 \cdot 10^{-12}$	11.7 %
$U_{s0}$	$-3.0333 \cdot 10^{-6}$ V	$97.7 \cdot 10^{-9}$ V	2	normal	$-5.8 \cdot 10^{-3}$	$-570 \cdot 10^{-12}$	25.8 %
$U_{p0}$	$6.873 \cdot 10^{-6}$ V	$622 \cdot 10^{-9}$ V	2	normal	$740 \cdot 10^{-6}$	$460 \cdot 10^{-12}$	16.8 %

Quantity	Value	Standard Uncertainty	Degrees of Freedom	Distribution	Sensitivity Coefficient	Uncertainty Contribution	Index
							%
$V_{LEM}$	1500.0						
$R_p$	$666.66644 \cdot 10^{-6}$	$1.12 \cdot 10^{-9}$	20				

**I<sub>sm</sub>: negative secondary current**

Quantity	Value	Standard Uncertainty	Degrees of Freedom	Distribution	Sensitivity Coefficient	Uncertainty Contribution	Index
$U_0$	$600 \cdot 10^{-9}$ V	$173 \cdot 10^{-9}$ V	$\infty$	rectangular	-0.53	$-91 \cdot 10^{-9}$ A	64.4 %
$U_{spec}$	0.0 V	$115 \cdot 10^{-9}$ V	100	normal	0.53	$61 \cdot 10^{-9}$ A	28.4 %
$R_s$	1.900036000 $\Omega$	$950 \cdot 10^{-9}$ $\Omega$	100	normal	0.032	$30 \cdot 10^{-9}$ A	7.0 %
$U_{sm}$	-0.1140096900 V	$10.0 \cdot 10^{-9}$ V	9	normal	0.53	$5.3 \cdot 10^{-9}$ A	0.2 %
$I_{sm}$	-0.060004279 A	$114 \cdot 10^{-9}$ A	1200				

**I<sub>pm</sub>: negative primary current**

Quantity	Value	Standard Uncertainty	Degrees of Freedom	Distribution	Sensitivity Coefficient	Uncertainty Contribution	Index
$U_0$	$600 \cdot 10^{-9}$ V	$173 \cdot 10^{-9}$ V	$\infty$	rectangular	-100	$-17 \cdot 10^{-6}$ A	5.7 %
$U_{spec}$	0.0 V	$115 \cdot 10^{-9}$ V	100	normal	100	$11 \cdot 10^{-6}$ A	2.5 %
$R_p$	10.00018000 $\Omega$	$5.00 \cdot 10^{-6}$ $\Omega$	100	normal	9.0	$45 \cdot 10^{-6}$ A	38.6 %
$V_{9923}$	1000.000000	$577 \cdot 10^{-6}$	$\infty$	rectangular	-0.090	$-52 \cdot 10^{-6}$ A	51.5 %
$U_{pm}$	-0.9000427800 V	$91.7 \cdot 10^{-9}$ V	9	normal	100	$9.2 \cdot 10^{-6}$ A	1.6 %
$I_{pm}$	-90.0027180 A	$72.4 \cdot 10^{-6}$ A	660				

**R<sub>m</sub>: negative ratio LEM**

Quantity	Value	Standard Uncertainty	Degrees of Freedom	Distribution	Sensitivity Coefficient	Uncertainty Contribution	Index
$U_0$	$600 \cdot 10^{-9}$ V	$173 \cdot 10^{-9}$ V	$\infty$	rectangular	$-1.7 \cdot 10^{-9}$	$-290 \cdot 10^{-18}$	0.0 %
$U_{spec}$	0.0 V	$115 \cdot 10^{-9}$ V	100	normal	$-5.1 \cdot 10^{-3}$	$-590 \cdot 10^{-12}$	27.3 %
$R_s$	1.900036000 $\Omega$	$950 \cdot 10^{-9}$ $\Omega$	100	normal	$-350 \cdot 10^{-6}$	$-330 \cdot 10^{-12}$	8.8 %
$R_p$	10.00018000 $\Omega$	$5.00 \cdot 10^{-6}$ $\Omega$	100	normal	$67 \cdot 10^{-6}$	$330 \cdot 10^{-12}$	8.8 %
$V_{9923}$	1000.000000	$577 \cdot 10^{-6}$	$\infty$	rectangular	$-670 \cdot 10^{-9}$	$-380 \cdot 10^{-12}$	11.7 %
$U_{s0}$	$-3.0333 \cdot 10^{-6}$ V	$97.7 \cdot 10^{-9}$ V	2	normal	$5.8 \cdot 10^{-3}$	$570 \cdot 10^{-12}$	25.9 %

Quantity	Value	Standard Uncertainty	Degrees of Freedom	Distribution	Sensitivity Coefficient	Uncertainty Contribution	Index
							%
$U_{p0}$	$6.873 \cdot 10^{-6}$ V	$622 \cdot 10^{-9}$ V	2	normal	$-740 \cdot 10^{-6}$	$-460 \cdot 10^{-12}$	16.8 %
$V_{LEM}$	1500.0						
$U_{sm}$	-0.1140096900 V	$10.0 \cdot 10^{-9}$ V	9	normal	$-5.8 \cdot 10^{-3}$	$-58 \cdot 10^{-12}$	0.3 %
$U_{pm}$	-0.9000427800 V	$91.7 \cdot 10^{-9}$ V	9	normal	$740 \cdot 10^{-6}$	$68 \cdot 10^{-12}$	0.4 %
$R_m$	$666.66818 \cdot 10^{-6}$	$1.12 \cdot 10^{-9}$	20				

**R: final result, ratio of LEM**

Quantity	Value	Standard Uncertainty	Degrees of Freedom	Distribution	Sensitivity Coefficient	Uncertainty Contribution	Index
$U_{sp}$	0.1140010000 V	$14.9 \cdot 10^{-9}$ V	9	normal	$2.9 \cdot 10^{-3}$	$44 \cdot 10^{-12}$	0.5 %
$U_0$	$600 \cdot 10^{-9}$ V	$173 \cdot 10^{-9}$ V	$\infty$	rectangular	$-970 \cdot 10^{-12}$	$-170 \cdot 10^{-18}$	0.0 %
$U_{spec}$	0.0 V	$115 \cdot 10^{-9}$ V	100	normal	$17 \cdot 10^{-9}$	$2.0 \cdot 10^{-15}$	0.0 %
$R_s$	1.900036000 $\Omega$	$950 \cdot 10^{-9}$ $\Omega$	100	normal	$-350 \cdot 10^{-6}$	$-330 \cdot 10^{-12}$	29.6 %
$U_{pp}$	0.9000381700 V	$71.6 \cdot 10^{-9}$ V	9	normal	$-370 \cdot 10^{-6}$	$-27 \cdot 10^{-12}$	0.2 %
$R_p$	10.00018000 $\Omega$	$5.00 \cdot 10^{-6}$ $\Omega$	100	normal	$67 \cdot 10^{-6}$	$330 \cdot 10^{-12}$	29.6 %
$V_{9923}$	1000.000000	$577 \cdot 10^{-6}$	$\infty$	rectangular	$-670 \cdot 10^{-9}$	$-380 \cdot 10^{-12}$	39.5 %
$U_{s0}$	$-3.0333 \cdot 10^{-6}$ V	$97.7 \cdot 10^{-9}$ V	2	normal	$-19 \cdot 10^{-9}$	$-1.8 \cdot 10^{-15}$	0.0 %
$U_{p0}$	$6.873 \cdot 10^{-6}$ V	$622 \cdot 10^{-9}$ V	2	normal	$2.4 \cdot 10^{-9}$	$1.5 \cdot 10^{-15}$	0.0 %
$V_{LEM}$	1500.0						
$U_{sm}$	-0.1140096900 V	$10.0 \cdot 10^{-9}$ V	9	normal	$-2.9 \cdot 10^{-3}$	$-29 \cdot 10^{-12}$	0.2 %
$U_{pm}$	-0.9000427800 V	$91.7 \cdot 10^{-9}$ V	9	normal	$370 \cdot 10^{-6}$	$34 \cdot 10^{-12}$	0.3 %
$R$	$666.667311 \cdot 10^{-6}$	$612 \cdot 10^{-12}$	570				

**Results:**

Quantity	Value	Expanded Uncertainty	Coverage factor	Coverage
$I_{sp}$	0.05999907 A	$3.8 \cdot 10^{-6}$ (relativ)	2.00	95% (normal)
$I_{pp}$	90.00214 A	$1.6 \cdot 10^{-6}$ (relativ)	2.00	95% (normal)
$I_{s0}$	$-2.33 \cdot 10^{-6}$ A	$210 \cdot 10^{-9}$ A	2.00	95% (normal)
$R_p$	$666.6664 \cdot 10^{-6}$	$3.4 \cdot 10^{-6}$ (relativ)	2.00	95% (normal)
$I_{sm}$	-0.06000428 A	$3.8 \cdot 10^{-6}$ (relativ)	2.00	95% (normal)
$I_{pm}$	-90.00272 A	$1.6 \cdot 10^{-6}$ (relativ)	2.00	95% (normal)
$R_m$	$666.6682 \cdot 10^{-6}$	$3.4 \cdot 10^{-6}$ (relativ)	2.00	95% (normal)
$R$	$666.6673 \cdot 10^{-6}$	$1.8 \cdot 10^{-6}$ (relativ)	2.00	95% (normal)

## 9. SIQ – Slovenian Institute of Quality and Metrology (Slovenia)

### 9.1 Uncertainty budgets

#### Uncertainty budget for 50 A measuring head calibration

Current sensitivity of 50 A measuring head  $M_{50}$  was calculated using the following equation:

$$\text{Eq. 3-1: } M_{50} = \frac{N_{50} \cdot (U_1 + K_{\text{spec}_1} + K_{r_1})}{(R_s + K_d + K_{t_c}) \cdot (U_2 + K_{\text{spec}_2} + K_{r_2})}$$

where

$N_{50}$	number of windings of the auxiliary winding on 50 A measuring head,
$U_1$	voltage measured on standard resistor,
$U_2$	voltage measured at the output of the zero flux system for 50 A measuring head,
$R_s$	resistance of standard resistor,
$K_{\text{spec}_1}$	correction due to the DMM <sub>1</sub> accuracy,
$K_{r_1}$	correction due to the DMM <sub>1</sub> resolution,
$K_d$	correction due to the drift of the standard resistor,
$K_{t_c}$	correction due to the temperature dependence of the standard resistor,
$K_{\text{spec}_2}$	correction due to the DMM <sub>2</sub> accuracy,
$K_{r_2}$	correction due to the DMM <sub>2</sub> resolution.

#### Contributions to standard uncertainty

##### Voltage measured on standard resistor and at the output of the zero flux system ( $U_1, U_2$ )

This value is a mean of usually five measurements measured with digital voltmeter. Standard uncertainty contribution of this value is a type A uncertainty, which is calculated as a standard deviation of the mean of all measurements.

##### Correction due to the DMM<sub>1</sub> and DMM<sub>2</sub> resolution ( $K_{r_1}, K_{r_2}$ )

The quantity corresponding to the least significant digit if the digital multimeter display equals the finite resolution of the display. The correction is estimated to be 0 V with associated uncertainty  $\pm$  half the resolution (half the magnitude of the least significant digit) with rectangular distribution.

$$u_r = \frac{\text{DMM}_{\text{resolution}}}{2 \cdot \sqrt{3}} \quad \text{- rectangular probability distribution.}$$

##### Correction due to the DMM<sub>1</sub> and DMM<sub>2</sub> accuracy ( $K_{\text{spec}_1}, K_{\text{spec}_2}$ )

This value is estimated to be 0 V with associated standard uncertainty, which is taken from DMM manufacturer's specifications. This uncertainty is assumed to have rectangular probability distribution.

##### Resistance of standard resistor ( $R_s$ )

This value is taken from standard resistors last calibration certificate together with its associated uncertainty which is given with coverage factor  $k = 2$ . This uncertainty contribution has normal probability distribution.

##### Correction due to the drift of the standard resistor ( $K_d$ )

This value is taken to be 0  $\Omega$  with associated uncertainty estimated from previous calibration certificates for the given resistor. Drift is estimated in  $\Omega/\text{year}$  and this value is then taken as uncertainty of the drift. This value has rectangular probability distribution.

##### Correction due to the temperature dependence of the standard resistor ( $K_{t_c}$ )

This value is taken to be 0  $\Omega$  with associated uncertainty calculated from temperature coefficient of the standard resistor and with the temperature difference of the environmental conditions in which the measurements are made and the temperature at which standard resistor was calibrated. This temperature difference is usually taken to be the uncertainty in temperature measurement if measurements are made at the same conditions as the resistor was calibrated at (laboratory conditions). This uncertainty contribution is assumed to have rectangular probability distribution.



**Correction due to the resolution of DMM ( $K_{rp}, K_{rs}, K_{ro}$ )**

The quantity corresponding to the least significant digit if the digital multimeter display equals the finite resolution of the display. The correction is estimated to be 0 V with associated uncertainty  $\pm$  half the resolution (half the magnitude of the least significant digit) with rectangular distribution.

$$u_r = \frac{DMM\_resolution}{2 \cdot \sqrt{3}} \quad \text{- rectangular probability distribution.}$$

**Correction due to the specification of DMM ( $K_{ddmp}, K_{dmms}, K_{dmno}$ )**

Digital multimeter is operated within the specified working temperature range ( $23 \text{ }^\circ\text{C} \pm 2 \text{ }^\circ\text{C}$ ) and is recalibrated at intervals recommended by the manufacturer with compliant with specification status, meaning that for all measured points compliance with specified limit of error minus uncertainty of measurement was confirmed. Rectangular probability distribution is taken into account for this uncertainty contribution.

**Correction due to the zero flux system linearity ( $K_{lin}$ )**

This value is taken to be 0 V with associated uncertainty which is 10 ppm of the measured output voltage from zero flux system. This value is given by the manufacturer of the zero flux system. When zero flux system was put into use this value was checked and confirmed. Linearity check of the zero flux system is to be performed in agreed intervals. Rectangular probability distribution is taken into account for this uncertainty contribution.

**Current sensitivity of zero flux measuring head ( $M$ )**

This value is taken from calibration of the measuring head used together with its associated uncertainty which is given with coverage factor  $k = 2$ . Normal probability distribution is taken into account for this uncertainty contribution.

**Number of windings through the current transducer under calibration ( $N$ )**

This is an integer value of windings through the current transducer under calibration. It is exact value of (6) and it has no associated uncertainty.

**Resistance of standard resistor ( $R_s$ )**

This value is taken from standard resistors last calibration certificate together with its associated uncertainty which is given with coverage factor  $k = 2$ . This uncertainty contribution has normal probability distribution.

**Correction of the resistance of standard resistor due to drift since last calibration ( $K_d$ )**

The drift of the resistance of the standard resistor since its last calibration is estimated from its calibration history. Rectangular probability contribution is associated for this type of uncertainty.

**Correction due to the temperature dependence of the standard resistor ( $K_{tc}$ )**

This value is taken to be 0  $\Omega$  with associated uncertainty calculated from temperature coefficient of the standard resistor and with the temperature difference of the environmental conditions in which the measurements are made and the temperature at which standard resistor was calibrated. This temperature difference is usually taken to be the uncertainty in temperature measurement if measurements are made at the same conditions as the resistor was calibrated at (laboratory conditions). This uncertainty contribution is assumed to have rectangular probability distribution.

## 9.2 Measurement uncertainty calculation

Uncertainty of ratio  $unc(R)$  was calculated as combination of uncertainty of primary  $unc(U_p)$  and uncertainty of secondary current  $unc(U_s)$  as

$$\text{En. 3-7:} \quad unc(R) = \sqrt{unc(U_s)^2 + unc(U_p)^2}.$$

### Current 90 A

Calculation of measurement uncertainty of primary and secondary current was done according to equation Eq. 3.4 and Eq. 3.5.

**Mathematical model of measurement:**

Quantity $X_i$	Estimate $x_i$	Standard uncertainty $u(x_i)$	Probability distribution	Div.	Sensitivity coefficient $c_i$	Uncertainty contribution $u_i(y)$	Effective degr. of freedom $\nu_i$
$U_p$	3,000265 V	0,000009 V	normal	1	29,9992 A/V	0,000283 A	9
$K_{rp}$	0 V	0,000003 V	rectangular	1,73	29,9992 A/V	0,000087 A	1E+99
$K_{dmmp}$	0 V	0,000007 V	rectangular	1,73	29,9992 A/V	0,000217 A	1E+99
$K_{lin}$	0 V	0,000017 V	rectangular	1,73	29,9992 A/V	0,000520 A	1E+99
$M$	4,999859 A/V	0,00002 A/V	normal	2	18,002 V	0,000378 A	1E+99
$N$	6	-	-	-	-	-	-
$I_p$	90,0054 A	Calculated uncertainty:				0,0007 A	420
		Expanded uncertainty of measurement:				0,0015 A	
		Relative expanded uncertainty of measurement:				16,4 $\mu$ A/A	

Table 2: Uncertainty budget for measurement of primary current

**Mathematical model of measurement:**

Quantity $X_i$	Estimate $x_i$	Standard uncertainty $u(x_i)$	Probability distribution	Div.	Sensitivity coefficient $c_i$	Uncertainty contribution $u_i(y)$	Effective degr. of freedom $\nu_i$
$U_s$	59,99931 mV	0,000047 mV	normal	1	0,99997 A/V	0,000047 mA	9
$K_{rs}$	0 mV	0,000003 mV	rectangular	1,73	0,99997 A/V	0,000003 mA	1E+99
$K_{dmms}$	0 mV	0,000346 mV	rectangular	1,73	0,99997 A/V	0,000346 mA	1E+99
$U_{off}$	-0,005750 mV	0,000035 mV	normal	1	-0,99997 A/V	-0,000035 mA	9
$K_{ro}$	0 mV	0,000003 mV	rectangular	1,73	-0,99997 A/V	-0,000003 mA	1E+99
$K_{dmms}$	0 mV	0,000173 mV	rectangular	1,73	-0,99997 A/V	-0,000173 mA	1E+99
$R_s$	1,0000301 $\Omega$	0,000001 $\Omega$	normal	2	-60,0014 mA/ $\Omega$	-0,000030 mA	1E+99
$K_d$	0 $\Omega$	0,000001 $\Omega$	rectangular	1,73	-60,0014 mA/ $\Omega$	-0,000035 mA	1E+99
$K_{tc}$	0 $\Omega$	0,000001 $\Omega$	rectangular	1,73	-60,0014 mA/ $\Omega$	-0,000035 mA	1E+99
$I_s$	60,0033 mA	Calculated uncertainty:				0,00039 mA	33875
		Expanded uncertainty of measurement:				0,00079 mA	
		Relative expanded uncertainty of measurement:				13,1 $\mu$ A/A	

Table 3: Uncertainty budget for measurement of secondary current

**Current -90 A**

Calculation of measurement uncertainty of primary and secondary current was done according to equation Eq. 3.4 and Eq. 3.5.

**Mathematical model of measurement:**

Quantity $X_i$	Estimate $x_i$	Standard uncertainty $u(x_i)$	Probability distribution	Div.	Sensitivity coefficient $c_i$	Uncertainty contribution $u_i(y)$	Effective degr. of freedom $\nu_i$
$U_p$	-3,000285 V	0,000006 V	normal	1	29,9992 A/V	0,000184 A	9
$K_{rp}$	0 V	0,000003 V	rectangular	1,73	29,9992 A/V	0,000087 A	1E+99
$K_{dmmp}$	0 V	-0,000007 V	rectangular	1,73	29,9992 A/V	-0,000199 A	1E+99
$K_{lin}$	0 V	-0,000017 V	rectangular	1,73	29,9992 A/V	-0,000520 A	1E+99
$M$	4,999859 A/V	0,00002 A/V	normal	2	-18,002 V	-0,000378 A	1E+99
$N$	6	-	-	-	-	-	-
$I_p$	-90,0060 A	Calculated uncertainty:				0,0007 A	1914
		Expanded uncertainty of measurement:				0,0014 A	
		Relative expanded uncertainty of measurement:				15,6 $\mu$ A/A	

Table 4: Uncertainty budget for measurement of primary current

**Mathematical model of measurement:**

Quantity $X_i$	Estimate $x_i$	Standard uncertainty $u(x_i)$	Probability distribution	Div.	Sensitivity coefficient $c_i$	Uncertainty contribution $u_i(y)$	Effective degr. of freedom $\nu_i$
$U_s$	-60,01110 mV	0,000042 mV	normal	1	0,99997 A/V	0,000042 mA	9
$K_{rs}$	0 mV	0,000003 mV	rectangular	1,73	0,99997 A/V	0,000003 mA	1E+99
$K_{dmms}$	0 mV	0,000346 mV	rectangular	1,73	0,99997 A/V	0,000346 mA	1E+99
$U_{off}$	-0,005750 mV	0,000039 mV	normal	1	-0,99997 A/V	-0,000039 mA	9
$K_{ro}$	0 mV	0,000003 mV	rectangular	1,73	-0,99997 A/V	-0,000003 mA	1E+99
$K_{dmmo}$	0 mV	0,000173 mV	rectangular	1,73	-0,99997 A/V	-0,000173 mA	1E+99
$R_s$	1,0000301 $\Omega$	0,000001 $\Omega$	normal	2	60,0017 mA/ $\Omega$	0,000030 mA	1E+99
$K_d$	0 $\Omega$	0,000001 $\Omega$	rectangular	1,73	60,0017 mA/ $\Omega$	0,000035 mA	1E+99
$K_{tc}$	0 $\Omega$	0,000001 $\Omega$	rectangular	1,73	60,0017 mA/ $\Omega$	0,000035 mA	1E+99
$I_s$	-60,0035 mA		Calculated uncertainty:			0,00039 mA	40556
			Expanded uncertainty of measurement:			0,00079 mA	
			Relative expanded uncertainty of measurement:			13,1 $\mu$ A/A	

Table 5: Uncertainty budget for measurement of secondary current

**Current 300 A**

Calculation of measurement uncertainty of primary and secondary current was done according to equation Eq. 3.4 and Eq. 3.5.

**Mathematical model of measurement:**

Quantity $X_i$	Estimate $x_i$	Standard uncertainty $u(x_i)$	Probability distribution	Div.	Sensitivity coefficient $c_i$	Uncertainty contribution $u_i(y)$	Effective degr. of freedom $\nu_i$
$U_p$	10,00014 V	0,000007 V	normal	1	29,9991 A/V	0,000209 A	9
$K_{rp}$	0 V	0,000003 V	rectangular	1,73	29,9991 A/V	0,000087 A	1E+99
$K_{dmmp}$	0 V	0,000023 V	rectangular	1,73	29,9991 A/V	0,000701 A	1E+99
$K_{lin}$	0 V	0,000058 V	rectangular	1,73	29,9991 A/V	0,001732 A	1E+99
$M$	4,999849 A/V	0,00002 A/V	normal	2	60,001 V	0,001260 A	1E+99
$N$	6	-	-	-	-	-	-
$I_p$	299,9951 A		Calculated uncertainty:			0,0023 A	123717
			Expanded uncertainty of measurement:			0,0045 A	
			Relative expanded uncertainty of measurement:			15,1 $\mu$ A/A	

Table 6: Uncertainty budget for measurement of primary current

**Mathematical model of measurement:**

Quantity $X_i$	Estimate $x_i$	Standard uncertainty $u(x_i)$	Probability distribution	Div.	Sensitivity coefficient $c_i$	Uncertainty contribution $u_i(y)$	Effective degr. of freedom $\nu_i$
$U_s$	199,99497 mV	0,000022 mV	normal	1	0,99997 A/V	0,000022 mA	9
$K_{rs}$	0 mV	0,000003 mV	rectangular	1,73	0,99997 A/V	0,000003 mA	1E+99
$K_{dmms}$	0 mV	0,000635 mV	rectangular	1,73	0,99997 A/V	0,000635 mA	1E+99
$U_{off}$	-0,006904 mV	0,000042 mV	normal	1	-0,99997 A/V	-0,000042 mA	9
$K_{ro}$	0 mV	0,000003 mV	rectangular	1,73	-0,99997 A/V	-0,000003 mA	1E+99
$K_{dmmo}$	0 mV	0,000173 mV	rectangular	1,73	-0,99997 A/V	-0,000173 mA	1E+99
$R_s$	1,0000301 $\Omega$	0,000001 $\Omega$	normal	2	-199,9898 mA/ $\Omega$	-0,000100 mA	1E+99
$K_d$	0 $\Omega$	0,000001 $\Omega$	rectangular	1,73	-199,9898 mA/ $\Omega$	-0,000115 mA	1E+99
$K_{tc}$	0 $\Omega$	0,000001 $\Omega$	rectangular	1,73	-199,9898 mA/ $\Omega$	-0,000115 mA	1E+99
$I_s$	199,9959 mA		Calculated uncertainty:			0,00068 mA	551395
			Expanded uncertainty of measurement:			0,00135 mA	
			Relative expanded uncertainty of measurement:			6,8 $\mu$ A/A	

Table 7: Uncertainty budget for measurement of secondary current

**Current -300 A**

Calculation of measurement uncertainty of primary and secondary current was done according to equation Eq. 3.4 and Eq. 3.5.

**Mathematical model of measurement:**

Quantity $X_i$	Estimate $x_i$	Standard uncertainty $u(x_i)$	Probability distribution	Div.	Sensitivity coefficient $c_i$	Uncertainty contribution $u_i(y)$	Effective degr. of freedom $\nu_i$
$U_p$	-10,00020 V	0,000003 V	normal	1	29,9991 A/V	0,000104 A	9
$K_{rp}$	0 V	0,000003 V	rectangular	1,73	29,9991 A/V	0,000087 A	1E+99
$K_{dmmp}$	0 V	-0,000023 V	rectangular	1,73	29,9991 A/V	-0,000684 A	1E+99
$K_{lin}$	0 V	-0,000058 V	rectangular	1,73	29,9991 A/V	-0,001732 A	1E+99
$M$	4,999843 A/V	0,00002 A/V	normal	2	-60,001 V	-0,001260 A	1E+99
$N$	6	-	-	-	-	-	-
$I_p$	-299,9964 A	Calculated uncertainty:				0,0023 A	2011790
		Expanded uncertainty of measurement:				0,0045 A	
		Relative expanded uncertainty of measurement:				15,0 $\mu$ A/A	

Table 8: Uncertainty budget for measurement of primary current

**Mathematical model of measurement:**

Quantity $X_i$	Estimate $x_i$	Standard uncertainty $u(x_i)$	Probability distribution	Div.	Sensitivity coefficient $c_i$	Uncertainty contribution $u_i(y)$	Effective degr. of freedom $\nu_i$
$U_s$	-200,0043 mV	0,000042 mV	normal	1	0,99997 A/V	0,000042 mA	9
$K_{rs}$	0 mV	0,000003 mV	rectangular	1,73	0,99997 A/V	0,000003 mA	1E+99
$K_{dmms}$	0 mV	0,000751 mV	rectangular	1,73	0,99997 A/V	0,000751 mA	1E+99
$U_{off}$	-0,002164 mV	0,000039 mV	normal	1	-0,99997 A/V	-0,000039 mA	9
$K_{ro}$	0 mV	0,000003 mV	rectangular	1,73	-0,99997 A/V	-0,000003 mA	1E+99
$K_{dmms}$	0 mV	0,000173 mV	rectangular	1,73	-0,99997 A/V	-0,000173 mA	1E+99
$R_s$	1,0000301 $\Omega$	0,000001 $\Omega$	normal	2	199,990 mA/ $\Omega$	0,000100 mA	1E+99
$K_d$	0 $\Omega$	0,000001 $\Omega$	rectangular	1,73	199,990 mA/ $\Omega$	0,000115 mA	1E+99
$K_{tc}$	0 $\Omega$	0,000001 $\Omega$	rectangular	1,73	199,990 mA/ $\Omega$	0,000115 mA	1E+99
$I_s$	-199,9961 mA	Calculated uncertainty:				0,00079 mA	645400
		Expanded uncertainty of measurement:				0,00157 mA	
		Relative expanded uncertainty of measurement:				7,9 $\mu$ A/A	

Table 9: Uncertainty budget for measurement of secondary current

## 10. SP – SP Technical Research Institute of Sweden (Sweden)

### 10.1 Detailed uncertainty budget

The value of the unknown current ratio,  $R$ , is obtained from the relationship:

$$R = R_s \cdot \frac{1}{R_m} \cdot \frac{1}{N} \cdot r \cdot (1 + \delta r) \cdot (1 + \delta_{rep})$$

where:

- $R$  - the value of the unknown current ratio ( $I_S/I_P$ )
- $R_s$  - the value of the reference resistance
- $R_m$  - the value of the load resistance
- $N$  - the number of turns of the primary current conductor through the primary through hole
- $r$  - the indicated resistance ratio of the current comparator bridge
- $\delta r$  - correction for the error in the resistance ratio due to calibration and stability
- $\delta_{rep}$  - correction for the error due to reproducibility (centering error and placement of the primary current conductor etc...)

Based on the model equation the relative standard uncertainty of the measured current ratio,  $u(R)/R$ , can be determined as:

$$\left(\frac{u(R)}{R}\right)^2 = \left(\frac{u(R_s)}{R_s}\right)^2 + \left(\frac{u(R_m)}{R_m}\right)^2 + \left(\frac{u(r)}{r}\right)^2 + u^2(\delta r) + u^2(\delta_{rep})$$

where:

- $u(R_s)$  - uncertainty in the value of the reference resistance due to calibration, stability, temperature and current dependence but excluding the uncertainty of our realization of the resistance unit
- $u(R_m)$  - uncertainty in the value of the load resistance due to calibration, stability, temperature and current dependence but excluding the uncertainty of our realization of the resistance unit
- $u(r)$  - standard deviation of the mean of the measured resistance ratio
- $u(\delta r)$  - uncertainty in the resistance ratio due to calibration and stability
- $u(\delta_{rep})$  - uncertainty due to reproducibility (centering error and placement of the primary current conductor etc...)

Uncertainty budget for 90 A primary current

Quantity $X_i$	Estimate $x_i$	Relative standard uncertainty, ( $10^{-6}$ ) $u(x_i)$	Probability distribution /method of evaluation (A, B)	Sensitivity coefficient $c_i$	Relative uncertainty contribution, ( $10^{-6}$ ) $u(R_i)$	Degree of freedom $\nu_i$
$R_s$	1 $\Omega$ <sup>1)</sup>	0.58	rectangular / B	1	0.58	$\infty$
$R_m$	1 $\Omega$ <sup>2)</sup>	0.58	rectangular / B	1	0.58	$\infty$
$r$	1:500 <sup>3)</sup>	0.13	normal / A	1	0.13	10
$\delta r$	0	0.87	rectangular / B	1	0.87	$\infty$
$\delta_{rep}$	0	1.73	rectangular / B	1	1.73	$\infty$
$R$	1:1500					
Combined relative standard uncertainty ( $10^{-6}$ ):					2.2	
Effective degrees of freedom:					2387	
Expanded relative uncertainty (95% coverage factor) ( $10^{-6}$ ):					4.4	

1) 1  $\Omega$ , 1.6  $\Omega$  or 7.8  $\Omega$  depending on  $N$ ,  $R_m$  and  $r$

2) 0.8  $\Omega$ , 1  $\Omega$  or 1.6  $\Omega$  depending on  $N$ ,  $R_s$  and  $r$

3) depends on the number of turns,  $N$ , and the ratio between  $R_s$  and  $R_m$

## Uncertainty budget for 300 A primary current

Quantity $X_i$	Estimate $x_i$	Relative standard uncertainty, ( $10^{-6}$ ) $u(x_i)$	Probability distribution /method of evaluation (A, B)	Sensitivity coefficient $c_i$	Relative uncertainty contribution, ( $10^{-6}$ ) $u(R_i)$	Degree of freedom $\nu_i$
$R_s$	1.6 $\Omega$	0.58	rectangular / B	1	0.58	$\infty$
$R_m$	1 $\Omega$ <sup>1)</sup>	0.58	rectangular / B	1	0.58	$\infty$
$r$	1:1000 <sup>2)</sup>	0.24	normal / A	1	0.24	3
$\delta r$	0	0.87	rectangular / B	1	0.87	$\infty$
$\delta_{rep}$	0	1.73	rectangular / B	1	1.73	$\infty$
$R$	1:1500					
		Combined relative standard uncertainty ( $10^{-6}$ ):			2.2	
		Effective degrees of freedom:			2158	
		Expanded relative uncertainty (95% coverage factor) ( $10^{-6}$ ):			4.4	

1) 0.8  $\Omega$  or 1  $\Omega$  depending on  $N$ ,  $R_s$  and  $r$

2) depends on the number of turns,  $N$ , and the ratio between  $R_s$  and  $R_m$

## 11. VSL – VSL Dutch Metrology Institute (Netherlands)

### 11.1 Detailed uncertainty budget

#### MATHEMATICAL MODEL

The following model equation is the basis for the uncertainty budget of the DC current ratio calibrations performed in this comparison:

$$r_{DUT} = r_{cc} \cdot (R_s / R_d) \cdot (1 + \delta_{ratio} + \delta_{scaling} + \delta_{pos}); \quad (6)$$

with:

$$R_s = R_{snom} \cdot (1 + \delta_{Rs} + \delta_{Rsstab} + \delta_{RsT}); \quad (7)$$

$$R_d = R_{dnom} \cdot (1 + \delta_{Rd} + \delta_{Rdstab} + \delta_{RdT}); \quad (8)$$

The different quantities are explained in the table below. For the 300 A and 600 A calibrations, where multiple primary current turns are used, the  $(R_s / R_d)$  term in equation 6 is equal to  $(R_s / 3 \cdot R_d)$  and  $(R_s / 6 \cdot R_d)$  respectively.

Quantity	Unit	Definition
$r_{DUT}$		Current ratio of the device under test (DUT) at used primary current
$r_{cc}$		Current ratio of the current comparator in the measurement bridge
$R_s$	$\Omega$	Resistance value of reference resistor
$R_d$	$\Omega$	Resistance value of burden resistor
$\delta_{ratio}$		Ratio deviation measured by the measurement bridge
$\delta_{scaling}$		Error due to scaling using 3 or 6 turns instead of a single turn for applying the primary current
$\delta_{pos}$		Effect of positioning of the current conductors on the DUT current ratio
$R_{snom}$	$\Omega$	Nominal value of the reference resistor
$\delta_{Rs}$		Calibrated $R_s$ deviation from nominal
$\delta_{Rsstab}$		Stability of $R_s$ during current ratio measurement
$\delta_{RsT}$		Effect of temperature on $R_s$
$R_{dnom}$	$\Omega$	Nominal value of the burden resistor
$\delta_{Rd}$		Calibrated $R_d$ deviation from nominal
$\delta_{Rdstab}$		Stability of $R_d$ during current ratio measurement
$\delta_{RdT}$		Effect of temperature on $R_d$

**UNCERTAINTY BUDGET 90 A**

Using the model equation in section 5.1, the following uncertainty budget follows for the 90 A DC primary current calibration:

Quantity	Value	Standard Uncertainty	Distribution	Sensitivity Coefficient	Uncertainty Contribution
$r_{cc}$	$1.000000000 \cdot 10^{-3}$	$120 \cdot 10^{-12}$	normal	0.67	$80 \cdot 10^{-12}$
$R_s$	$1.000004200 \Omega$	$129 \cdot 10^{-9} \Omega$			
$R_d$	$1.500051090 \Omega$	$260 \cdot 10^{-9} \Omega$			
$\delta_{ratio}$	$29.480 \cdot 10^{-6}$	$300 \cdot 10^{-9}$	normal	$670 \cdot 10^{-6}$	$200 \cdot 10^{-12}$
$\delta_{scaling}$	0.0	$1.00 \cdot 10^{-9}$	normal	$670 \cdot 10^{-6}$	$670 \cdot 10^{-15}$
$\delta_{pos}$	0.0	$173 \cdot 10^{-9}$	rectangular	$670 \cdot 10^{-6}$	$120 \cdot 10^{-12}$
$R_{snom}$	$1.0 \Omega$				
$\delta_{Rs}$	$4.200 \cdot 10^{-6}$	$100 \cdot 10^{-9}$	normal	$670 \cdot 10^{-6}$	$67 \cdot 10^{-12}$
$\delta_{Rstab}$	0.0	$57.7 \cdot 10^{-9}$	rectangular	$670 \cdot 10^{-6}$	$38 \cdot 10^{-12}$
$\delta_{RsT}$	0.0	$57.7 \cdot 10^{-9}$	rectangular	$670 \cdot 10^{-6}$	$38 \cdot 10^{-12}$
$R_{dnom}$	$1.5 \Omega$				
$\delta_{Rd}$	$34.060 \cdot 10^{-6}$	$150 \cdot 10^{-9}$	normal	$-670 \cdot 10^{-6}$	$-100 \cdot 10^{-12}$
$\delta_{Rdstab}$	0.0	$86.6 \cdot 10^{-9}$	rectangular	$-670 \cdot 10^{-6}$	$-58 \cdot 10^{-12}$
$\delta_{RdT}$	0.0	$5.77 \cdot 10^{-9}$	rectangular	$-670 \cdot 10^{-6}$	$-3.8 \cdot 10^{-12}$
$r_{DUT}$	$666.666413 \cdot 10^{-6}$	$285 \cdot 10^{-12}$			

With as final result:  $r_{DUT-90A} = 666.66641 \cdot 10^{-6} \pm 0.85 \cdot 10^{-6}$  (relative) ( $k = 2$ )

**UNCERTAINTY BUDGET 300 A**

Using the model equation in section 5.1, the following uncertainty budget follows for the 300 A DC primary current calibration:

Quantity	Value	Standard Uncertainty	Distribution	Sensitivity Coefficient	Uncertainty Contribution
$r_{cc}$	$1.000000000 \cdot 10^{-3}$	$120 \cdot 10^{-12}$	normal	0.67	$80 \cdot 10^{-12}$
$R_s$	$1.000004000 \Omega$	$119 \cdot 10^{-9} \Omega$			
$R_d$	$0.4999448350 \Omega$	$86.7 \cdot 10^{-9} \Omega$			
$\delta_{ratio}$	$-114.200 \cdot 10^{-6}$	$200 \cdot 10^{-9}$	normal	$670 \cdot 10^{-6}$	$130 \cdot 10^{-12}$
$\delta_{scaling}$	$-540 \cdot 10^{-9}$	$270 \cdot 10^{-9}$	normal	$670 \cdot 10^{-6}$	$180 \cdot 10^{-12}$
$\delta_{pos}$	0.0	$173 \cdot 10^{-9}$	rectangular	$670 \cdot 10^{-6}$	$120 \cdot 10^{-12}$
$R_{snom}$	$1.0 \Omega$				
$\delta_{Rs}$	$4.000 \cdot 10^{-6}$	$100 \cdot 10^{-9}$	normal	$670 \cdot 10^{-6}$	$67 \cdot 10^{-12}$
$\delta_{Rstab}$	0.0	$57.7 \cdot 10^{-9}$	rectangular	$670 \cdot 10^{-6}$	$38 \cdot 10^{-12}$
$\delta_{RsT}$	0.0	$28.9 \cdot 10^{-9}$	rectangular	$670 \cdot 10^{-6}$	$19 \cdot 10^{-12}$
$R_{dnom}$	$0.5 \Omega$				
$\delta_{Rd}$	$-110.330 \cdot 10^{-6}$	$150 \cdot 10^{-9}$	normal	$-670 \cdot 10^{-6}$	$-100 \cdot 10^{-12}$
$\delta_{Rdstab}$	0.0	$86.6 \cdot 10^{-9}$	rectangular	$-670 \cdot 10^{-6}$	$-58 \cdot 10^{-12}$
$\delta_{RdT}$	0.0	$5.77 \cdot 10^{-9}$	rectangular	$-670 \cdot 10^{-6}$	$-3.8 \cdot 10^{-12}$
$r_{DUT}$	$666.666393 \cdot 10^{-6}$	$300 \cdot 10^{-12}$			

With as final result:  $r_{DUT-300A} = 666.66639 \cdot 10^{-6} \pm 0.90 \cdot 10^{-6}$  (relative) ( $k = 2$ )

**UNCERTAINTY BUDGET 600 A**

Using the model equation in section 5.1, the following uncertainty budget follows for the 600 A DC primary current calibration:

Quantity	Value	Standard Uncertainty	Distribution	Sensitivity Coefficient	Uncertainty Contribution
$r_{cc}$	$1.000000000 \cdot 10^{-3}$	$120 \cdot 10^{-12}$	normal	0.67	$80 \cdot 10^{-12}$
$R_s$	$1.000003820 \Omega$	$124 \cdot 10^{-9} \Omega$			
$R_d$	$0.2499653500 \Omega$	$68.9 \cdot 10^{-9} \Omega$			
$\delta_{ratio}$	$-142.300 \cdot 10^{-6}$	$250 \cdot 10^{-9}$	normal	$670 \cdot 10^{-6}$	$170 \cdot 10^{-12}$
$\delta_{scaling}$	$-770 \cdot 10^{-9}$	$300 \cdot 10^{-9}$	normal	$670 \cdot 10^{-6}$	$200 \cdot 10^{-12}$
$\delta_{pos}$	0.0	$173 \cdot 10^{-9}$	rectangular	$670 \cdot 10^{-6}$	$120 \cdot 10^{-12}$
$R_{snom}$	$1.0 \Omega$				
$\delta_{Rs}$	$3.820 \cdot 10^{-6}$	$100 \cdot 10^{-9}$	normal	$670 \cdot 10^{-6}$	$67 \cdot 10^{-12}$
$\delta_{Rstab}$	0.0	$57.7 \cdot 10^{-9}$	rectangular	$670 \cdot 10^{-6}$	$38 \cdot 10^{-12}$
$\delta_{RsT}$	0.0	$46.2 \cdot 10^{-9}$	rectangular	$670 \cdot 10^{-6}$	$31 \cdot 10^{-12}$
$R_{dnom}$	$0.25 \Omega$				
$\delta_{Rd}$	$-138.600 \cdot 10^{-6}$	$150 \cdot 10^{-9}$	normal	$-670 \cdot 10^{-6}$	$-100 \cdot 10^{-12}$
$\delta_{Rdstab}$	0.0	$231 \cdot 10^{-9}$	rectangular	$-670 \cdot 10^{-6}$	$-150 \cdot 10^{-12}$
$\delta_{RdT}$	0.0	$8.66 \cdot 10^{-9}$	rectangular	$-670 \cdot 10^{-6}$	$-5.8 \cdot 10^{-12}$
$r_{DUT}$	$666.666233 \cdot 10^{-6}$	$360 \cdot 10^{-12}$			

With as final result:  $r_{DUT-600A} = 666.66623 \cdot 10^{-6} \pm 1.1 \cdot 10^{-6}$  (relative) ( $k = 2$ )

**Supplementary Comparison EURAMET.EM-35  
Comparison of High-Current Ratio Standard**

**FINAL REPORT – ANNEX D  
Technical protocol of the comparison**

C. Cassiago<sup>a</sup> and A. Mortara<sup>b</sup>

a Istituto Nazionale di Ricerca Metrologica, INRIM  
Strada delle Cacce 91, 10135 Turin, Italy

b Federal Institute of Metrology, METAS  
Lindenweg 50, 3003 Bern-Wabern, Switzerland

## **Table of Contents**

Technical protocol of the comparison.

**Supplementary Comparison EURAMET.EM-S35  
Comparison of High-Current Ratio Standard**

**TECHNICAL PROTOCOL**

C. Cassiago<sup>1</sup> and A. Mortara<sup>2</sup>

(1) Istituto Nazionale di Ricerca Metrologica, INRIM  
Strada delle Cacce 91, 10135 Turin, Italy

(2) Federal Office of Metrology, METAS  
Lindenweg 50, 3003 Bern-Wabern, Switzerland

## Contents

1. Introduction .....	3
2. Travelling standard.....	3
2.1 Description of the standard .....	3
2.2 Quantities to be measured .....	3
2.3 Method of computation of the Reference value .....	4
3. Organisation .....	5
3.1 Co-ordinator and members of the support group .....	5
3.2 Participants .....	5
3.3 Time schedule .....	5
3.4 Transportation .....	6
3.5 Unpacking, handling, packing.....	6
3.6 Failure of the travelling standard .....	7
3.7 Financial aspects, insurance .....	7
4. Measurement instructions .....	7
4.1 Measurement performance .....	7
4.2 Method of measurement.....	8
5. Uncertainty of measurement .....	8
5.1 Main uncertainty components .....	8
5.2 Scheme to report the uncertainty budget.....	8
6. Measurement report.....	8
7. Report of the comparison .....	9
References .....	9
Annexes.....	10
A1 Detailed list of participants .....	10
A2 Schedule of the measurements .....	11
A3 Typical scheme for an uncertainty budget .....	12
A4 Layout of the measurement report .....	13
A5 Confirmation note of receipt .....	14
A6 Confirmation note of dispatch.....	15

## 1. Introduction

The scope of the comparison is the validation of NMI CMCs for quantities related to dc high currents (CMC classification 8.7.1, 8.7.2 and 8.7.3), for current values in the range 100 A – 600 A. Previous CCEM and EUROMET comparisons on dc current do not cover the current range exploited in the present comparison.

The procedures outlined in this document should allow for a clear and unequivocal comparison of the measurement results. The protocol was prepared following the CCEM guidelines for key, supplementary and pilot comparisons [1].

## 2. Travelling standard

### 2.1 Description of the standard

<i>Standard details</i>	- Type	:	LEM IT-600 S
	- Serial number	:	8100088322
	- Nominal primary current	:	0 - 600 A
	- Nominal primary to secondary current ratio	:	1/1500
	- Power supply	:	0 V, and $\pm 15$ V

The travelling standard, characterized at METAS, is a zero flux current transformer with embedded electronics. Mechanical and connection details are shown in fig.1.

### 2.2 Quantities to be measured

- Current ratio	:	1:1500	nominal value
- Primary current	:	90 A (mandatory) 300 A (optional) 600 A (optional)	nominal values.
- Secondary current	:	60 mA (mandatory) 200 mA (optional) 400 mA (optional)	
- Supplied voltage	:	0 V $\pm 15$ V	nominal values.
- Environmental condition	:	temperature humidity pressure	it should be measured on the primary current bus bar, as close as possible to the measuring head; no characterization will be done for both quantities, because no significant influence is expected.
- Measurement condition	:	transformer load resistance $R_m$ (ref. fig.1) initial warm up	no primary conductor or bus-bar is supplied; the recommended value is 1 $\Omega$ , however it must not exceed 2.5 $\Omega$ ; the travelling standard should be powered during at least 24 hours in laboratory conditions before starting measurements.

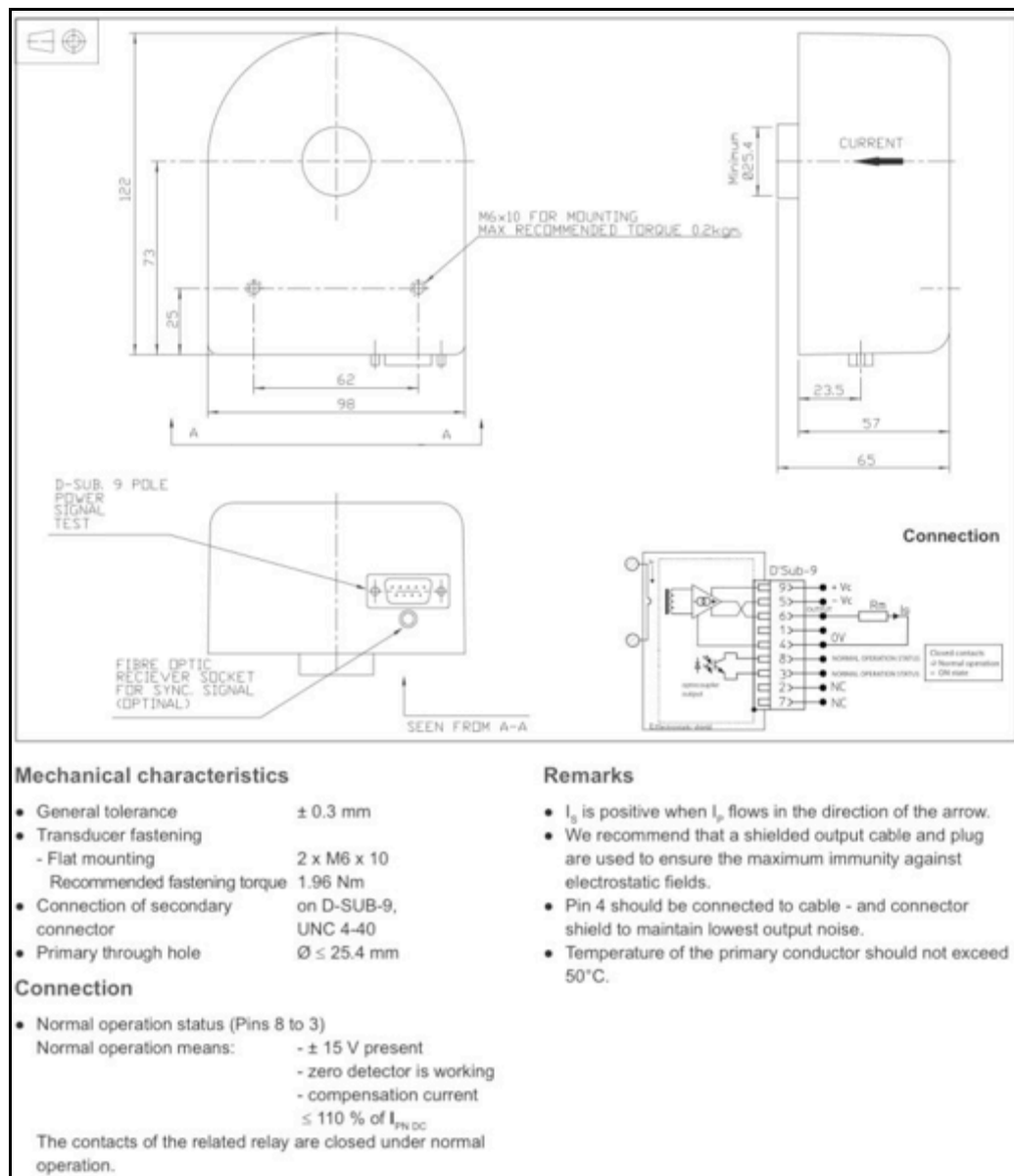

Fig. 1 – LEM IT-600 S current comparator datasheet

### 2.3 Method of computation of the Reference value

The comparison reference value (CRV) will be evaluated following the following principles:

- the results obtained by the pilot laboratory will be used to determine the drift behaviour of the travelling standards;
- the results provided by the participants will be corrected to the nominal temperature (23 °C) using the sensitivity coefficients determined by the pilot laboratory;
- for the calculation of the CRV and the degrees of equivalence, the procedures described in the guideline [2] will be used;
- if for a result, the uncertainty contribution due to the traceability to another NMI amounts to a substantial part of the overall uncertainty value, the result is not taken into account in the calculation of the CRV.

### 3. Organisation

#### 3.1 Co-ordinator and members of the support group

The pilot laboratories for the comparison are the Federal Office of Metrology (METAS) and the Istituto Nazionale di Ricerca Metrologica (INRIM).

Co-ordinator:

Cristina Cassiago (INRIM)  
Istituto Nazionale di Ricerca Metrologica  
Strada delle Cacce 91, 10135 Turin, Italy  
Tel.: +39 011 3919 430; e-mail: c.cassiago@inrim.it

Support group:

Alessandro Mortara (METAS)  
e-mail: alessandro.mortara@metas.ch

Bernd Schumacher (PTB)  
e-mail: bernd.schumacher@ptb.de

JT Janssen (NPL)  
e-mail: jt.janssen@npl.co.uk

#### 3.2 Participants

The following institutes announced the interest to participate in the comparison.

No	Acronym	Institute	Country
1	CMI	Czech Metrology Institute	Czech Republic
2	INRIM	Istituto Nazionale di Ricerca Metrologica	Italy
3	LNE	Laboratoire national de métrologie et d'essais	France
4	METAS	Federal Office of Metrology METAS	Switzerland
5	MIKES	Centre for Metrology and Accreditation	Finland
6	NPL	National Physical Laboratory	United Kingdom
7	PTB	Physikalisch-Technische Bundesanstalt	Germany
8	SIQ	Slovenian Institute of Quality and Metrology	Slovenia
9	SMD	SPF Economie, PME, Classes Moyennes et Énergie - Qualité et Sécurité- Service Etalons	Belgium
10	SP	SP Technical Research Institute of Sweden	Sweden
11	VSL	VSL Dutch Metrology Institute	Netherlands

*Table 1:* Participants

#### 3.3 Time schedule

The comparison is carried out in 2 loops. The circulation of the standard starts in November 2012 and is planned to end in November 2013. The detailed time schedule for the comparison is given in Appendix A2.

A period of 4 weeks is allowed for the measurements in each laboratory, including the time necessary for transportation. It is intended to re-measure the standards at certain intervals in the pilot laboratory to establish a drift rate for the standard and to detect transport problems.

In agreeing with the proposed circulation time schedule, each participating laboratory confirms that it is capable to perform the measurements in the limited time period allocated in the time schedule. If, for some reasons, the measurement facility is not ready or custom clearance should take too much time, the laboratory is requested to contact immediately the co-ordinator. According to the arrangement made in this special case eventually the travelling standard must be sent directly to the next participant before the measurement has been finished or even without performing any measurements. In such a case, there is a possibility to carry out the measurements at the end of the comparison.

If delay occurs, the pilot laboratory shall inform the participants and revise, if necessary, the time schedule, or skip one country and put it at the end of the circulation.

### 3.4 Transportation

Transportation is at each laboratory's own responsibility and cost. Due to the time constraints, a recognised courier service (e.g. UPS, DHL...) guaranteeing an adequate delivery time, including the time for customs procedure, should be used. Where appropriate, customs procedures have to be examined in advance of the transport. The courier service has to be informed that the transport case should not be exposed to extreme temperatures or mechanical shocks.

In some countries, the case will be transported with an ATA carnet for customs clearance. Upon each movement of the package, the person organising the transit must ensure that the carnet is presented to customs on leaving the country, and upon its arrival in the country of destination. When the package is sent unaccompanied, the carnet must be included with the other forwarding documents so that the handling agent can obtain customs clearance. IN NO CASE SHOULD THE CARNET BE PACKED INSIDE THE CASE. In some cases it is possible to attach the carnet to the case. The carnet must be stored in the laboratory very carefully because a loss of the carnet may cause a serious delay in the comparison schedule.

On receipt of the case, the participant shall inform the pilot laboratory by sending the receipt form given in Appendix A5 by fax or e-mail.

Immediately after the completion of the measurements, the case is to be transported to the next participant. It is advisable to organise this transport beforehand. The pilot laboratory has to be informed through the form given in Appendix A6 about the dispatch of the case. The next participant should be informed as well.

### 3.5 Unpacking, handling, packing

The transport case contains the following items:

- Packing list**
- DC Current Comparator LEM IT-600 S
  - Connection cable for power supply and current output, with unequivocally labelled connectors
  - Ambient conditions recorder. This recorder is used to monitor the temperature of the standards during transport.
  - Instruction sheet.

On receipt of the case, unpack the standards carefully and check for any damage and the completeness of the audit pack according to the packing list. The ambient conditions recorder should not be removed from the transport case. If possible, the transport case should be stored in the laboratory. Any damage of the standard or missing item shall be reported on the receipt form to be sent to the co-ordinator.

Before sending the case out, check the packing list and ensure everything is enclosed. The standard should be packed in the original transport case as illustrated in the instruction manual. *Ensure that the ATA carnet (where applicable) is packed outside the case for easy access by customs.*

### 3.6 Failure of the travelling standard

If the standard should be damaged during the comparison, the comparison co-ordinator has to be informed immediately.

### 3.7 Financial aspects, insurance

Each participating laboratory covers the costs of the measurements, transportation and eventual customs formalities as well as for any damage that may occur within its country. The overall costs for the organisation of the comparison are covered by the organising pilot laboratory. The pilot laboratory is responsible for insurance and for any loss or damage of the standard during transportation.

## 4. Measurement instructions

### 4.1 Measurement performance

- Pre-conditioning : the standard should be installed in laboratory at the working temperature, at least 24 h before starting the measurements.
- Temperature :  $(23 \pm 1)$  °C; the temperature should not exceed the given limits.
- Humidity :  $(50 \pm 10)$  %;
- Power supply : the travelling standard must be supplied with 0 V, and  $\pm 15$  V. A power supply is not part of the travelling material. The supplied values should not lay more than 5% away from the nominal value. The measured power supply values must be provided together with the measurement results;
- Measurand : secondary to primary current ratio R defined as follows:

$$R = \frac{I_S - I_{\text{off}}}{I_p} \quad (1)$$

where  $I_p$  is the input current (primary current) flowing in the travelling standard and  $I_S$  the output current (secondary current) of the travelling standard.  $I_{\text{off}}$  is the output current of the travelling standard when the input current is zero. The value of R shall be measured for both polarities at a given current value.

- Results : The measurement results of R shall be given as:  
 $R_+$  = measurement performed with positive current<sup>(1)</sup>,  
 $R_-$  = measurement performed with negative current,  
 $R_M$  = result obtained by averaging  $R_+$  and  $R_-$  measurements or measured in other way (for instance with a direct measurement). In this last case, if  $R_+$  and  $R_-$  can not be evaluate independently it must be declared.

---

<sup>(1)</sup> $I_S$  is positive when  $I_p$  flows in the direction of the arrow on top of the travelling standard (see fig.1).

## 4.2 Method of measurement

The measurement method is not specified. It is assumed that every participant uses its normal measurement method. The method and the traceability scheme have to be described in the measurement report (see below).

## 5. Uncertainty of measurement

### 5.1 Main uncertainty components

A detailed uncertainty budget in accordance with the Guide to the Expression of Uncertainty in Measurement [3] shall be reported for primary current of each nominal value.

To have a comparable uncertainty evaluation, a list of principal uncertainty contributions is given. Depending on the measuring methods, this list may vary and can include:

- reference standard (drift, temperature and current dependence, etc.)
- measuring set-up (stability, gain and offset-effects, electrical configuration, primary current tolerance, etc.)
- measuring method
- tolerances (of primary current, etc...)
- leakage effects
- temperature
- humidity
- reproducibility (centring error, etc...)

In the uncertainty budget for each uncertainty contribute it must be indicated

- probability distribution
- degrees of freedom

If the traceability of the reference standard depends on another NMI, it should be indicated.

### 5.2 Scheme to report the uncertainty budget

A proposed scheme for the uncertainty budget is given in Annex A3.

## 6. Measurement report

Each participant is asked to submit a printed and signed report by mail within **6 weeks after completing** the measurements. A copy of the report together with an Excel worksheet containing the detailed measurement(see Appendix 4), and their Adobe Acrobat copies (printed as PDF/A), are also to be sent by e-mail. In the case of differences between electronic and paper versions of the report, the signed paper form is considered to be the valid version. If the deadline for sending the results is not kept, the concerned laboratory may be excluded from the comparison.

The report should contain at least the following (see also Appendix A4):

- description of the measuring set-up including the electrical circuit configuration;
- traceability scheme; if the traceability to the SI is provided by another NMI, the name of the NMI has to be stated (needed to identify possible sources of correlation);
- description of the measurement procedure;
- the measurement results: mean current value and the corresponding mean date of measurement; individual results in the form described in Appendix A4;
- the ambient conditions of the measurement: the temperature and humidity with limits of variation;
- a complete uncertainty budget in accordance with the principles of the Guide to the Expression of Uncertainty in Measurement [3], including degrees of freedom for every component and calculation of the coverage factor; such an analysis is a prerequisite to be considered in the

calculation of the comparison reference value; it is also an essential part of the final report which will appear in the BIPM Key Comparison Database.

The pilot laboratory will inform the participating laboratory if there is a large deviation between the results of the laboratory and the preliminary reference values. No other information will be communicated before the completion of the circulation.

## **7. Report of the comparison**

The pilot laboratory will prepare the draft A report within three months after completion of the circulation. This report will be prepared with the aid of the support group and will be sent to all participants for comments.

## **References**

- [1] “CCEM Guidelines for Planning, Organizing, Conducting and Reporting Key, Supplementary and Pilot Comparisons”, March 2007, <http://www.bipm.org/en/committees/cc/ccem/guidelines.html>.
- [2] M. G. Cox, “The evaluation of key comparison data”, *metrologia* 39, pp. 589-595, 2002.
- [3] BIPM Guide JCGM 100:2008

## Annexes

### A1 Detailed list of participants

No	Acronym	Institute	Name	e-Mail	Address	Country	Telephone	Telefax
1	CMI	Czech Metrology Institute	Renata Stybliková	rstyblikova@cmi.cz	V Botanice 4 150 72 Prague 5	Czech Republic	+420 257 288 335 +420 602 196 072 (mob)	+420 257 328 0777
2	INRIM	Istituto Nazionale di Ricerca Metrologica	Enrico Gasparotto	e.gasparotto@inrim.it	Strada delle Cacce 91 10135 Turin	Italy	+39 011 3919 438	+39 011 346384
3	LNE	Laboratoire national de métrologie et d'essais	Daniela Istrate	daniela.istrate@lne.fr	Av. Roger Hennequin 78197 Trappes Cedex	France	+33 01 30 69 32 05	+33 01 30 16 24 52
4	METAS	Federal Office of Metrology METAS	Alessandro Mortara	alessandro.mortara@metas.ch	Lindenweg 50 3003 Bern-Waben	Switzerland	+41 31 323 33 28	+41 31 323 32 10
5	MIKES	Centre for Metrology and Accreditation	Jari Hällström	jari.hallstrom@mikes.fi	Tekniikantie 1 02151 Espoo	Finland	+358 10 6054 441	+358 10 6054 498
6	NPL	National Physical Laboratory	Colin Porter	colin.porter@npl.co.uk	NPL Module 2 Hampton Road Teddington Middlesex TW11 0LW	United Kingdom	+44 (0)20 8943 6195	+44 (0)20 8943 7176 +44 (0)20 8614 0499
7	PTB	Physikalisch-Technische Bundesanstalt	Bernhard Schumacher	bernd.schumacher@ptb.de	Bundesallee 100, 38116 Braunschweig	Germany	+49 5315922110	+49 5315922105
8	SIQ	Slovenian Institute of Quality and Metrology	Matjaz Lindic	matjaz.lindic@siq.si	Trzaska cesta 2 1000 Ljubljana	Slovenia	+386 1 4778 310	+386 1 4778 303
9	SMD	SPF Economie, PME, Classes Moyennes et Énergie - Qualité et Sécurité- Service Etalons	Dana Vlad	dana.vlad@economie.fgov.be	Bd Albert II, 16 B1000, Bruxelles	Belgium	+32(0)22 77 89 18	+32(0) 22 77 54 08
10	SP	SP Technical Research Institute of Sweden	Anders Bergman	anders.bergman@sp.se	Box 857 SE-501 15 BORAAS	Sweden	+46 10 5165678	+46 33 125038
11	VSL	VSL Dutch Metrology Institute	Gert Rietveld	grietveld@vsl.nl	Thijssweg 11 2629 JA Delft	The Netherlands	+31 (15) 2691500	+31 (15) 2612971

## A2 Schedule of the measurements

Period	Start date	End date	Laboratory	
	2012/10/29	2012/12/02	Pilot laboratory	
1	2012/12/03	2012/12/30	VSL	Loop 1
2	2013/01/07	2013/02/03	SP	
3	2013/02/04	2013/03/03	MIKES	
4	2013/03/04	2013/03/31	PTB	
5	2013/04/01	2013/04/28	LNE	
	2013/04/29	2013/06/02	Pilot laboratory	
6	2013/06/03	2013/06/30	INRIM	Loop 2
7	2013/07/01	2013/07/28	NPL	
8	2013/09/02	2013/09/29	CMI	
9	2013/09/30	2013/10/27	SIQ	
10	2013/10/28	2013/11/24	SMD	
	2013/11/25	2013/12/22	Pilot laboratory	

**A3 Typical scheme for an uncertainty budget**

Quantity $X_i$	Estimate $x_i$	Standard uncertainty $u(x_i)$	Probability distribution / method of evaluation (A, B)	Sensitivity coefficient $c_i$	Uncertainty contribution $u(R_i)$	Degree of freedom $\nu_i$
$R$						
		Combined standard uncertainty:				
		Effective degrees of freedom:				
		Expanded uncertainty (95% coverage factor):				

The detailed uncertainty has to be provided in this form for  $R+$ ,  $R-$  and  $R_M$  for each nominal value.

#### A4 Layout of the measurement report

1. Measurand
2. Measurement set-up and traceability scheme
3. Measurement procedure
4. Results
  - a. Ambient conditions
    - Temperature: mean value, uncertainty and range of variation
    - Humidity: mean value, uncertainty and range of variation
    - Power supply level: mean value, uncertainty and range of variation
  - b. Data of measurement
  - c. Ratio value, combined standard uncertainty
5. Detailed uncertainty budget

#### Detailed results

*These results have to be supplied using the xls mask supplied by the coordinator*

Date	Primary current (A)	$u(I_P)$ (A)	Secondary current (A)	$u(I_S)$ (A)	Temperature (°C)	$u(T)^{(*)}$ (°C)	Humidity (%)	$u(H)^{(*)}$ (%)	Power supply (V)	$u(PS)^{(*)}$ (V)	Power supply variation (%)	Measurement result (Ratio value)	Combined standard uncertainty (Ratio uncertainty)

(\*) Combined standard uncertainty (incl. type B components)

**A5 Confirmation note of receipt**

***Telefax Telefax Telefax***

(Please pass on immediately!)

**To:** Istituto Nazionale di Ricerca Metrologica (I.N.RI.M.)  
**attn.:** Dott.ssa Cristina Cassiago

Strada delle Cacce 91, 10135 Torino, Italy

**fax:** +39 011 346384

**e-mail:** c.cassiago

**From:** (participating laboratory):

.....  
.....  
.....

**Fax:** *International +*

**Pages (total):** 1

In the case of faulty reproduction, please call:

.....  
.....

---

**Re: Supplementary Comparison EURAMET.EM-S35  
Receipt of travelling standards**

**Date:** .....

We confirm having received the travelling standards on: .....

After visual inspection:

No damage of the suitcase and the travelling standards has been noticed

the following damage(s) must be reported( if possible add a picture):

.....  
.....  
.....  
.....  
.....  
.....  
.....

**Date:** ..... **Signature:** .....

**A6 Confirmation note of dispatch**

***Telefax Telefax Telefax***

(Please pass on immediately!)

**To:** Istituto Nazionale di Ricerca Metrologica (I.N.RI.M.)  
**attn.:** Dott.ssa Cristina Cassiago

Strada delle Cacce 91, 10135 Torino, Italy

**fax:** +39 011 346384

**e-mail:** c.cassiago

**From:** (participating laboratory):

.....  
.....  
.....

**Fax:** *International +*

**Pages (total):** 1

In the case of faulty reproduction, please call:

.....  
.....

---

**Re: Supplementary Comparison EURAMET.EM-S35  
Receipt of travelling standards**

**Date:** .....

We have informed the next participant on .....  
that we will send travelling standards to them.

We confirm having sent the travelling standad on .....  
to the next participant.

**Additional informations:**

.....  
.....  
.....  
.....  
.....  
.....  
.....  
.....

**Date:** ..... **Signature:** .....

**Supplementary Comparison EURAMET.EM-35  
Comparison of High-Current Ratio Standard**

**FINAL REPORT – ANNEX E  
Datasheet of travelling standard**

C. Cassiago<sup>a</sup> and A. Mortara<sup>b</sup>

a Istituto Nazionale di Ricerca Metrologica, INRIM  
Strada delle Cacce 91, 10135 Turin, Italy

b Federal Institute of Metrology, METAS  
Lindenweg 50, 3003 Bern-Wabern, Switzerland

## **Table of Contents**

Datasheet of travelling standard.

# High Performance Current Transducer IT 600-S ULTRASTAB

$$I_{PM} = 0 \dots 600 \text{ A}$$

For the electronic measurement of currents: DC, AC, pulsed..., with galvanic isolation between the primary circuit (high power) and the secondary circuit (electronic circuit).



## Electrical data

$I_{PN}$	Primary nominal current DC	600	A
$I_{PN}$	Primary nominal current rms	425	A
$I_{PM}$	Primary current, measuring range	0 .. $\pm 600$	A
$\hat{I}_P$	Max overload capability 100 ms <sup>1)</sup>	$\pm 3000$	A
$R_M$	Measuring resistance	$R_{M \min}$ $R_{M \max}$	
	Over operating current, temperature and supply voltage range	2.5 2.5	$\Omega$
$I_S$	Secondary current	0 .. $\pm 400$	mA
$I_{SN}$	Secondary nominal current rms	282	mA
$K_N$	Conversion ratio	1 : 1500	
$V_C$	Supply voltage ( $\pm 5\%$ )	$\pm 15$	V
$I_C$	Current consumption $\pm 15\%$	$\leq 200 + I_S$	mA

## Accuracy - Dynamic performance data

$\epsilon_L$	Linearity error <sup>2)</sup>	$\leq 1$	ppm
$I_{OE}$	Electrical offset current + self magnetization + effect of earth magnetic field @ $T_A = 25^\circ\text{C}$ <sup>2)</sup>	$< 20$	ppm
$\Delta I_{OE}$	Offset stability (no load) <sup>2)</sup>	$< 1$	ppm/month
$TCI_{OE}$	Temperature coefficient of $I_{OE}$ ( $10^\circ\text{C} \dots 50^\circ\text{C}$ ) <sup>2)</sup>	$< 0.2$	ppm/K
	Offset vs. power supply stability @ $T_A = 25^\circ\text{C}$ <sup>2)</sup> @ $V_C = \pm 15 \text{ V} \pm 5\%$	$< 1.5$	ppm/% of $V_C = \pm 15 \text{ V}$

## General data

$T_A$	Ambient operating temperature	10 .. + 50	$^\circ\text{C}$
	Humidity (non condensing)	20 - 80 %	RH
$T_S$	Ambient storage temperature	- 20 .. + 85	$^\circ\text{C}$
	Humidity (non condensing)	20 - 80 %	RH
$R_S$	Secondary coil resistance @ $T_A = 25^\circ\text{C}$	28	$\Omega$
$m$	Mass	1	kg

**Notes:** <sup>1)</sup> Single pulse only, not AC.

The transducer may require a few seconds to return to normal operation when autoreset system is running.

<sup>2)</sup> All ppm figures refer to secondary measuring range 400 mA.

## Features

- Closed loop (compensated) current transducer using an extremely accurate zero flux detector
- Electrostatic shield between primary and secondary circuit.

## Special features

- D-Sub 9 pole male output interface connector
- Output indicates the transducer state.

## Advantages

- Very high accuracy
- Excellent linearity
- Extremely low temperature drift
- Wide frequency bandwidth
- High immunity to external electrostatic and magnetic fields interference
- No insertion losses
- High resolution
- Low noise on output signal
- Low noise feedback to main conductor.

## Applications

- Feed back element in high performance gradient amplifiers for MRI
- Feed back element in precision current regulated devices (power supplies...)
- Calibration unit
- Precise and high stability inverters
- Energy measurement
- Medical equipment.

## Application domain

- Industrial and Medical.

## Current Transducer IT 600-S ULTRASTAB

### Isolation characteristics

Between primary and secondary

$V_b$	Rated isolation voltage rms, reinforced isolation	300	V
	Rated isolation voltage rms, single isolation	2000	V
with IEC 61010-1 standards and following conditions			
- Over voltage category III			
- Pollution degree 2			
$V_d$	Rms voltage for AC isolation test, 50/60 Hz, 1 min	4.9 <sup>1)</sup>	kV
$\hat{V}_w$	Impulse withstand voltage 1.2/50 $\mu$ s	9.1	kV
$V_b$	Rated isolation voltage rms, reinforced isolation	600	V
	Rated isolation voltage rms, single isolation	1000	V
with EN 50178 standards and following conditions			
- Over voltage category III			
- Pollution degree 2			
<b>dCp</b>	Creepage distance	10	mm
<b>dCl</b>	Clearance distance	10	mm
<b>CTI</b>	Comparative Tracking Index (Group I)	600	V

If isolated cable is used for the primary circuit, the voltage category could be improved with the following table (for single isolation) (IEC 61010-1 standard):

Cable isolated (primary)	Category
HAR03	2150 V CAT III
HAR05	2250 V CAT III
HAR07	2350 V CAT III

Note: <sup>1)</sup> Between primary and secondary + shield.

### Safety



This transducer must be used in electric/electronic equipment with respect to applicable standards and safety requirements in accordance with the manufacturer's operating instructions.



Caution, risk of electrical shock

When operating the transducer, certain parts of the module can carry hazardous voltage (eg. primary busbar, power supply).

Ignoring this warning can lead to injury and/or cause serious damage.

This transducer is a build-in device, whose conducting parts must be inaccessible after installation.

A protective housing or additional shield could be used.

Main supply must be able to be disconnected.

## Current Transducer IT 600-S ULTRASTAB

### Output noise figures: @ 25°C

Random Noise ppm (rms):

0 – 10 Hz	0 – 10 kHz	0 – 50 kHz
< 0.05	< 3	< 10

Re-injected noise measured on primary cable (DC - 50 kHz) < 10  $\mu\text{V}_{\text{RMS}}$

### Dynamic performance data

**BW** Frequency bandwidth for small signal 0.5 %, of  $I_{\text{PN}}$  (DC) ( $\pm 3$  dB) DC .. > 100 kHz  
**di/dt** di/dt accurately followed > 100 A/ $\mu\text{s}$   
**t<sub>r</sub>** Response time <sup>1)</sup> to 90 % of  $I_{\text{PN}}$  step < 1  $\mu\text{s}$

Note: <sup>1)</sup> With a di/dt of 100 A/ $\mu\text{s}$ .

## Current Transducer IT 600-S ULTRASTAB

### Over current protection - Electrical specification - Status

As soon as electrical saturation appears, the transducer switches from normal operation to over current mode.

This electrical saturation appears in any case beyond 1.1 time the current range. The primary current corresponding to this trip level is related to the temperature inside the transducer.

Under these conditions:

- the contact (operation status) between pin 8 to 3 (of D-SUB-9 connector) switches off, this contact becomes open.
- Fault level (off state)  $I_p > 110\%$  of  $I_{PN\ DC}$
- Max voltage pin 8 to pin 3, off-State 30 V
- Max current pin 8 to pin 3, on-State 6 mA
- Reverse voltage pin 8 to pin 3, off-State 6 V

To maintain safe start-up  $R_M$  must not exceed  $2.5\ \Omega$  during fault condition.

The over current mode remains until the primary current decreases to a value lower than the recovery current.

### Max secondary current versus measuring resistor

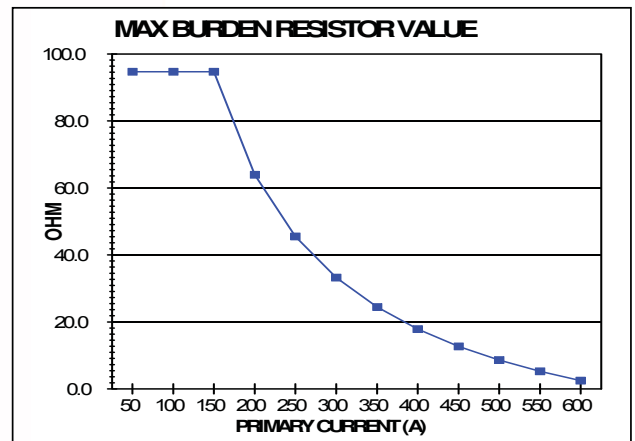
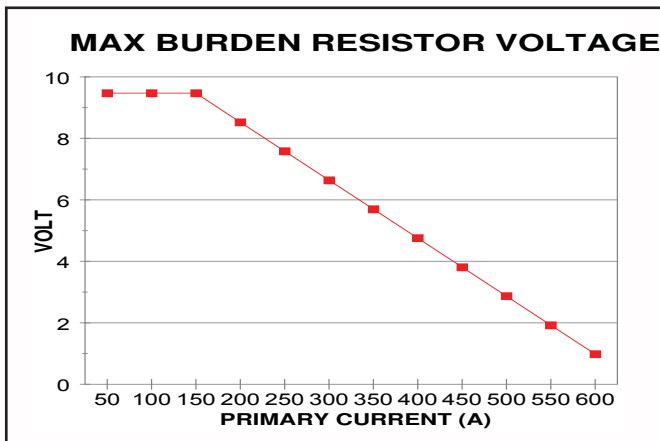

To maintain safe start-up  $R_M$  must not exceed  $2.5\ \Omega$  during fault condition.

### Miscellaneous

Bus bar free zone (length: 75 mm) (from center)

$r \geq 75$

mm

### Dimensions IT 600-S ULTRASTAB (in mm.)

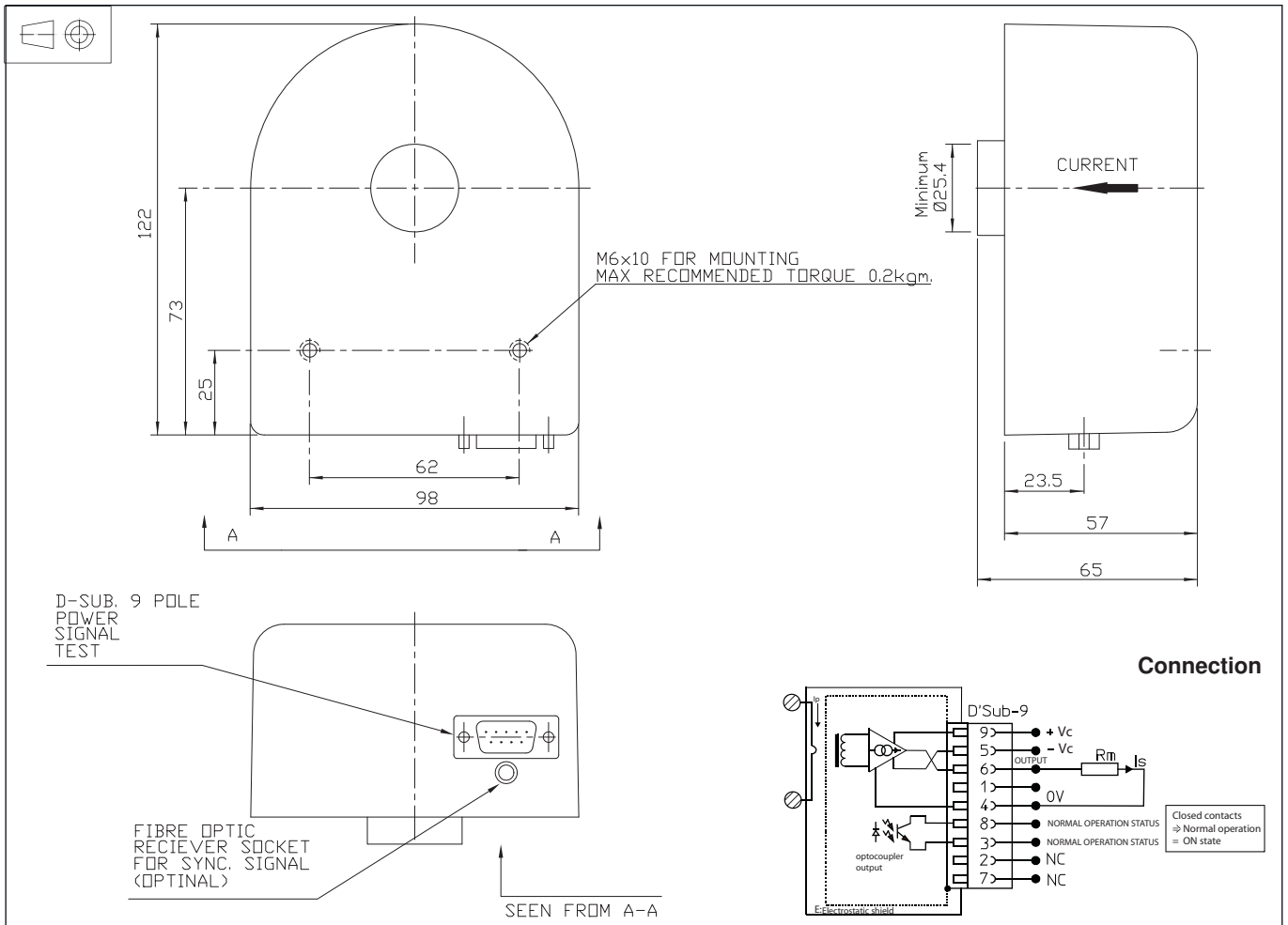

### Mechanical characteristics

- General tolerance  $\pm 0.3$  mm
- Transducer fastening
  - Flat mounting 2 x M6 x 10
  - Recommended fastening torque 1.96 Nm
- Connection of secondary connector on D-SUB-9, UNC 4-40
- Primary through hole  $\varnothing \leq 25.4$  mm

### Connection

- Normal operation status (Pins 8 to 3)
    - Normal operation means:
      - $\pm 15$  V present
      - zero detector is working
      - compensation current  $\leq 110$  % of  $I_{PNDC}$
- The contacts of the related relay are closed under normal operation.

### Remarks

- $I_s$  is positive when  $I_p$  flows in the direction of the arrow.
- We recommend that a shielded output cable and plug are used to ensure the maximum immunity against electrostatic fields.
- Pin 4 should be connected to cable - and connector shield to maintain lowest output noise.
- Temperature of the primary conductor should not exceed 50°C.