

ISTITUTO NAZIONALE DI RICERCA METROLOGICA
Repository Istituzionale

A wireless reference node to provide self-calibration capability to wireless sensors networks

This is the author's submitted version of the contribution published as:

Original

A wireless reference node to provide self-calibration capability to wireless sensors networks / Smorgon, Denis; Fernicola, Vito. - Volume 2016-March, 21 March 2016, Article number 7438418, Pages 335-340(2015), pp. 335-340.

Availability:

This version is available at: 11696/57194 since: 2018-02-13T15:00:59Z

Publisher:

Published

DOI:10.1109/ICSensT.2015.7438418

Terms of use:

Visibile a tutti

This article is made available under terms and conditions as specified in the corresponding bibliographic description in the repository

Publisher copyright

(Article begins on next page)

A wireless reference node to provide self-calibration capability to wireless sensors networks

Development, testing and metrological characterisation of a measurement reference node to support *in situ* self-calibration capabilities in wireless sensors networks (WSNs) used in environmental monitoring applications.

Denis Smorgon, Vito Fericola

Istituto Nazionale di Ricerca Metrologica

INRIM, Torino, Italy

d.smorgon@inrim.it, v.fericola@inrim.it

Abstract—Wireless sensors networks (WSNs) are constantly expanding their application field, from simple two-state measurements (e.g., on/off, proximity detection, etc.) to distributed many-parameter measurements. Commercial WSNs offer a wide range of functions and performance with sensors sometimes achieving accuracy comparable with desktop instrumentation.

However, the advantage of using such sensors for in-situ monitoring is often offset by the need of partially dismantling the network at the time of periodic network nodes calibration. As a result, new reference standards suitable for automatic and in-situ calibration of such sensors networks are needed in order to reduce the calibration cost, the inherent inefficiency and the logistic problems of a laboratory calibration, further exploiting the communication capabilities of a WSN.

This work discusses the development of a wireless reference node (WRN) for the measuring of environment quantity such as air temperature (T) and relative humidity (RH). The module was developed for accurate measurements of additional environment-related quantities whose principle is based on a capacitive sensing mechanism (e.g. pressure, air-flow, moisture, etc...).

The WRN performance was investigated in the temperature range from 0 °C to 40 °C and in the relative humidity range from 10 %rh to about 90 %rh for its potential use as a transfer standard for automatic in-situ calibrations. Some of novelties here reported were patented and are now available to upgrade a basic WSN with an automatic in-situ calibration capability.

Keywords: Humidity, In-field Calibration, Reference Standard, Temperature, Traceability, Wireless Reference Node, Wireless Sensors Networks

I. INTRODUCTION

Wireless sensors networks (WSN) are becoming a widespread reality for environmentally-related monitoring in many scientific and industrial sectors, such as in health, automotive, transport and artworks conservation [1-3].

Wireless remote sensors or nodes (also known as ‘motes’) belonging to a WSN have often a dual use. As a transducer, they can be considered a real measuring instrument; as a transport medium, such as in mesh topology network, they carry and relay the detected measurement into the network.

Considering each mote as a single instrument means that the cost of a WSN calibration can be approximated to a single mote calibration multiplied by the number of motes belonging to the WSN. A WSN calibration can thus be very expensive if traditional laboratory calibration methods are used [4]. A laboratory calibration also implies further costs e.g. dismantling the WSN and backuping it for operation continuity in case of critical process monitoring (e.g. perishable goods storage and transport).

On the other hand, if a WSN is considered as a scattered, widespread, instrument, a new calibration approach would be useful to exploit the inherent WSN capabilities and to bring advantages with respect to the traditional calibration methods.

This work discusses such a calibration approach, which exploits the development of a novel wireless reference node (WRN). Emphasis is put on metrological performance of such device compared with commercial motes and its use as a measurement standard for *in situ* calibration of WSNs.

II. CALIBRATION APPROACHES APPLIED TO THE WSNs

Routine laboratory calibration method applied to WSNs implies large costs and logistic difficulties, because of the need of e.g. a partial dismantling of the network and/or the replacement of nodes.

Calibration by comparison is based on the comparison between the measurements taken from a reference standard (REF) and the device under calibration (DUC).

In laboratory calibration:

- both the DUC and the REF are subjected to the same steady-state condition (within certain limits) thanks to a suitable comparison medium or system.
- the measurements are performed at selected set points, based on the measurement range of the DUC and the comparison medium available.

The major benefits that is expected by a more efficient WSN calibration approach would be to keep in place and in service the network nodes during the calibration operations and to avoid the use of any instrumental comparison medium, whenever it is possible.

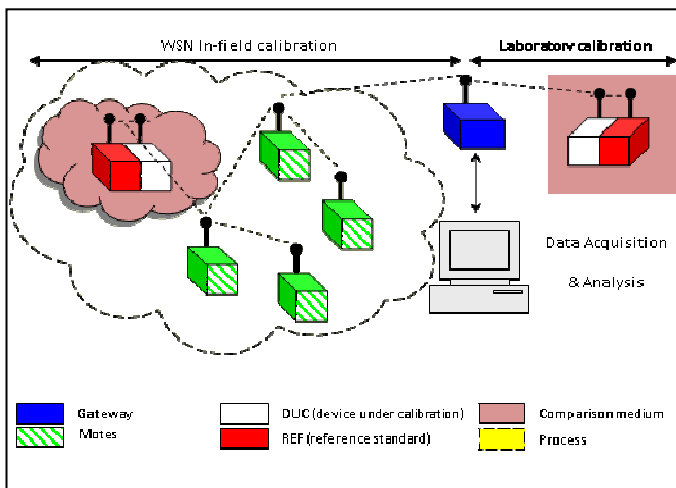

Figure 1. Laboratory vs in situ calibration. Laboratory calibration schemes often include the use of an instrumental comparison medium (pink element), for example a thermostatic chamber, where DUC (in white) and REF (in red) measurements are compared in steady-state conditions. *In situ* calibration approach exploit the environment surrounding REF and DUC as the comparison medium when both are placed conveniently near. When temperature and/or relative humidity are stable within a pre-determined range, an automatic comparison procedure is launched to perform the calibration.

A method to address these requirements, at least for temperature and relative humidity measurements, implies the development of one or more motes with adequate metrological performance, fully integrated into the network, to be used as the reference standard (wireless reference node – WRN) which provide *in situ* self-calibration capability to a WSN.

Figure 1 depicts a schematic of the concept applied to calibration of WSNs in the field in contrast to laboratory calibration.

Such an *in situ* self-calibration capability of a WSN implies the environment surrounding the REF and DUC is considered as the comparison medium when two measurement nodes are brought as close as possible [5]. In fact, within given limits and in absence of significant disturbance, it is reasonable to assume that both devices at short relative distance (<5 cm) are subjected to common climatic conditions. Once estimated, any existing difference in such conditions can be considered as an uncertainty source in the evaluation of the calibration uncertainty.

Bringing a WRN side-by-side to a DUC for a suitable time interval will make available a measurement data set as a basis for the calibration. The procedure can be performed in real time and/or repeated times by any of the component of the network properly instructed to do it, without the need of a central computer or trained personnel to supervise the operation. Any untrained personnel could simply be instructed to periodically move a WRN at different locations to trigger the calibration process of a specific network node. Detailed information about the calibration arrangement and data processing algorithm already are available and patented [6].

The WRN could in fact be any mote of the network, once pre-calibrated in laboratory to provide traceability to relevant SI units. However, commercial motes often suffer by large

unpredictable dependencies from external factors (e.g., self-heating, battery voltage and so on), introducing additional, not negligible, uncertainty contributions and making them unfit for use as a reference node.

The implementation of the proposed calibration capability into a WSN led to the development of a wireless reference node prototype initially used or the measurement of air temperature and relative humidity. A low impact of external influence factors on the measurement accuracy - better than any investigated commercial device - was the aim of the design.

III. INVESTIGATION OF COMMERCIAL MOTES PERFORMANCE

Preliminary to the mote design, an investigation on commercially-available motes was carried out at INRIM. Measurement data collected in such experiments were analysed and considered to be representative of the performance of this class of instrument.

The initial investigation was carried out on a Crossbow MICAZ wireless platform [7]. This WSN platform is largely used in academic and scientific communities because of its easy operation and availability of firmware code; each mote consists of three subsystems: a battery pack, a radio module (RM) and a sensor board (SB). Customers can also develop their own SB and connect it to the RM through a multi-pin connector.

A. Commercial mote characterisation

The metrological characterisation was carried out using a SB model MTS400 which mounts sensors for temperature, relative humidity, barometric pressure, light intensity and local acceleration measurements. The initial characterisation focused on relative humidity (*RH*) and air temperature (*T*) sensors. There were two on-board temperature sensors: the first was embedded with the *RH*-sensor Sensirion model SHT11, while the second with the barometric pressure-sensor Intersema MS5534AM. TABLE I. shows the technical specifications as provided by the sensor manufacturers.

TABLE I. MICAZ MTS400 MOTES. MANUFACTURER SPECIFICATIONS OF THE INVESTIGATED SENSORS

Type sensor	Manufacturer	Model	Meas. Quantity	Range	Resol.	Accuracy
Barometric pressure and temperature	Intersema	MS5534AM	<i>P</i>	300-1100 mbar	0.1 mbar	±1.5% @ 25 °C
			<i>T</i>	-40 +120 °C	0.01 °C	±0.8 °C @ 25 °C
Relative humidity and temperature	Sensirion	SHT11	<i>RH</i>	0-100 %	0.03 %	±3.5%
			<i>T</i>	-40 +125 °C	0.01 °C	±0.5 °C @ 25 °C

The tests were carried out on a small WSN configured for long-term environmental monitoring with a transmission data rate approximately equal to 1 measurement every 180 s. This configuration would insure a battery duration longer than a month for each mote which mounts a model MTS400 sensor board. In order to better investigate possible dependencies from external or parasitic factors, tests at different data rate were also performed.

B. Supply voltage / Battery-discharge dependence

Motes usually have a limited power source, quite often supplied by alkaline-type battery cells; in the case of the MTS400, two AA-style 1.5 V batteries in series were used.

In order to estimate the sensor performance as a function of the battery discharge, four motes were investigated as follows. The devices were introduced in a climatic chamber which maintained stable environmental conditions at a temperature of 0 °C and relative humidity of 50 %. All motes power supply leads were connected in parallel to a single DC power supply source placed outside the climatic chamber. When a chamber temperature stability of better than 10 mK was reached, the power supply voltage was progressively decreased from 3 V to 2.2 V, which corresponds to fully discharged batteries. The motes were programmed to perform measurements at a high data rate (1 measurement every 3 s) in order to get a fast sensor response. The results of this test can be considered data rate independent, with the only caveat that in real operations a higher data rate would correspond to a faster battery discharge.

The test data averaged over the four devices showed for the Sensirion SHT11 sensors a power supply voltage sensitivity of 0.4 °C/V and 0.44 %rh/V for temperature and relative humidity measurements, respectively. The mote manufacturer did not mention such effects. With Intersema MS5534AM temperature sensor, a mean sensitivity coefficient of 0.36 °C/V resulted, while the manufacturer specified a maximum error to within ± 0.2 °C when the supply voltage is between 2.2 V and 3.6 V.

C. Self-heating effect

The self-heating effect is defined here as the temperature increase experienced by the sensor with respect to the actual test chamber temperature, and is due to the Joule effect on the resistance-based sensing element [8] and to the insufficient power dissipation inside the device generated by the electronics. A standard metrology technique used to compensate for such effects is to apply the same instrument settings both during the calibration and the field application. The drawback is that any fixed WSN setting would limit the network flexibility which has often to be re-configured for multiple purposes. For this reason, it is customary that no compensation techniques are used.

The self-heating effect is highly correlated with the data rate. On the other hand, in real environmental monitoring operations at low data rates, e.g. 1 measurement every 180 s, the motes duty cycle is well below 1 %, so it would be reasonable to expect a negligible power dissipation contribution.

Using the same experimental set-up as before, the test started with the external power supply turned off. The transmission data rate was set again at a high data rate as before, i.e. 1 measurement every 3 s. Of course, with this settings the radio transceiver is the most energy-consuming and heat-producing component aboard, as it remains turned on for about 30 % of a measurement cycle.

The average deviations of the temperature and relative humidity readings due to the self-heating effect are 0.64 °C and -2.3 %rh, respectively. The RH reading deviation is consistent with a local temperature increase of 0.64 °C at 50 %rh.

D. Mote calibration

Finally, a full calibration of four MTS400 motes was carried out to complete the investigation on the measurement performance of the sensor. It was carried out between 10 %rh and 90 %rh at constant air temperatures of 10 °C, 20 °C and 40 °C, respectively. The measurement uncertainty was estimated by taking into account the calibration uncertainty contribution and the individual components deriving from the reported investigation [9]. The measurement uncertainty, as reported in TABLE II and TABLE III, are referred to the on-board Sensirion SHT11 sensor. A similar uncertainty budget has been compiled for the Intersema temperature sensor but not here reported.

TABLE II. RH MEASUREMENT UNCERTAINTY IN THE RANGE 10 %RH TO 90 %RH AT 25 °C

Uncertainty Source	Value	Sensit.	PDF ^a	Divisor	St.Dev.
Reference standard	0.25	1	Normal	1	0.25
MOTE repeatability	0.35	1	Normal	1	0.35
MOTE resolution	0.01	1	Rect.	3.46	0.00
MOTE linearity and hysteresis	2.36	1	Normal	1	2.36
MOTE self-heating effect	2.31	1	Rect.	1.73	1.34
MOTE battery-discharge effect	0.6 V	0.44 %rh/V	Rect.	1.73	0.15
Combined standard uncertainty, %rh					2.7
Expanded uncertainty U_{95} , %rh					5.5

a. Probability distribution function

TABLE III. TEMPERATURE MEASUREMENT UNCERTAINTY IN THE RANGE 10 °C TO 40 °C

Uncertainty Source	Value	Sensit.	PDF ^a	Divisor	St.Dev.
Reference standard	0.04	1	Normal	1	0.04
MOTE repeatability	0.03	1	Normal	1	0.03
MOTE resolution	0.09	1	Rect.	3.46	0.00
MOTE fitting	0.09	1	Normal	1	0.09
MOTE self-heating effect	0.64	1	Rect.	1.73	0.37
MOTE battery-discharge effect	0.6 V	0.4 °C/V	Rect.	1.73	0.14
Combined standard uncertainty, °C					0.4
Expanded uncertainty U_{95} , °C					0.8

a. Probability distribution function

The calibration results reported in Figure 2 show large deviations of the MOTE RH-sensor readings, with respect the reference standard, between -8 %rh to -8%rh, i.e. much larger than the manufacturer specifications. The temperature calibration results show an agreement with the specifications. It is likely that such a poor performance of the RH sensor is due to the low data rate chosen, as the sensor turned on for a short time and carried out measurements before having reached an equilibrium condition. This can be noticed from the large uncertainty component associated to the sensor performance,

i.e. the polynomial correction, linearity and hysteresis, which is twice the uncertainty component obtained at high data rates.

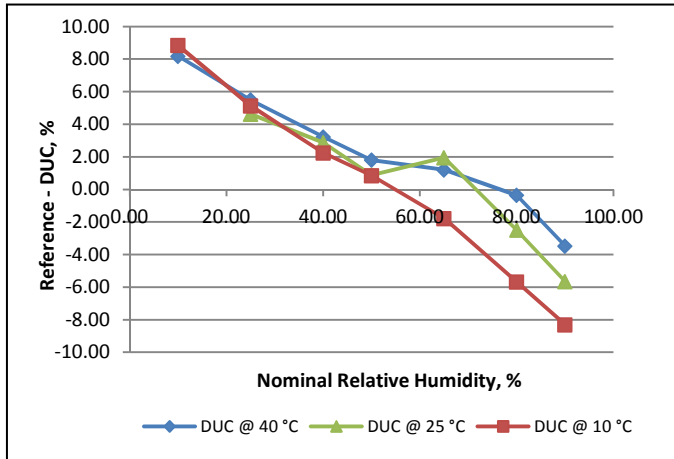

Figure 2. MOTE RH-sensor calibration deviations

IV. PROJECT REQUIREMENTS

The above preliminary study identified the relevant external factors affecting temperature and relative humidity measurements of a commercial WSN sensor board. Small board size and, consequently, large heat density together with a low measurement data rate caused considerable measurement errors. It is not possible to systematically eliminate these limitations, unless a static network operation is chosen (e.g. steady-state measurements, fixed data rate and long waiting time). A fast battery discharge and less network flexibility would be the expected drawback.

Based on the investigation, the design of a novel reference node with improved performance and capability was undertaken. The goal was to minimise the impact of the above influence factors, thus improving the measurement uncertainty, in order to provide self-calibration capability to WSNs.

The following device specifications were targeted: RH measurement range between 5 %rh and 95 %rh with a resolution of 0.01 %rh and measurement uncertainty to within 1.5 %rh; temperature measurement range between -20 °C and 60 °C with a resolution of 0.01 °C and measurement uncertainty to within 0.2 °C.

V. DEVELOPMENT OF THE WRN PROTOTYPE

A. WRN overview

The WRN consists of four stacked blocks: a battery pack, a radio module RM, a general purpose data acquisition module MDA (all included in the MICAZ platform) and the novel reference sensors board (RSB). The RM provides the μ C, the radio transceiver and a storage memory. This memory was also used to store the calibration data (calibration coefficients and uncertainties) to enable the WRN to exchange measurement data and their associated uncertainty over the network.

MDA adds additional analog and digital input/output. It was used to digitally interface the radio module with the RSB and to monitor the battery voltage by means of the onboard AD converter. The RSB also includes a power management circuit.

Oshows the WRN assembly, where at the bottom lies the 7.5 V Li-ion battery, the radio module hidden by the MDA board and, on top, the RSB.

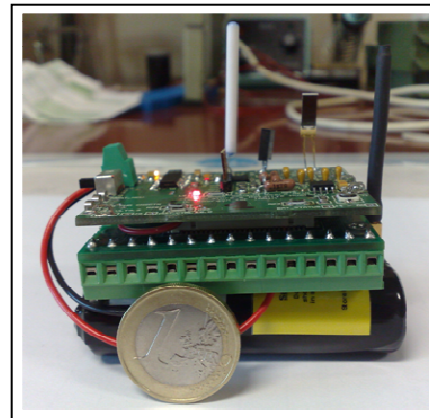

Figure 3. Photo of the assembled WRN prototype

B. Reference Sensor Board development

The RSB measurement principle is based on a commercial capacitance-to-digital converter (CDC) [10]. The CDC is an integrated circuit based on a 24-bit $\Sigma\Delta$ de/modulator with a full-scale range of ± 4.1 pF, a resolution of 4 aF, a specified accuracy of ± 4 fF and a linearity error within ± 0.01 %.

1) Humidity measurement system

To overcome the present limit of the CDC capacitance span (8.2 pF) in such a way to cover the measurement interval of any potential capacitive sensor, a suitable “offset and scaling” technique was applied. A network divider consisting of two scaling resistors made a partition of the excitation voltage across the sensor (Figure 4) in order to widen the measurement interval. An offset capacitor C_{off} offsets the input span in order to fit the capacitance range to a specific sensor.

Figure 4. Simplified schematic of the offset and scaling technique of the

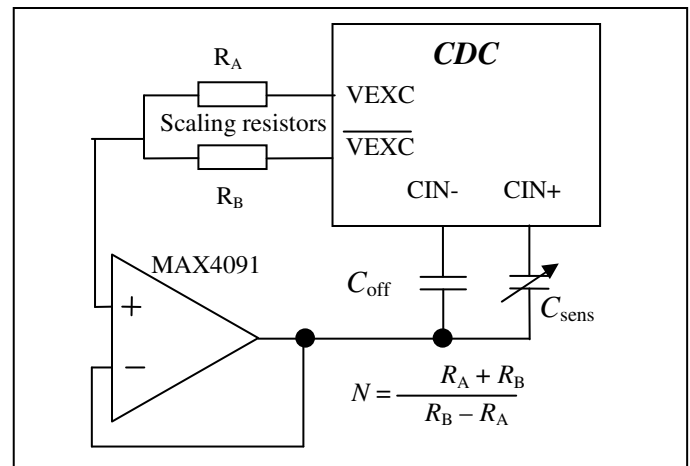

capacitive sensing input. The capacitance-to-digital converter (CDC) has a input capacitance full range of 8.2 pF so a scaling circuit, acting on the sensor excitation voltage, was needed to fit the input range to the RH sensor.

Since the scaling function is not provided originally by the CDC, its basic measurement range stay unchanged. The scaling resistors reduce by N (the scale factor) the difference

$(C_{\text{sens}} - C_{\text{off}})$, in order to keep the ratio $(C_{\text{sens}} - C_{\text{off}})/N$ within the ± 4.1 pF input span. The new measurement range is obtained by:

$$C_{\text{off}} - (4.1 \times N) \leq C_{\text{sens}} \leq C_{\text{off}} + (4.1 \times N) \quad (1)$$

with C_{sens} the sensor capacitance.

The thermal performance of the system could be compromised if the scaling resistors and the offset capacitor were not stable in temperature. To keep this effect negligible, low temperature coefficient (TC) components were chosen. Metal-film resistors with tolerance of 0.1% and TC of ± 25 ppm/ $^{\circ}\text{C}$ [11] and ceramic-type NPO capacitors with a TC of 0 ± 30 ppm/ $^{\circ}\text{C}$ in the range from 55 $^{\circ}\text{C}$ to $+125$ $^{\circ}\text{C}$ are deemed suitable for such purpose.

A high-accuracy polymer capacitive humidity sensor was chosen as the sensing element for the environmental relative humidity [12].

2) Temperature measurement system

The CDC provided a 21-bit $\Sigma\Delta$ modulator A/D converter at its auxiliary input. A resistive half-bridge network was implemented [13] to measure a Pt-100 temperature sensor. A stable 5V voltage reference [14] and a 5- k Ω reference resistor (R_{REF}). R_{REF} value was chosen to limit the self-heating effect in the sensing element. In the temperature range between -20 $^{\circ}\text{C}$ and $+100$ $^{\circ}\text{C}$ the current flowing in the Pt100 was approximately 1 mA.

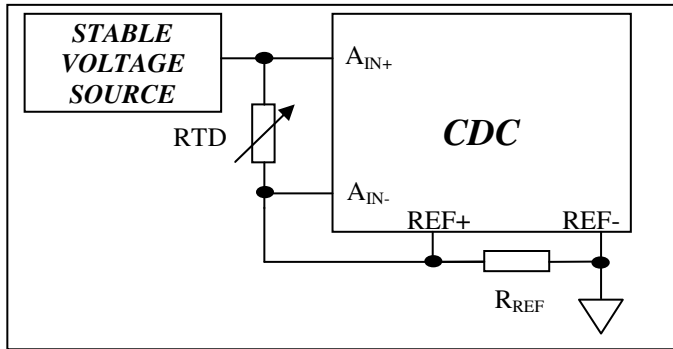

Figure 5. Temperature measurement scheme. Using the CDC as a 21-bit A/D converter it is possible to exploit the auxiliary input to connect a resistive half-bridge network to measure the voltage drop across a reference resistor and the RTD sensor (Pt100)

For environmental monitoring applications, R_{REF} must have a temperature coefficient lower than 1 ppm/ $^{\circ}\text{C}$ and a stability lower than 20 ppm/year (corresponding to a temperature stability ≤ 5 mK) [11]. The nominal resolution of the system is 2.4 m Ω which corresponds to about 6 mK in temperature unit. The experimental repeatability assessed by measuring a stable reference resistor is about 14 m Ω which corresponds to 0.036 $^{\circ}\text{C}$ in temperature unit.

C. WRN settings and techniques for reducing external factors dependence.

A WRN must be fully integrated into a network, but can still be considered as a special node, since it is on service only for node calibration, for a limited operational time, i.e. it is designed to be used for a limited time (a node calibration

period) and not necessarily optimised for energy saving. On the other hand, it was designed to operate with fixed settings and programmed to send data at constant data rate after a minimum warm-up time. Furthermore, fixed settings allow for compensation of self-heating, as the laboratory calibration and the field measurements are performed in the same conditions.

To minimise the device dependence from battery discharge effect, a circuitry monitors the battery voltage by means of an A/D converter on the MDA; when the voltage is below a certain threshold, the measurement data are either discarded by software or an alarm message is sent to the receiving station.

VI. METROLOGICAL CHARACTERISATION OF THE REFERENCE SENSOR BOARD

The characterization of the WRN focused mainly on the evaluation of its RSB (i.e. without connection to the wireless platform). Data from the RSB were acquired by a wired connection. The results are however representative of the whole WRN, as the missing modules cannot significantly affect the RSB performance.

The characterisation and calibration were carried out in a climatic chamber. To tests the dependence on external factors, the same test pattern discussed in section III were followed, with a measurement data-rate of 0.2 Hz.

A. Self-heating effects on temperature and humidity measurements

The tests were carried out in a climatic chamber at 0 $^{\circ}\text{C}$. No effects were detected on temperature measurements and a maximum error of -1.55 %rh after about a 3.5-min warm up was found on relative humidity measurements. Likely, such effects could be larger, also influencing the temperature sensor, if the RSB was mounted on its wireless platform, because of heat dissipated by the platform components; by characterising the RSB only, the results are platform-independent and in any case this effect can be totally compensated for during a calibration. This test showed that the node minimum warm-up time is approx. 3.5 min.

B. Dependence on power supply / battery discharge

The dependence on battery discharge to temperature and RH measurement values were evaluated by varying the voltage across the RSB from 10 V to 6 V, while the RSB was kept at constant temperature and humidity. No effects were detected until the voltage was larger than 6 V, so this value was considered as the voltage threshold for an accurate node operation.

C. Calibration results

TABLE IV. reports the measurement data for a calibration carried out on relative humidity and air temperature sensors onboard the RSB. Data in columns RH_{RSB} and T_{RSB} were converted from their original readings (capacitance and resistance units, respectively) by applying the calibration correction function.

D. Uncertainty analysis

TABLE V. and the TABLE VI. report the estimate of the measurement uncertainty evaluated by the calibration.

The expanded uncertainty U ($k=2$) for relative humidity is slightly less than 1 %, in agreement with the design requirements. The expanded uncertainty for temperature is equal to 0.1 °C, in line with the design requirements.

The present uncertainty budget does not include contributions from self-heating and battery-discharging dependence because they are compensated for.

TABLE IV. REFERENCE SENSOR BOARD CALIBRATION RESULTS

RH_{REF} (%rh)	RH_{RSB} (%rh)	$RH_{RSB} - RH_{REF}$ (%rh)	T_{REF} (°C)	T_{RSB} (°C)	$T_{RSB} - T_{REF}$ (°C)
10.00	9.77	-0.24	0.71	0.70	-0.01
25.00	25.07	0.07	10.85	10.86	0.01
40.00	40.00	0.00	25.60	25.59	-0.01
50.00	49.54	-0.46	40.48	40.48	0.00
65.00	64.82	-0.17			
80.03	79.93	-0.10			
90.01	90.14	0.13			
65.00	65.17	0.17			
50.00	50.19	0.19			
25.00	25.42	0.42			

TABLE V. RSB RELATIVE HUMIDITY SENSOR CALIBRATION UNCERTAINTY BETWEEN 10 %RH AND 90 %RH AT 25 °C

Uncertainty Source	Value	Sensit.	PDF	Divisor	St.Dev.
Reference standard	0.25	1	Normal	1	0.25
RSB/WRN resolution	0.01	1	Rect.	3.46	0.00
RSB/WRN repeatability	0.25	1	Normal	1	0.25
RSB/WRN fitting, linearity & hysteresis	0.29	1	Normal	1	0.29
Combined standard uncertainty, %rh					0.46
Expanded uncertainty U_{95} , %rh					0.91

TABLE VI. RSB TEMPERATURE SENSOR CALIBRATION UNCERTAINTY BUDGET BETWEEN 0 °C AND 40 °C

Uncertainty Source	Value	Sensit.	PDF	Divisor	St.Dev.
Reference standard	0.04	1	Normal	1	0.04
RSB/WRN resolution	0.01	1	Rect.	3.46	0.00
RSB/WRN repeatability	0.03	1	Normal	1	0.03
RSB/WRN fitting	0.02	1	Normal	1	0.02
Combined standard uncertainty, °C					0.05
Expanded uncertainty U_{95} , °C					0.10

VII. CONCLUSIONS

The work presented the development of a wireless reference node (WRN) for measuring air temperature and relative humidity. Its main application is to provide *in situ* reference standards to WSNs in such a way to provide automatic in-field calibration capability to the network. The ensuing calibration approach would not use instrumental comparison media, but exploits the environment surrounding the node under calibration as the comparison medium when a node and the WRN are placed side by side for a pre-determined time.

The developed prototype is made of a novel custom-made reference sensor board connected to a commercial radio

platform manufactured by Crossbow (MICAZ). The design and development of the WRN followed an experimental analysis of the commercial nodes, to obtain their actual measurement performance and design an improved sensor system.

A metrological characterisation was finally performed on the WRN prototype. The resulting expanded uncertainty ($k = 2$) was within 1 %rh for the relative humidity measurements and within 0.1 °C for air temperature measurements. The measurement uncertainties are considerably lower than those obtained by commercial nodes.

These results make the WRN suitable for use as a reference instrument for nodes calibration according to the proposed WSN self-calibration approach. The calibration method and the WRN were patented [6].

REFERENCES

- [1] D. Culler, D. Estrin, M. Srivastava, in IEEE Computer Society, 2004, Vol. 37, Issue 8 Page(s): 41- 49.
- [2] Mike Horton, John Suh, in IEEE XPLORE, 2005, code: 0-7803-8846-1/05.
- [3] Pradnya Gajbhiye, Anjali Mahajan, in IEEE XPLORE, 2008, code: 978-1-4244-2624-9/08.
- [4] D. Smorgon, V. Fericola, in Proceedings of: Traceability to support CIPM MRA and other international arrangements (Torino 6-7 November 2008), workshop organized by IMEKO TC8.
- [5] Smorgon Denis' Ph.D. Thesis available at Politecnico di Torino.
- [6] Italian Patent. TO2011A000503/1406260 08/06/2011
- [7] <http://www.memsic.com/products/wireless-sensor-networks/sensor-boards.html>
- [8] EN ISO 60751 ed. 2.0, Industrial platinum resistance thermometers and platinum temperature sensors (2008).
- [9] ISO CEI UNI ENV 13500, Guide to the expression of uncertainty in measurement, 1995, also known as GUM.
- [10] <http://www.analog.com/en/analog-to-digitalconverters/adconverters/ad7745/products/product.html>
- [11] www.vishaypg.com/docs/63102/smrxd.pdf
- [12] D. Smorgon, V. Fericola, in Proceedings of: VI° Congresso "Metrologia & Qualità" (Torino, 7-9 April 2009).
- [13] D.Smorgon , V.Fericola, L.Coslovi, in International Journal of Thermophysics, 2011, DOI 10.1007/s10765-011-1093-9.
- [14] <http://www.linear.com/product/LT1019>