



## ISTITUTO NAZIONALE DI RICERCA METROLOGICA Repository Istituzionale

Sensing dynamic forces by Fe-Ga in compression

This is the author's accepted version of the contribution published as:

*Original*

Sensing dynamic forces by Fe-Ga in compression / Zucca, Mauro; Mei, Pasquale; Ferrara, Enzo; Fiorillo, Fausto. - In: IEEE TRANSACTIONS ON MAGNETICS. - ISSN 0018-9464. - (2017), pp. 1-4.  
[10.1109/TMAG.2017.2701859]

*Availability:*

This version is available at: 11696/55127 since: 2024-11-08T12:58:27Z

*Publisher:*

IEEE

*Published*

DOI:10.1109/TMAG.2017.2701859

*Terms of use:*

This article is made available under terms and conditions as specified in the corresponding bibliographic description in the repository

*Publisher copyright*

IEEE

© 20XX IEEE. Personal use of this material is permitted. Permission from IEEE must be obtained for all other uses, in any current or future media, including reprinting/republishing this material for advertising or promotional purposes, creating new collective works, for resale or redistribution to servers or lists, or reuse of any copyrighted component of this work in other works

(Article begins on next page)

# Sensing dynamic forces by Fe-Ga in compression

Mauro Zucca<sup>1</sup>, IEEE Member, Pasquale Mei<sup>2</sup>, Enzo Ferrara<sup>1</sup> and Fausto Fiorillo<sup>1</sup>

<sup>1</sup>Istituto Nazionale di Ricerca Metrologica (INRIM) – Strada delle Cacce, 91 – 10135 Torino, Italia  
<sup>2</sup>Dipartimento Energia – Politecnico di Torino – Corso Duca degli Abruzzi, 24 – 10129 Torino, Italia

This paper concerns the sensing of dynamic force/stress by means of a measuring system based on the use of an Fe-Ga sample (Galfenol) coupled to a magnetic circuit. The study is focused on the measurement of the effective magnetic field, detected at the rod specimen surface, and its variation  $\Delta H_{\text{eff}}$  under time-dependent applied sinusoidal stress  $\Delta\sigma$ , oscillating at frequencies between 5 Hz and 20 Hz at different values of applied bias field  $H_{\text{bias}}$  ( $2.5 \text{ kA/m} \leq H_{\text{bias}} \leq 27 \text{ kA/m}$ ). For the considered frequency and  $H_{\text{bias}}$  range, the measured  $\Delta H_{\text{eff}}$  tends to linearly depend on  $\Delta\sigma$ , in contrast with the corresponding induction variation behavior ( $\Delta B - \Delta\sigma$ ), where hysteresis effects appear. With  $\Delta\sigma$  in the range  $\pm 15 \text{ MPa}$  we obtain 0.06 MPa resolution in the determination of the alternating stress  $\Delta\sigma$ , a result pointing to the effectiveness and sensitivity of this Galfenol-based method for detection and measurement of time-dependent stresses.

*Index Terms*— Magnetostrictive devices, Force sensors, Fe-Ga alloy, Stress.

## I. INTRODUCTION

GIANT magnetostrictive materials are characterized by high compressive strength and high Curie temperatures, while being capable of operating in harsh environment [1], [2]. These properties make them suitable for various applications, such as energy harvesting, force sensors, and transducers [3]-[5], where one can take advantage of their bidirectional magnetomechanical response [6].  $\text{Fe}_{81}\text{Ga}_{19}$  (Galfenol) shows a high magnetic saturation value ( $J_s \sim 1.7 \text{ T}$ ), high magnetomechanical coupling, and low remanence with a narrow hysteresis loop [7]. These properties make it a good candidate for sensing forces compared with other giant magnetostrictive materials, such as Terfenol-D [8].

The fact that a variation of a magnetic quantity can be assessed as a function of a mechanical variation, has been exploited for sensing and control of static forces [8]-[10]. Only recently, however, extended experiments on dynamic sensing using Galfenol cores have been performed [11], [12]. In these works, the magnetic flux variation detected by a pickup coil on the core was related to the variation of the applied stress.

Two main limitations appear, however, when choosing the magnetic flux as a stress gauge quantity: 1) the method works better at relatively high frequencies, usually above 100 Hz; 2) the detected flux is generally affected by hysteresis, that is, non-linear response and a substantial frequency-dependent phase shift between measured induction and force.

In this paper, we discuss magnetic sensing of dynamic forces using a Galfenol sample. In particular, effective field and magnetic induction have been measured between 5 Hz and 20 Hz on a Galfenol rod subjected to a

stress cyclically varying around a defined compressive prestress. A dynamic test machine is employed, in connection with a soft magnetic structure, which holds the sample in a flux-closing configuration and imparts a DC field of variable strength. A quasi-linear dependence of the effective magnetic field, measured at the sample surface, on the dynamic stress is observed upon a defined range of bias field values. Besides good linear response and negligible hysteresis, a sensitivity of 0.02 MPa/(A/m) is obtained, resulting in high resolution (0.06 MPa in the range  $\pm 15 \text{ MPa}$ ) at the lowest frequency.

## II. EXPERIMENTAL SETUP AND MATERIAL CHARACTERIZATION

The polycrystalline Galfenol rod ( $\text{Fe}_{81}\text{Ga}_{19}$ ) sample under test (diameter 12 mm, length 60 mm) was inserted as the central limb of a three-legged magnetizer with two identical windings, a scheme similar to the one recently proposed in [12]. The laminated yoke is realized with 0.20 mm thick non-oriented Fe-Si sheets. With a current of 6 A flowing in the two series-connected 550-turn coils, the material can reach saturation even under high applied compressive stress ( $\sim 80 \text{ MPa}$ ), as demonstrated by the Finite Element Method (FEM) simulation shown in Fig. 1. The rod ends are affixed to the compression plates of a 10 kN dynamic test machine (Instron, model E10000, Instron Corp., Norwood, MA, USA), which can work up to 100 Hz. The whole excitation and measuring setup (Fig.

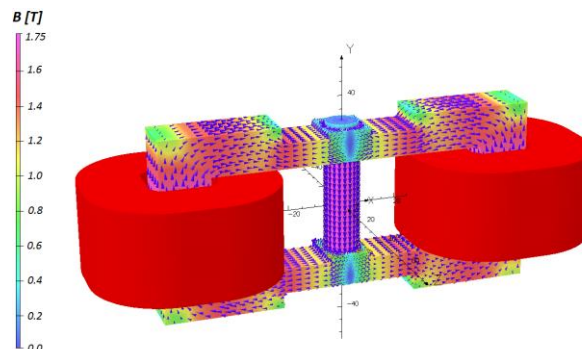

Fig. 1. FEM analysis of the magnetic flux in the employed magnetizer and the Galfenol rod sample with a current of 6 A circulating in the electrical series-connected 550-turn windings.

Manuscript received April 1, 2015; revised xxxxxxx; accepted xxxxxxx. Date of publication xxxxxxxx; date of current version xxxxxxxx. Corresponding author: M. Zucca (e-mail: m.zucca@inrim.it). If some authors contributed equally, write here, "F. A. Author and S. B. Author contributed equally."

Digital Object Identifier (inserted by IEEE).

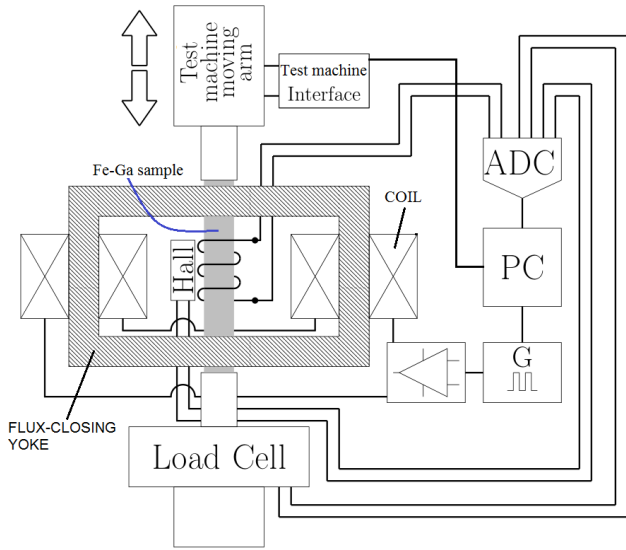

Fig. 2. Scheme of the experimental setup.

2) includes: i) a Lake-Shore magnetometer with Hall field-sensing plate (transverse probe) placed in contact with the Galfenol rod surface at midplane (Gaussmeter model 460, Lake Shore Cryotronics, Inc., Westerville, OH, USA); ii) a 40-turn secondary pickup coil localized at the Hall probe position; iii) a load cell for the measurement of the dynamic force; iv) a computer-controlled data acquisition system using a four-channel oscilloscope as a digitizer (model TDS 420, Tektronix Inc., Beaverton, Oregon, USA) operating in high-resolution mode. The measurement system is schematically shown in Fig. 2. The measured evolution of the quasi-static major hysteresis loops of the Galfenol sample under constant compressive stress ( $-80 \text{ MPa} \leq \sigma_0 \leq 0$ ) is shown in Fig. 3. It is observed how the slope of the magnetization curve around the demagnetized state is progressively depressed upon the increase of the stress.

### III. THE SPECIMEN AS A FORCE SENSOR

An effective bias field up to  $H_{\text{bias(max)}} = 30 \text{ kA/m}$  was axially imposed to the Galfenol rod. At the same time, a constant compressive stress  $\sigma_{\text{bias}} = -45 \text{ MPa}$  (mechanical bias) with sinusoidal modulation of peak amplitude  $\Delta\sigma_{\text{max}} = \pm 15 \text{ MPa}$  and frequency ranging between 5 Hz and 20 Hz was applied by the dynamic test machine.

The mechanical bias stress  $\sigma_{\text{bias}}$  is first imposed by the test machine to the Galfenol specimen. Then, the bias field  $H_{\text{bias}}$  is set, by tuning the electric current that feeds the coils. Then, a sinusoidal variation  $\Delta\sigma$  of the mechanical stress is applied. The associated variation of the effective magnetic field, measured on the sample surface versus the applied bias field, is called  $\Delta H_{\text{eff}}$  in the following.  $\Delta B$  is the corresponding variation of the magnetic induction. An example of the obtained results is given in Fig. 4. It shows the dependence of the effective field variation  $\Delta H_{\text{eff}}$  on the sinusoidal stress  $\Delta\sigma$  as a function of the magnetic field bias  $H_{\text{bias}}$  in the range  $2.5 \text{ kA/m} \leq H_{\text{bias}} \leq 27 \text{ kA/m}$ . Remarkably,  $\Delta H_{\text{eff}}$  appears to linearly depend on  $\Delta\sigma$ , while exhibiting maximum swing with

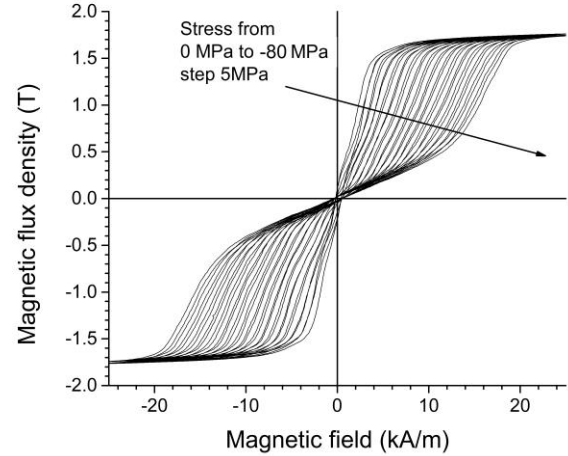

Fig. 3. Quasi-static hysteresis cycles of Galfenol measured under constant compressive stress in the range  $-80 \text{ MPa} \leq \sigma \leq 0$  in 5MPa steps.

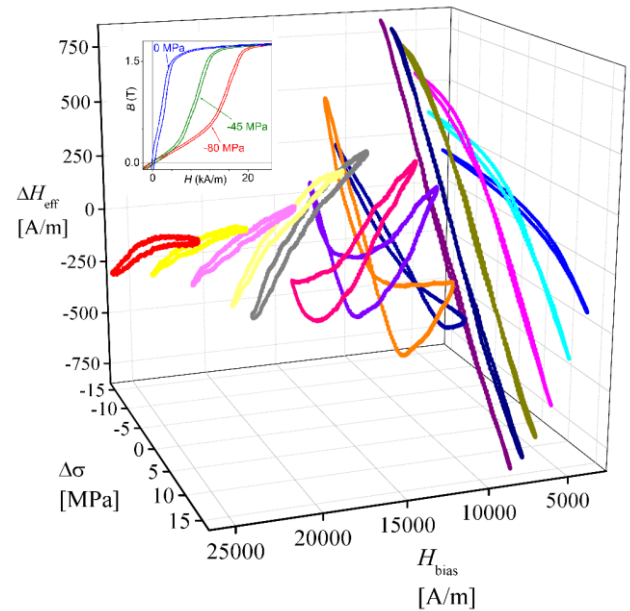

Fig. 4. Measured effective field variation  $\Delta H_{\text{eff}}$  versus dynamic stress  $\Delta\sigma$  at 20 Hz for different values of the applied field bias  $H_{\text{bias}}$ . Compressive pre-stress  $\sigma_{\text{bias}} = -45 \text{ MPa}$ , dynamic stress peak amplitude  $\Delta\sigma_{\text{max}} = \pm 15 \text{ MPa}$ . The inset shows examples of major  $(B, H)$  hysteresis loops measured with constant pre-stress  $\sigma_0 = 0, \sigma_0 = -45 \text{ MPa}; \sigma_0 = -80 \text{ MPa}$ .

negligible hysteresis, in the range of bias field values  $6.5 \text{ kA/m} \leq H_{\text{bias}} \leq 8.5 \text{ kA/m}$ .

#### A. Discussion

We can qualitatively understand the evolution of the  $\Delta H_{\text{eff}}$  versus  $\Delta\sigma$  curves in the polycrystalline Galfenol sample (cubic grains with  $\langle 100 \rangle$  easy axes) looking, on the one hand, at the magnetization process engendered by a changing stress and, on the other hand, at the way the stress-dependent sample permeability affects the behavior of the magnetic circuit. With an applied compressive stress and in the absence of an applied field, the magnetization in the single domains tends to lie along the easy axes farther apart from the direction of the stress (the rod axis). If the compressive  $\sigma_{\text{bias}}$  is sufficiently

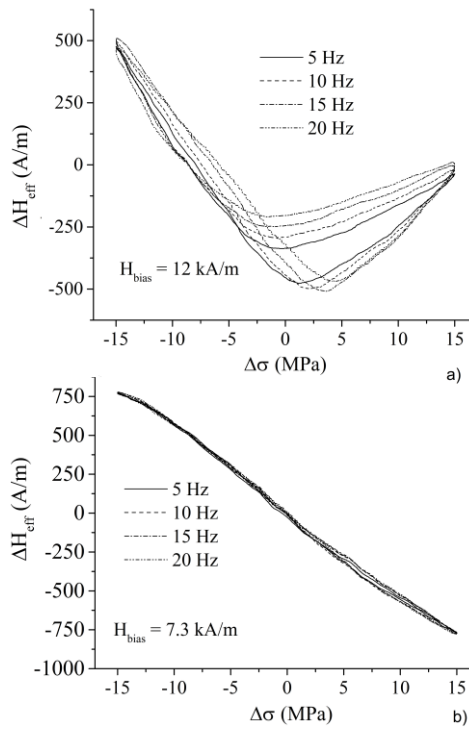

Fig. 5. Cycles  $\Delta H_{\text{eff}}-\Delta\sigma$  at four different frequencies and two different field bias values: a)  $H_{\text{bias}} = 12$  kA/m, b)  $H_{\text{bias}} = 7.3$  kA/m.

high, the stress-induced anisotropy can even overcome the magnetocrystalline anisotropy and the magnetization tends to lie in the plane normal to the rod axis. Consequently, the magnetization process increasingly occurs by moment rotation under increasing value of  $\sigma_{\text{bias}}$  in the lower induction range (e.g. up to about 0.5 T for  $\sigma_{\text{bias}} = -80$  MPa, see Fig. 3).

Further increase of  $H$  promotes the magnetization switching by  $90^\circ$  domain wall processes towards easy crystallographic axes closer to the field direction, as signaled by the corresponding dramatic increase of the permeability. The whole magnetoelastic energy content, estimated by integration of the anhysteretic curve, turns out to be of the order of 17 kJ/m<sup>3</sup>. It is then realized in Fig. 4 that, for a defined  $H_{\text{bias}}$  value, we can, exploiting the near-anhysteretic behavior of the magnetization curves, identify a point corresponding to  $\sigma_{\text{bias}} = -45$  MPa around which a large permeability swing can be obtained under an alternating dynamic stress  $\Delta\sigma_{\text{max}} = \pm 15$  MPa. The oscillating permeability reflects a change of reluctance of the central limb of the magnetizer, which is supplied under a constant current regime, and, consequently, in a field variation  $\Delta H_{\text{eff}}$ . Looking then at the family of magnetization curves surrounding the intermediate curve associated with  $\sigma_{\text{bias}} = -45$  MPa curve (Fig. 3 and inset of Fig. 4), it is understood that the quasi-linear  $\Delta H_{\text{eff}}$  vs  $\Delta\sigma$  behavior observed for intermediate  $H_{\text{bias}}$  values (e.g.  $H_{\text{bias}} \sim 7.5$  kA/m) descends from the corresponding quasi-symmetrical variation of the permeability  $\mu = B(H_{\text{bias}})/H_{\text{bias}}$  of the curves spanning an appropriate  $\Delta\sigma$  interval (for example  $\Delta\sigma \sim \pm 15$  MPa).

Fig. 4 is obtained with  $\Delta\sigma$  pulsating at 20 Hz. Similar families of  $(\Delta H_{\text{eff}}-\Delta\sigma)$  curves are obtained at different frequencies. Fig. 5 shows that, whatever the frequency, the

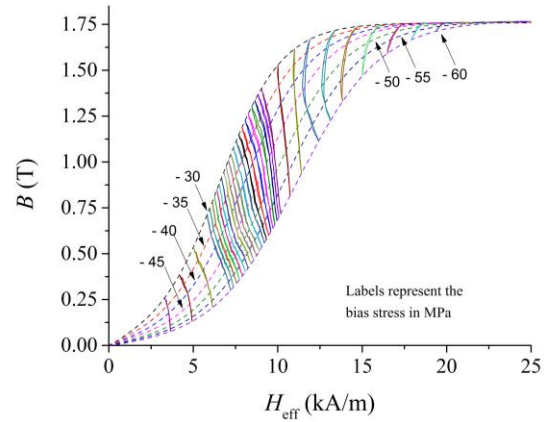

Fig. 6. The  $\Delta H_{\text{eff}}-\Delta\sigma$  curves obtained for compressive bias  $\sigma_{\text{bias}} = -45$  MPa modulated at  $f = 5$  Hz according to  $\Delta\sigma_{\text{max}} = \pm 15$  MPa (Fig. 4) are represented as  $B(H_{\text{eff}})$  curves traversing the family of anhysteretic magnetization curves taken in the range  $-60 \text{ MPa} \leq \sigma_0 \leq -30 \text{ MPa}$ .

system provides quasi-linear hysteresis-free ( $\Delta H_{\text{eff}}-\Delta\sigma$ ) response for  $H_{\text{bias}} = 7.3$  kA/m. The hysteretic frequency dependent behavior of the  $(\Delta H_{\text{eff}}-\Delta\sigma)$  curves obtained with the higher  $H_{\text{bias}} = 12$  kA/m is shown in the same figure.

### B. $\Delta\sigma$ -induced trajectories in the $(B, H_{\text{eff}})$ plane

The  $\Delta H_{\text{eff}}$  curves shown in Fig. 4 as a function of the modulating sinusoidal stress  $\Delta\sigma$  for a sequence of bias field values  $H_{\text{bias}}$  can find a representation in the  $B-H_{\text{eff}}$  plane. For a generic  $j$ -th  $(\Delta H_{\text{eff}} - \Delta\sigma)$  curve (see Figs 4 and 5) the mechanical bias  $\sigma_{\text{bias}(j)}$  and the frequency  $f_j$  are constant and  $n$  sampling points are taken. Each point  $i$  is associated with the quantities  $(\Delta H_{\text{eff}(i)}; \Delta\sigma_i)$ . The total stress and field values are thus given by

$$H_{\text{eff}(i)} = H_{\text{bias}(j)} + \Delta H_{\text{eff}(i)} \quad \forall i=1, \dots, n \quad (1)$$

$$\sigma_i = \sigma_{\text{bias}(j)} + \Delta\sigma_i \quad \forall i=1, \dots, n \quad (2)$$

and the  $j$ -th  $(\Delta H_{\text{eff}} - \Delta\sigma)$  curve is described in the  $(H_{\text{eff}} - \sigma)$  plane by the curve

$$H_{\text{eff}(i)} = \Phi(\sigma_i) \Big|_{\sigma_{\text{bias}(j), f_j}} \quad \forall i=1, \dots, n. \quad (3)$$

obtained at constant bias and constant frequency. This family of curves, represented by (3), have been handled with hysteresis. They define trajectories on the  $(B, H_{\text{eff}})$  plane. These trajectories can be reconstructed taking advantage from the sequence of thirty  $B-H$  magnetization cycles measured under constant  $\sigma_{\text{bias}}$  values, one part of them shown in Fig. 3. To avoid managing a double hysteresis, and considering their extremely narrow shape, the  $B-H$  cycles have been replaced by the related anhysteretic curves. They are described as

$$B_{\sigma_{\text{bias}(k)}} = \Psi_k(H_{\text{eff}}, \sigma_{\text{bias}(k)}) \quad \forall k=1, \dots, 30, \quad (4)$$

where  $\Psi_k$  is a non-linear function of  $H_{\text{eff}}, \sigma_{\text{bias}(k)}$ .

For each pair  $(H_{\text{eff}, \alpha}, \sigma_\alpha)$  given by (3) one can compute  $B_{\sigma_\alpha}$  by entering the corresponding  $\Psi_\alpha$  (4) with  $H_{\text{eff}, \alpha}$  at the same stress  $\sigma_\alpha$ . With this process, it is possible to transpose the  $\Delta H_{\text{eff}}-\Delta\sigma$  curves, like those shown in Fig. 4, into  $B(H_{\text{eff}})$  curves traversing the family of anhysteretic curves under the action of the modulating stress (Fig. 6). A few analyses of force sensors

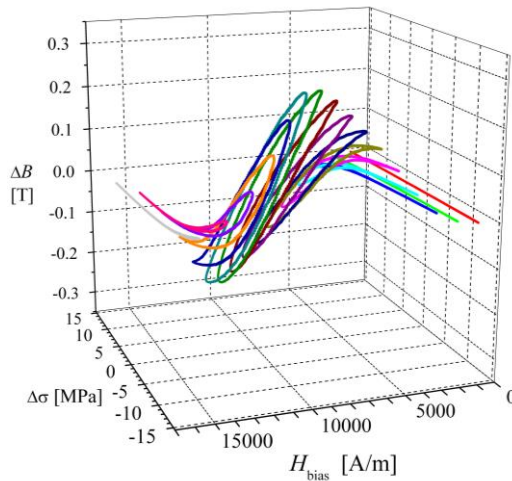

Fig. 7. Measured magnetic flux density variation versus dynamic stress  $\Delta\sigma$  at 20 Hz for different values of the applied field bias  $H_{\text{bias}}$ . Pre-stress  $\sigma_0 = -45$  MPa, dynamic stress amplitude  $\Delta\sigma_{\text{max}} = \pm 15$  MPa.

based on the  $\Delta B$ - $\Delta\sigma$  response of Galfenol have been discussed in the literature [12-15]. However, the  $\Delta B$ - $\Delta\sigma$  curves exhibit substantial hysteresis, as shown in Fig. 7. Forcing their linearization for sensing purposes would result in significant modulus and phase errors in the measurement of force [15].

#### IV. FORCE SENSING

Once the quasi-linear characteristics have been obtained, a significant bias field must be identified for evaluating the stress sensitivity of the Galfenol rod. To this end, an optimization function, to be minimized, is defined in the following. At constant preload, for each magnetic bias value  $\gamma$ , the  $\Delta H_{\text{eff}}$ - $\Delta\sigma$  curve has been interpolated linearly and the following parameters have been evaluated: i) the variance of the data  $s_\gamma^2$ , ii) the area of the hysteresis loop  $A_{h_\gamma}$  and iii) the inverse of the variation of  $H$  ( $1/\Delta H_\gamma$ ). For all the considered frequencies (from 5 Hz to 20 Hz), a sum of these parameters, taken with equal weight, has been minimized

$$\gamma^* \rightarrow \text{Min} \left[ \frac{1}{3} \cdot s_\gamma^2 + \frac{1}{3} \cdot A_{h_\gamma} + \frac{1}{3} \cdot \frac{1}{\Delta H_\gamma} \right] \quad (5)$$

and optimal  $H_{\text{bias}}$  values have been obtained, according to the ranking reported in Table I. Here the values recurrent at all frequencies are highlighted in bold. They are in the range  $7.2 \text{ kA/m} \leq H_{\text{bias}} \leq 7.5 \text{ kA/m}$ . For  $H_{\text{bias}} = 7.3 \text{ kA/m}$  the sensitivity of the specimen defined as  $\xi = |\Delta\sigma_{\text{max}} / \Delta H_{\text{max}}|$  was computed and found to be negligibly affected by the frequency ( $\xi = 2.19 \text{ N/(A/m)}$  at 5 Hz and  $\xi = 2.18 \text{ N/(A/m)}$  at 20 Hz, which is  $0.02 \text{ MPa/(A/m)}$ ). The measured  $\Delta H \sim 1.5 \text{ kA/m}$  (Fig. 5b) is measured on the  $23.9 \text{ kA/m}$  range of the Hall gaussmeter, which provides an analog span of  $\pm 3\text{V}$ . The corresponding resolution is  $0.366 \text{ mV}$ , that is,  $2.92 \text{ A/m}$ . Consequently, the force/stress resolutions are  $6.4 \text{ N}$  and  $0.06 \text{ MPa}$ , respectively.

#### V. CONCLUSION

Low-level dynamic stresses have been measured using a Galfenol rod sample under compressive bias stress. The instantaneous dynamic stress, imposed as a modulation of the

TABLE I  
OPTIMIZED MAGNETIC FIELD BIAS VALUES

N	5 Hz (kA/m)	10 Hz (kA/m)	15 Hz (kA/m)	20 Hz (kA/m)
1	7.9	<b>7.2</b>	<b>7.5</b>	8.1
2	7.6	7.0	<b>7.2</b>	8.2
3	<b>7.3</b>	7.9	7.8	7.9
4	<b>7.2</b>	6.8	<b>7.3</b>	8.4
5	7.8	7.6	8.1	<b>7.5</b>
6	<b>7.5</b>	<b>7.5</b>	6.8	<b>7.3</b>
7	8.1	<b>7.3</b>	6.7	6.8
8	8.2	8.2	6.5	<b>7.2</b>

Ranking of the best  $H_{\text{bias}}$  values according to (5).

bias, shows a linear dependence on the effective magnetic field variation measured at the sample surface with  $H_{\text{bias}}$  in the range between  $7.2 \text{ kA/m}$  and  $7.5 \text{ kA/m}$ , at all the investigated frequencies (5 Hz – 20 Hz). With dynamic stress amplitude  $\Delta\sigma_{\text{max}} = \pm 15 \text{ MPa}$ , force and stress resolutions of  $6.4 \text{ N}$  and  $0.06 \text{ MPa}$ , respectively are obtained.

This paper is a successful preliminary study for the realization of a small force/stress sensor, with larger frequency bandwidth. Modeling approaches must be tuned to perform a suitable design and optimization of the device.

#### REFERENCES

- [1] Y. Tan, Z. Zhang, J. Zu, "Generalized Dynamic Modeling of Iron-Gallium Alloy (Galfenol) for Transducers", Journal of Applied Mathematics and Physics, v. 3, 980-988, 2015
- [2] Y.Y. Lo S.U. Jen and L.W. Pai, "Temperature dependence of mechanical properties of the  $\text{Fe}_{81}\text{Ga}_{19}$  (Galfenol) alloy", Journal of Physics D: Applied Physics, 49 (14), 2016.
- [3] S P Beeby, M J Tudor and N M White, "Energy harvesting vibration sources for microsystems applications", Meas. Sci. Technol., v. 17, R175-R195, 2006
- [4] M. Zucca, A. Hadadian, O. Bottauscio, "Quantities affecting the behavior of vibrational magnetostrictive transducers", IEEE Transactions on Magnetics, v. 51; 8000104-4, 2015, 0018-9464, doi: 10.1109/TMAG.2014.2359248
- [5] S. Sauer, U. Marschner, B. Adolph, B. Clasbrummel, and W-J. Fischer, "Passive Wireless Resonant Galfenol Sensor for Osteosynthesis Plate Bending Measurement", IEEE Sensors Jour., v 12, 5, 1226 – 1233, 2012
- [6] F C Graham, C Mudivarthi, S Datta and A B Flatau, "Modeling of a Galfenol transducer using the bidirectionally coupled magnetoelastic model", Smart Materials and Structures, v. 18, 10, 104013, 2009
- [7] J. Atulasimha, A. Flatau, "A review of magnetostrictive iron-gallium alloys", Smart Materials and Structures, vol. 20, 4, 043001, 2011
- [8] T. Ueno, E. M. Summers, T. Higuchi, "Investigation of magneto-mechanical properties of Galfenol for coil-less magnetic force control using inverse magnetostrictive effect", Proc. Of the Conference: Smart Structures and Materials 2005: Active Materials: Behavior and Mechanics, 5761 p. 200, 2005
- [9] M. Schwartz. Encyclopedia of Smart Materials. Wiley-Interscience Publication, 1st edition, 2002.
- [10] "Guide to the Measurement of Force", The Institute of Measurement and Control, London, Reissued 2013.
- [11] L. Weng, B. Wang, M. J. Dapino, Y. Sun, L. Wang, and B. Cu, "Relationships between magnetization and dynamic stress for Galfenol rod alloy and its application in force sensor," J. Appl. Phys., vol. 113, (2013) 17A917.
- [12] J. J. Scheidler, V. M. Asnani, Z. Deng, M. J. Dapino, "Dynamic characterization of Galfenol", Proc. of SPIE, v. 9432, 94320J, 2015.
- [13] L. Weng, T. Walker, Z. Deng, M. J. Dapino, B. Wang, "Major and minor stress-magnetization loops in textured polycrystalline  $\text{Fe}_{81.6}\text{Ga}_{18.4}$ , Galfenol", Journal of Applied Physics 113, 024508 (2013).
- [14] Q. Zhang, "Experimental characterization of Galfenol (Fe-Ga) alloys", Undergraduate Honor Thesis, Ohio State University, 2014.
- [15] H. Liu, Z. Jia, F. Wang and F. Zong, "Study on the Design Method of Giant Magnetostrictive Force Sensor", Proc. of the IEEE Int. Conf. on Mechatronics and Automation, Aug. 7-10, Beijing, China, 2011.