



ISTITUTO NAZIONALE DI RICERCA METROLOGICA Repository Istituzionale

Traceable 28 m-long metrological bench for accurate and fast calibration of distance measurement devices

This is the author's submitted version of the contribution published as:

Original

Traceable 28 m-long metrological bench for accurate and fast calibration of distance measurement devices / Astrua, Milena; Pisani, Marco; Zucco, Massimo. - In: MEASUREMENT SCIENCE & TECHNOLOGY. - ISSN 0957-0233. - 26:8(2015). [10.1088/0957-0233/26/8/084008]

Availability:

This version is available at: 11696/29367 since: 2021-01-28T15:48:34Z

Publisher:

IOP Publishing [Society Publisher]

Published

DOI:10.1088/0957-0233/26/8/084008

Terms of use:

This article is made available under terms and conditions as specified in the corresponding bibliographic description in the repository

Publisher copyright

Institute of Physics Publishing Ltd (IOP)

IOP Publishing Ltd is not responsible for any errors or omissions in this version of the manuscript or any version derived from it. The Version of Record is available online at DOI indicated above

(Article begins on next page)

Traceable 28 m long metrological bench for accurate and fast calibration of distance measurement devices

Authors: M. Astrua, M. Pisani, M. Zucco

Affiliation: INRiM, Mechanic Division, strada delle Cacce 73 – 10135 – Turin -Italy

Key Words:

Interferometry, Doppler effect, long distance, electronic distance measurement instrument

Abstract

An interferometric bench with 28 m length has been realized at INRiM. The facility is mainly aimed to calibrate electronic distance measurement devices and absolute interferometers. Two working operating modes are possible: a fringe counting mode having an uncertainty of $5 \cdot 10^{-7}$ and a "Doppler" mode having an uncertainty of $3 \cdot 10^{-6}$, the latter allowing high speed movement of the carriage. An accurate motor control allows speed from few micrometers per second up to 2.7 m/s making the device suitable for the calibration of speed measurement devices.

1) Introduction

The dimensional measurement of objects of large dimensions is crucial for many applications. Aerospace, automotive, civil engineering, geodetic monitoring and big science experiments are some examples of the potential interests addressed by the Science and Technology Roadmap for Metrology of EURAMET [1].

At the moment, long distance measurements are performed with electronic distance measurement (EDM) instruments and the problem of their traceability is an open and current issue, furthermore novel absolute interferometers based on different techniques are under development and need metrological verification. To this purpose a couple of EURAMET projects have been activated [2,3].

In this work a new facility developed at INRiM for traceable long distance measurements is presented.

2) Experimental Setup

The facility for long distance measurements is located in a 60 m long corridor of the gallery devoted to dimensional metrology. The structure consists in a 28 m long rail fixed to a series of pillars which rest directly on the basement of the building (13 m below ground level) released from the vibrations of floor and wall. The measuring system is based on a heterodyne interferometer, whose mobile arm consists of a hollow retro-reflector mounted on a structure (we call it "carriage") that can run along the rail.

2.1) Optical design of the interferometer

The length measurement instrument is a heterodyne incremental interferometer (called LORI, LOng Range Interferometer). The main beam of the interferometer with frequency f_1 is generated by a frequency stabilized He-Ne laser (SIOS, model SL 02/2) calibrated with respect to the INRiM length standard and sent to the measurement arm; the second beam is a portion of the first one diffracted by an acousto-optic modulator (AOM) with frequency $f_2 = f_1 + 80$ MHz. The reference detector acquires the beat note signal at 80MHz, while the measurement detector acquires a signal at the same frequency, with a phase difference due to the displacement of the retro-reflector moving on the rail.

The two signals at 80 MHz are filtered by a band-pass filter, are amplified by two low-noise 40 dB amplifiers and then are sent to two different measuring devices:

- 1) In the first the two signals are mixed with a local oscillator at $80 \text{ MHz} + f_{\text{MIX}}$: as a result, all the information on the displacement is contained in the phase between the two signals at the downconverted frequency f_{MIX} (in the present realization from 100 kHz to 1 MHz), which can be more easily acquired and managed from a PC without data loss.
- 2) in the second the two signals are directly acquired by a high resolution frequency counter, in order to obtain the frequency shift due to the carriage movement, which can be converted in speed and integrated over time to obtain the distance covered by the carriage

In figure 1 the optical design of the interferometer is presented.

The first technique is based on fringes counting and so called the “phase measuring” technique: it is extremely accurate, at the level of $5 \cdot 10^{-7}$, therefore it is aimed at the calibration of absolute interferometers and telemeters, but is limited to low carriage speed due to the limited sampling rate of the DAQ device, in the present realization the maximum $f_{MIX} = 1$ MHz corresponds to a maximum carriage speed of 30 cm/s. The second technique, instead, is based on the measurement of the Doppler frequency shift while the carriage runs. This information is used to infer the distance covered by the carriage. This method does not suffer from the carriage speed limit and even if it is less accurate than the classical interferometer, it could be conveniently used for the calibration of commercial EDMs (Electronic Distance Measurement instrument), which generally have a resolution of 0.1 to 1 millimetre, with the advantage of drastically reducing the time needed to cover long distances. The technique also allow to calibrate speed measurement devices up to 10 km/h (2.7 m/s).

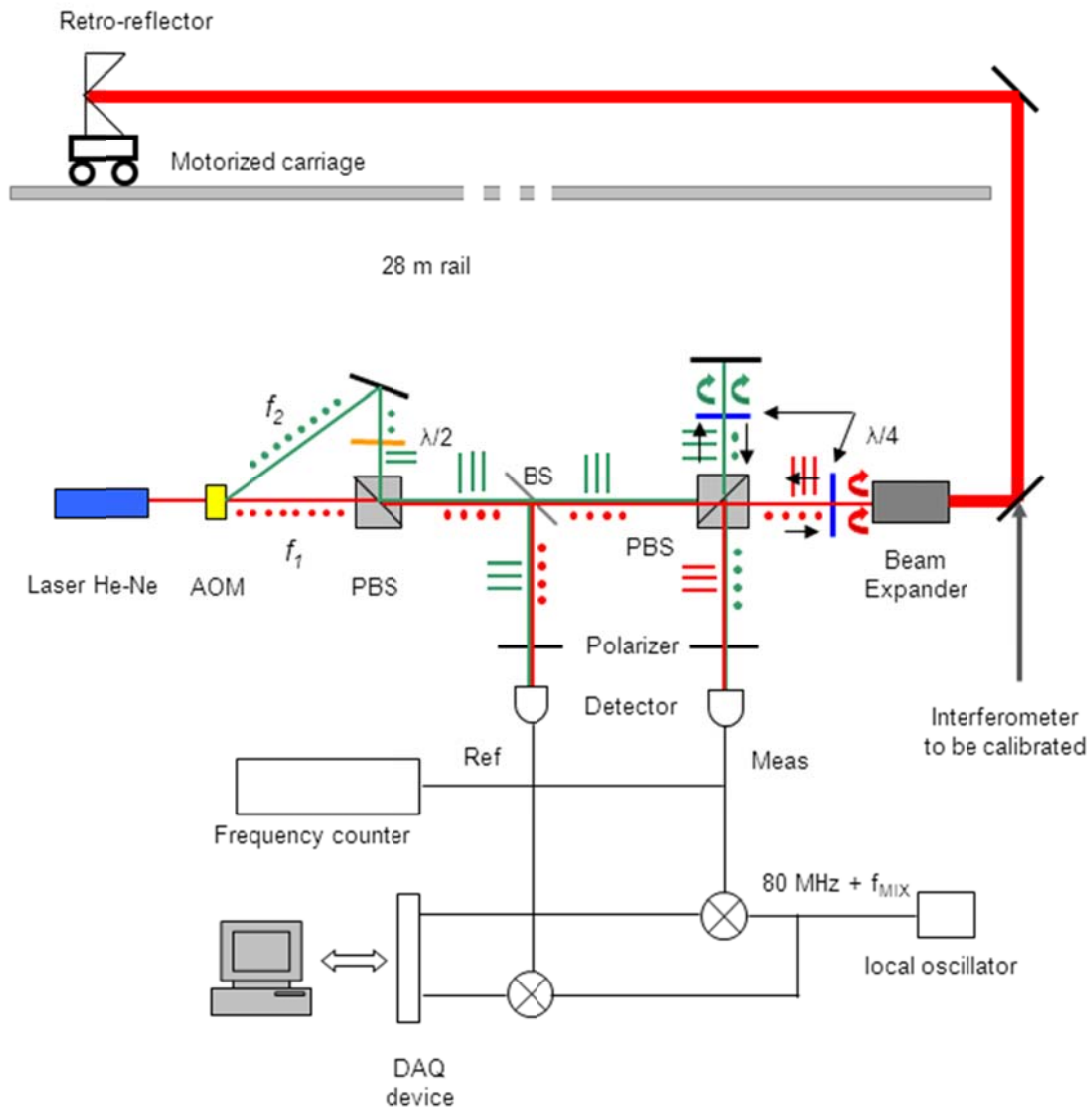

Fig. 1: optical design of the interferometer (AOM = acousto-optic modulator, PBS = polarizing beam splitter, BS = beam splitter, $\lambda/2$ = half lambda plate, $\lambda/4$ = quarter lambda plate)

2.2) Mobile arm of the interferometer

The carriage is moved by a micro-step motor (Orientalmotor, 5-phase stepping motor, CRK Series): the motor driver receives a digital pulse and converts it into an electrical pulse to run the motor. Each pulse causes a rotation of the motor shaft of one step, corresponding to $1/1000$ of a complete revolution of the shaft in the normal mode or $1/250000$ in the high resolution mode. If the pulse frequency increases, the rotation becomes continuous, with a speed that is directly proportional to the pulse frequency. The speed ranges between few $\mu\text{m/s}$ up to 2,7 m/s with a resolution of $0,3 \mu\text{m/s}$.

Since the carriage must move back and forth automatically for a distance of almost 30 m, a remote control to send pulses to the motor driver was implemented. It consists of two parts: a radio command, which allows to set some general parameters of the carriage movement, such as the movement direction and mode of travel (slow with high resolution, or fast with normal resolution), and a fast command, which is performed by an amplitude modulated laser beam placed at the beginning of the track pointing at the carriage. A photodetector placed onboard the carriage receives the modulated laser beam which is transformed into pulses to be sent to the driver of the motor. The modulation of the laser beam is implemented by a LabView® program that controls a digital output of the data acquisition device. The upper part of the carriage hosts two 12 V rechargeable lead batteries to feed the motor and the on board circuits, such as the radio receiver and the photodetector.

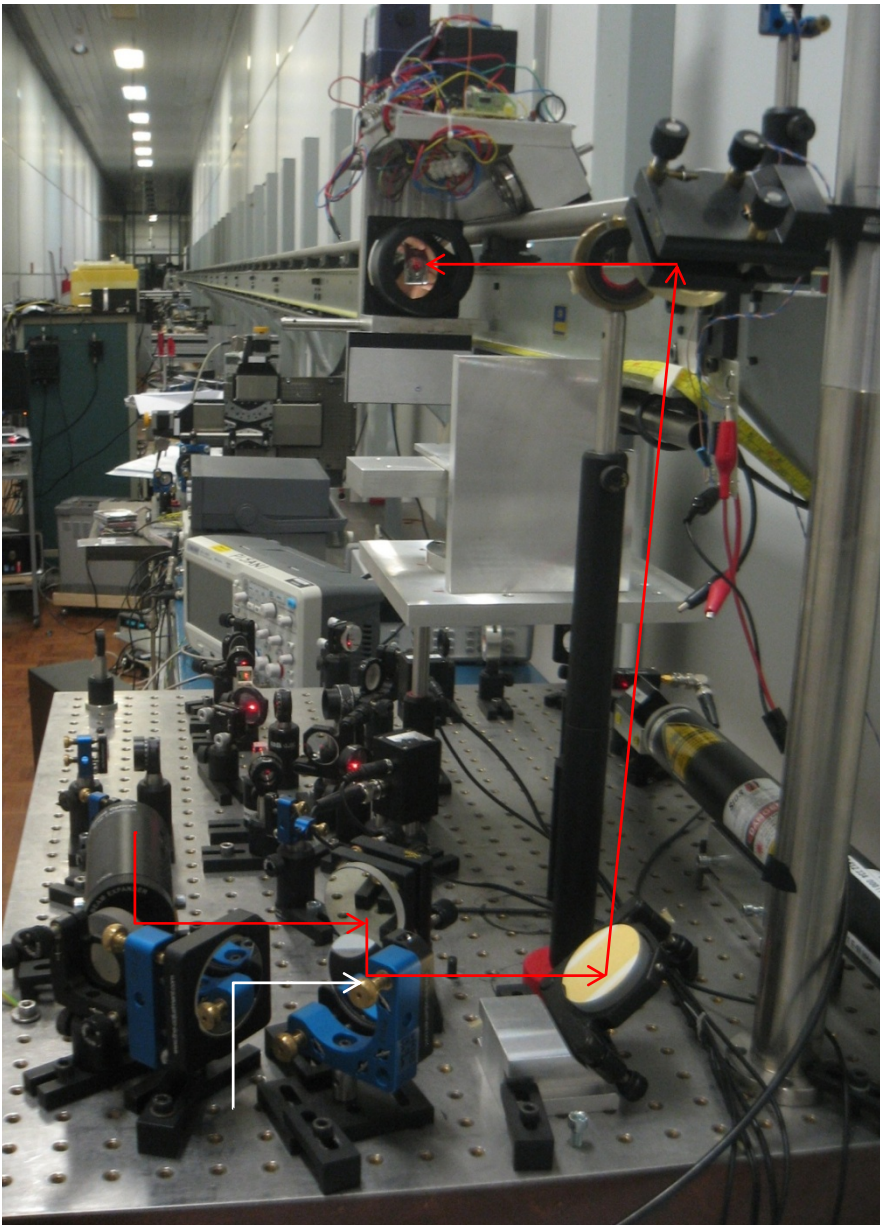

Fig. 2: picture of LORI: in the upper part, the rail and carriage with the retro-reflector are visible; in the lower part, the optical bench of the interferometer is depicted. The red arrows show the path experienced by the laser beam in the moving arm towards the retro-reflector, while the white arrow shows the mirror and the dichroic beam splitter used for the superimposition of other interferometers

Figure 2 clearly shows the carriage at the beginning of the rail, the optical elements of the interferometer on the optical bench and the damped mounting post used as a periscope to deviate upwards the laser beam, since the rail is above the level of the optical bench. The red arrows show the path covered by the laser beam from the beam expander towards the retro-reflector. The white arrow shows the mirror and the beam

dichroic splitter used for the superimposition of other interferometers. It is also visible the platform used for EDMs positioning, in case of calibration of these instruments.

Since originally the rail was not designed to the purpose, it is not perfectly straight along all its length, therefore the carriage movement suffers from horizontal and vertical waving. The peak to peak error of both horizontal and vertical angles (pitch and yaw) is of the order of 300 arcseconds. This has to be taken into account when setting-up a new calibration and when estimating the uncertainty budget, as explained in paragraph 5.2.

The environmental parameters, such as air temperature, atmospheric pressure and humidity, are monitored during the measurement process, in order to calculate the value of air refractive index according to the Edlen's formula [4].

Among these parameters, the temperature distribution along the mobile arm of the interferometer is particularly important, because important longitudinal temperature gradients due to the presence of electronic instruments nearby the optical bench were found. To the purpose, 14 thermometers were uniformly dislocated along the rail and automatically recorded during the measurement process.

3) The fringe counting technique

In this technique the displacement information is contained in the phase between the reference and the measuring signals at 80 MHz. The phase information is preserved in the downconversion to a frequency that can be conditioned and acquired by the acquisition board. The data acquisition board, represented in Figure 1, is the National Instruments NI PCI-6132 with four parallel analog to digital 14 bit conversions with a sampling rate of 2.5 MSamples/s.

Hence with this set-up, the maximum carriage speed is limited to approximately 30 cm/s, which means about 100 s to cover the whole rail.

As introduced in section 2.2 a program implemented in LabView® acquires the two signals from the DAQ device, calculate the displacement of the carriage with an In-phase Quadrature (IQ) demodulation. The core of the program is the algorithm to measure the incremental phase difference and therefore the displacement covered by the carriage according to the following figure.

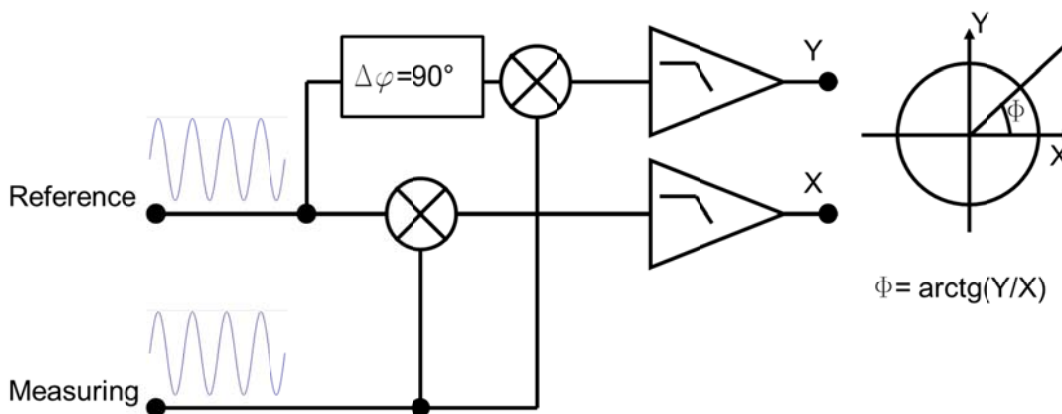

fig 3. The algorithm to measure the incremental phase difference and the displacement covered by the carriage from the signals coming from the interferometer.

In the algorithm the downconverted signal from the reference detector is multiplied by the other signal coming from the measuring detector having phase and frequency varying with the optical path variations. The signal obtained by the product is filtered with a IIR lowpass filter to remove the component due to the sum of the signals, and represents the Y axis of the phase. On the other hand, the reference detector signal is delayed by 90°, by means of a Hilbert transform, then it is multiplied by the signal from the measuring detector: again the product is low-filtered and represents the X axis of the phase. The phase is then calculated by the relation $\phi = \arctg(Y/X)$ and the optical path variation is $\Delta L = \lambda \phi / 2\pi$, where λ is the laser wavelength in air. We have implemented a code to unwrap the phase and solve the limitation of the fact that the arctg is modulo 2π .

3.1) Uncertainty budget

In this section we analyze the uncertainty budget of the fringe counting technique by going through the different contributions. In this analysis we consider only the contribution from the interferometer, the contribution from the index of refraction is calculated in section 4.

1) Laser reproducibility

According to the specification, the SIOS SL02 laser has a relative long term stability of 10^{-8} . Considering a rectangular distribution the standard uncertainty is

$$u(f_L)/f_L = 10^{-8} / \sqrt{3} = 6 \cdot 10^{-9}$$

corresponding to about 4 fm as standard uncertainty of the wavelength in vacuum at 633 nm.

2) Non linearities

There are effects due to non perfect separation of polarized beams in the polarizing beam splitters in the optical part or to cross talk between the measuring and reference arms in the radio frequency part. This can be seen as deformations of the phase circle and causes cyclic errors having periodicity of the wavelength or higher orders [ref]. In our case we have measured this contribution and we give a conservative value to 33 nm corresponding to about one tenth of a fringe.

$$u(NL) = 33 \text{ nm}$$

The fringe counting and unwrapping algorithm has no error and this contribution is zero.

3) Divergence

The beam sent to the measuring arm of the interferometer is expanded to a beam having a Gaussian shape with diameter of about 3 cm. In this case we consider the effect of divergence negligible.

x_i	Standard uncertainty $u(x_i)$	$u_i(l_{ref})$ (um)
λ_0	4 fm	0.0065 L
NL	33 nm	0.033
Div	0	0

The fringe counting technique was validated by means of a comparison with another incremental interferometer (HP model 5526 A) with a resolution of 20 nm and an accuracy of $5 \cdot 10^{-7}$. The laser beam of the HP interferometer was superimposed to the LORI beam along the measuring arm (as it is shown in figure 2 by the white arrow).

The comparison between the two interferometers was done by moving the carriage along the rail at different speed up to 14 mm/s by measuring the displacement of the carriage with the two systems simultaneously. Since the two lasers have the same wavelength and run through roughly the same path, the air index of refraction affects both the interferometers in the same way. Therefore it was possible to perform the comparison simply with the wavelength of the two lasers in vacuum, ignoring the value of the air refractive index. The relative average difference between the two interferometers is of the order of 10^{-8} , an indication that the two systems are in good agreement with each other. Hence the fringe counting technique can be considered validated within the accuracy of the HP interferometer.

4) The “Doppler frequency measurement” technique

According to the well-known Doppler effect, mechanic or electromagnetic waves emitted from a source moving toward an observer are squeezed so that the wavelength is decreased and the frequency is increased. Viceversa for a source moving away from an observer. This effect is widely used, for example in the field of velocimetry for non contact measurements of flow velocity in liquid or in gas, and vibrometry [5]

In our case it is possible to exploit the Doppler effect generated by the carriage movement to infer the covered distance.

When the carriage is still, the detector of the measuring arm picks up the beat note signal between the two laser beams with frequency f_1 and $f_2 = f_1 + 80$ MHz, respectively, so that the beat note frequency will be $f = 80$ MHz.

Now, when the carriage moves away from the beginning of the rail (i.e. from the detector) at speed v , the laser beam with initial frequency f_i that travels to the retroreflector and back to the detector will have a final frequency f_3 shifted due to the Doppler effect $f_3 = f_i (1+v/c)^1$.

Since the speed of the carriage is much smaller than the speed of light, it is possible to expand in series the binomial so that $f_3 = f_i (1+v/c)^1 \approx f_i (1-v/c) = f_i - f_i \cdot v/c = f_i + f_D$

Therefore, in that case, the detector of the measuring arm will pick up the beat note signal between f_3 and f_2 so the beat note frequency will be $f' = 80 \text{ MHz} - f_D$

To have an idea of the order of magnitude, we can make a numeric example. If the speed of the carriage is 300 mm/s, the ratio v/c will be 10^{-9} , so the Doppler frequency will be $f_D = 0.47 \text{ MHz}$, being the frequency of a He-Ne laser $f_i = 470 \text{ THz}$.

Therefore if we are able to accurately measure the Doppler frequency for a certain time interval, we can derive the speed of the carriage, v . As a consequence, the distance covered by the carriage can be deduced by integrating the speed of the carriage for the time interval.

In practice, in our experimental set-up the two beat note signals from the reference and from the measuring detectors are directly acquired by a commercial high-performance frequency counter (a Pendulum CNT-90) without dead time based on time stamping.

The distance covered by the carriage is obtained according to the following formula

$$s = \frac{1}{2} \int (f' - f) \frac{\lambda}{n_{air}} dt = \frac{1}{2n_{air}} (f' - f) \lambda t_i \quad (1)$$

where s is the distance covered by the carriage, f is the frequency of the reference signal, f' the frequency of the measuring signal with the carriage moving, λ is the wavelength of the laser in vacuum, n_{air} is the air refractive index and t_i is the integration time. The difference $f' - f$ is just the Doppler frequency.

In order to evaluate the uncertainty of the distance measured by means of the Doppler technique, the different sources of uncertainty are analysed in the following.

The time interval measurement resolution of the instrument is 100 ps and the time base is connected to the INRIM UTC, so that the measurements of the Doppler frequency and the integration time are extremely accurate and a relative contribution to the uncertainty budget of the order of 10^{-11} can be estimated.

The relative short term stability of the frequency generated by the AOM was evaluated to be of the order of $3 \cdot 10^{-9}$; the same order of magnitude was estimated for the uncertainty of the wavelength of the laser in vacuum.

Hence the component which mostly affects the uncertainty of the distance measured by means of the Doppler technique is essentially due to the environmental parameters, such as air temperature, atmospheric pressure and partial pressure of water, and a relative uncertainty equal to $3 \cdot 10^{-7}$ is estimated.

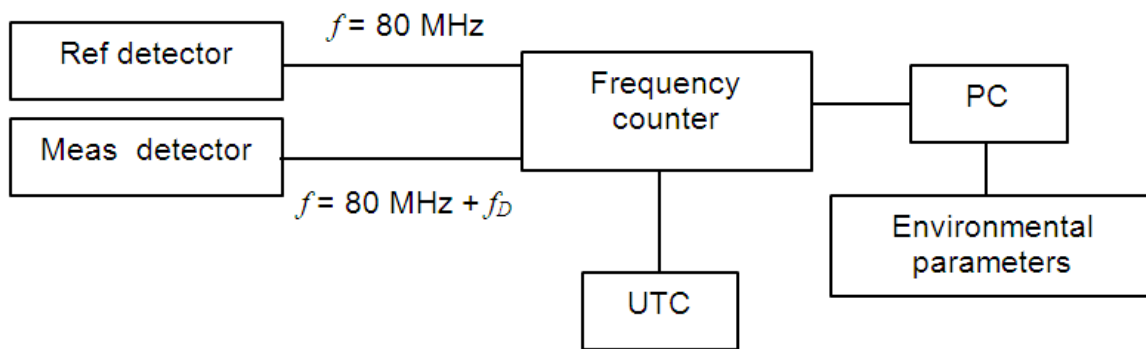

Fig. 4: design of the Doppler measuring technique

The Doppler technique was validated by means of the comparison with the fringe counting technique at low speed with an agreement of the order of $3 \cdot 10^{-6}$.

The agreement is less good than what was expected, probably because of the procedure used for the comparison itself: indeed, the distance obtained by the fringe counting technique was measured continuously without interruptions even in the condition of still carriage, while the same distance measured by the Doppler technique was obtained by an interspersed set of measurements. The uncertainty of the comparison can easily be attributed to the dead times occurring during the measurement combined to the unavoidable mechanical unstability of the mirror position.

In any case, the Doppler frequency method could be considered validated within 0.1 mm over the whole rail path with the advantage of reducing the time needed to cover long distances. Since we use the “Doppler” method instead of the “fringe counting” method when accuracy is not demanding and high measurement speed is required, we decided to assume conservatively the uncertainty obtained in the comparison for practical application.

5) Applications

5.1) calibration of interferometers

This facility has the advantage of being able to calibrate or to validate other distance meters with different wavelengths since the input port in Fig 1 is made of a dichroic plate in order to minimize radiation in the wrong direction. Moreover the retroreflector is a hollow corner cube where the internal faces are metal coated: this permits a high reflectivity in a wide range of wavelengths.

As an example of a calibration of an absolute interferometer we can quote the validation of a distance meter based on a Er doped femto second laser at 1.5 μm . The device is described in [6] and the final measurement showed the final accuracy of the distance meter of few tens of micrometers.

Similarly, we have validated the synthetic wavelength interferometer, described in [7], and developed at INRiM to monitor reciprocal movements of large satellite parts. Also in this case, the final accuracy of few micrometer is limited by the interferometer being measured.

5.2) calibration of EDMs

The “Doppler” technique is aimed at those applications that do not need the highest accuracy level, but rather short measuring times, such as the calibration of commercial EDMs. These instruments are widely used for long distance measurements: their measuring range spans up to hundreds meters with a resolution generally ranging from 0.1 mm to 1 mm. In order to assess our calibration and measurement capabilities in this field, we recently participated to the EURAMET project n. 1169, focused on the comparison of laser distance measuring instruments [8].

The calibration of an EDM is based on the comparison between the distance covered by the carriage and measured by the EDM and the same distance measured by means of the Doppler frequency technique.

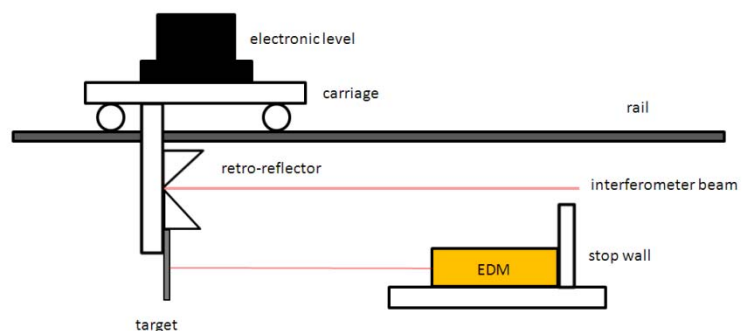
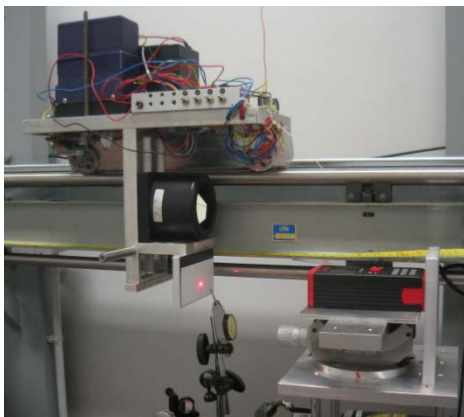

Fig. 5: picture and scheme of the set-up for the calibration of EDMs.

As shown in fig 5, a target for EDM pointing is mounted on the carriage structure, just below the retroreflector so that the EDM laser is as close and parallel as possible to the reference beam.

The EDM to be calibrated is placed on a cradle-like platform, in order to have the possibility to adjust the pitch angle of the instrument. Behind the platform, the EDM leans against a stop-wall that represents the “zero point” for the length measurements.

The position of the calibration points can be decided from time to time, while the first calibration point is set by the geometry of our set-up, indeed, the target is not able to go in contact with the stop-wall, therefore it is not possible to perform the first point of measurement by means of the interferometer. To overcome this problem, an aluminium ruler with nominal length equal to 30 cm is adopted to set the distance between the target plate and the stop-wall for the first point of measurement. A mechanical probe, that touches the

carriage structure when carriage is in the “30 cm” position, is used as a reference measurement to check the repeatability of this distance after each measurement set. Then, the ruler is removed and the EDM to be calibrated is placed on the base and gently pushed against the reference wall. The horizontal and vertical angles are adjusted in order to hit the central point of the target. The first point is recorded here.

Then the carriage is moved in the next position and the EDM measurement is repeated. The operation is repeated for the whole length of the rail, up to 28 m. The measurements are then repeated again back to the first point, so that each point is measured twice. For each positioning the incremental displacement is measured by the interferometer in the Doppler mode.

At the end of the measurement set, when the carriage is at the 30 cm position again, the sum of the interferometric measurements should be very close to zero. The residual value is compared with the difference between the first and the final measurements of the mechanical probe. The difference must be within the uncertainty of the Doppler technique, otherwise some error occurred in the measurement set that must be repeated.

Taking advantage of the high speed of the carriage allowed by the Doppler technique, it is possible to perform a complete measurement run up to 28 m and back in about 30 minutes.

An uncertainty budget for the calibration of an EDM was build taking into account the following uncertainty components:

- 1) the uncertainty related to the measurement of the first 30 cm performed using the ruler
- 2) the uncertainty due to the unavoidable errors of geometrical misalignment of the set-up, such as the errors in the parallelism between the stop-wall and the target or between the two beams, and the errors in the orthogonality between the target and the rail
- 3) the uncertainty due to the rail straightness error
- 4) the uncertainty on the environmental parameters
- 5) validation of the Doppler method by comparison with the fringe counting technique
- 6) EDM repeatability

The components which mostly affect the overall uncertainty come from the set-up geometry (in particular from the parallelism between the stop-wall and the target) and from the validation of the Doppler method, even if that component is probably conservative as explained in the previous paragraph.

Concerning the component 3), in this alignment configuration the horizontal waving does not affect the measured length, since the EDM is placed just below the interferometer laser beam. Otherwise, the length measured by the EDM is highly affected by the carriage vertical waving, but this angle can be monitored by means of an electronic level placed above the carriage, as shown in fig 5.

The last component represents the repeatability of the EDM measurements and is estimated equal to the resolution of one of the best EDM available, such as the Mekometer Kern ME5000, i.e. 10 μ m, or other absolute distance interferometer, high quality total stations and laser trackers, although the resolution and the accuracy of commercially available EDM are worse than this.

In the following table the values of the uncertainty component are reported.

<i>N</i>	<i>Description</i>	<i>Standard uncertainty</i> $u_{\lambda}(l) / mm$
1	Uncertainty of the ruler length and reproducibility of the ruler measurement	0.015
2	the uncertainty due to geometrical misalignment errors	0.029
3	uncertainty due to the rail straightness error	0.0014
4	uncertainty on the environmental parameters	$3 \cdot 10^{-4} \cdot L$
5	validation of the Doppler method	$3 \cdot 10^{-3} \cdot L$
6	EDM repeatability	0.010

According to this uncertainty budget, an expanded uncertainty equal to $U=Q[0.07, 0.006 L/m]$ mm has been derived and is now included in the BIPM database [9].

6) Conclusions

A new facility developed at INRiM for traceable long distance measurements is presented. It is based on a heterodyne incremental interferometer, whose moving arm is represented by a corner cube mounted on a carriage moving on a rail 28 m long under the control of microstep motors allowing a speed range from few $\mu\text{m/s}$ up to 2.7 m/s.

The distance covered by the carriage is traceable to the length standard by means of a classical heterodyne interferometer through the “phase measurement” technique. It was validated by means of a comparison with another incremental interferometer, at a level of relative uncertainty of $5 \cdot 10^{-7}$ and aim at the validation of absolute interferometers and telemeters. The interferometer or telemeter under control is superimposed to the reference interferometer via a dichroic beam splitter so that the two optical path coincide reducing to zero the Abbe error. A limit of this interferometer is that it is able to count the fringes only for carriage speed up to 30 cm/s. For higher carriage speed another measurement system able to measure long distance is implemented: the Doppler frequency shift of the laser when the carriage is moving is measured, then it is converted in speed and the speed is integrated over time to obtain the distance covered by the carriage. The “Doppler frequency measurement” technique was compared at low speed with the “phase measurement” technique with a relative agreement of $3 \cdot 10^{-6}$ with the advantage of reducing the time needed to cover long distances, so even if this method is less accurate than the interferometer it could be conveniently used for the calibration of commercial electronic distance meters (EDM). Finally the facility can be used to calibrate speed measurement instrument like “laser barriers” or Doppler or time of flight “laser gun” up to 10 km/h.

Acknowledgements

Authors would like to acknowledge Marco Santiano and Emanuele Audrito for their support in the mechanical realization and Gaetano La Piana for the realization of the remote radio control.

References

- [1] http://www.euramet.org/fileadmin/docs/Publications/roadmaps/EURAMET_Science_and_Technology_Roadmaps_for_Metrology.pdf
- [2] EMRP SIB60 “Surveying” of the European Metrology Research Programme (EMRP) www.ptb.de/emrp/surveying.html
- [3] EMRP IND53 Large volume metrology in industry (LUMINAR = Large volume Unified Metrology for Industry, Novel Applications and Research) <http://projects.npl.co.uk/luminar/>
- [4] Birch K P and Downs M J 1994 “Correction to the updated Edlén equation for the refractive index of air” *Metrologia* **31** 315–316
- [5] L.E. Drain The laser Doppler technique J. Wiley and Sons: Chichester, 1980
- [6] A Pesatori, M Norgia, C Svelto, M Zucco, M Stupka, A De Marchi, *High-resolution mode-locked laser rangefinder with harmonic downconversion*, Instrumentation and Measurement, IEEE Transactions on 61 (5), 1536-1542
- [7] M Zucco, M Pisani, M Astrua, *A two-wavelength interferometer for space applications*, Precision Electromagnetic Measurements (CPEM 2014), 2014 Conference on, 242-243
- [8] M. Wisniewski, et al. Final report on supplementary comparison EURAMET.L-S20: Comparison of laser distance measuring instruments 2014 *Metrologia* **51** 04002
- [9] <http://kcdb.bipm.org/AppendixC/default.asp>