



ISTITUTO NAZIONALE DI RICERCA METROLOGICA Repository Istituzionale

Loss analysis of an asynchronous multiphase motor-generator for avionics applications

This is the author's submitted version of the contribution published as:

Original

Loss analysis of an asynchronous multiphase motor-generator for avionics applications / Bottauscio, O.; Chiampi, M.; Zucca, M.; Serra, G.. - In: INTERNATIONAL JOURNAL OF APPLIED ELECTROMAGNETICS AND MECHANICS. - ISSN 1383-5416. - (2015). [10.3233/JAE-151998]

Availability:

This version is available at: 11696/28974 since: 2020-10-26T15:16:44Z

Publisher:

IOS Press

Published

DOI:10.3233/JAE-151998

Terms of use:

This article is made available under terms and conditions as specified in the corresponding bibliographic description in the repository

Publisher copyright

(Article begins on next page)

Loss Analysis of an Asynchronous Multiphase Motorgenerator for Avionics Applications

Oriano Bottauscio^a, Mario Chiampi^b, Mauro Zucca^{a*}, Giovanni Serra^c

^a*Electromagnetic Division, Istituto Nazionale di Ricerca Metrologica (INRIM), Strada delle Cacce 91, Torino (Italy)*

^b*Dipartimento Energia, Politecnico di Torino, Corso Duca degli Abruzzi 24, Torino (Italy)*

^c*Dip. Ing. dell'Energia Elettrica e dell'Informazione, Università di Bologna, Bologna, (Italy)*

Abstract. This paper aims at analyzing electric motor-generators specifically designed for the avionic application in More Electric Aircraft, where the machine is included inside the main gas turbine. Because of the harsh environment (high temperatures), the problem of evaluating and reducing the losses produced in these machines becomes crucial. For such a purpose, this paper presents an accurate estimate of the magnetic and Joule losses produced inside the machine, when operating as generator in a range of frequencies from 200 Hz up to 400 Hz. Particular attention is paid to the investigation of the effects introduced by the use of a high number (6 and 12) of phases, due to fault tolerance reasons. The analysis is developed on a small (10 kW) prototype, consisting of a four-pole twelve-phase induction machine. The numerical computations are performed through a validated 2-D finite element code, based on a step-by-step procedure and on the sliding mesh technique. A sophisticated laminated dynamic Preisach model, whose parameters are identified from a large set of measurements, provides an accurate estimate of the iron losses and their separation into the three fundamental components also under skin effect regime. The results show that six and twelve phase configurations produce significant loss decrease. A preliminary investigation about the machine losses, when working under fault conditions, is finally presented.

Keywords: Electromagnetic modeling, Fault tolerant systems, Induction machines, Magnetic losses.

1. Introduction

The introduction of more electric devices in the avionics, in particular for operating servomechanisms or mechanical parts, has considerably accelerated in recent years. The increase of electrical equipments on aircrafts, and the associated rise of the installed electric power, goes under the name of "More Electric Aircraft" (MEA). In such a framework, this paper focuses on the analysis of a multiphase machine for the "More electric engine" [1,2]. The latter is the research on new generators to be installed directly on the turbofan shaft and acting also as a starter motor. For the characteristics of the environment, subject to high temperatures and low thermal exchange, the motor-generator needs to have low losses and a high tolerance to faults. Despite the advantages of PM machines [3], induction machines are preferred when mounted directly on the turbofan shaft, due to the degraded performance of permanent magnets at high temperature. In addition, induction machines allows one both regulating (work at constant power) or excluding the excitation in case of fault [4]. In this context, the authors have proposed a twelve-phase induction machine, demonstrating how a Fe-Co rotor could provide some benefits in terms of loss reduction [4]. The choice of a multiphase machine has more than one advantage, as the need of low rating power switching devices, the possibility of tuning the torque density and the improvement of the fault tolerance [5,6].

This paper aims at comparing, in terms of iron and Joule losses, three functioning conditions where the machine windings are supplied in three-phase (for reference), six-phase and twelve-phase configurations. The analysis is carried out using a FEM code extensively validated [7], investigating the machine behaviour as generator for different supply frequencies at a fixed 1% slip.

*Corresponding author. Tel./Fax: +39 011 3919827; E-mail: m.zucca@inrim.it

The trend of losses is also analyzed for the six-phase and the twelve-phase configurations, when one of the inverters is supposed not to provide the supply voltage at the terminals (open circuit) as a consequence of an internal fault. The results show that the increase of the phase number reduces both the iron and total losses. It is finally found that a fault on an inverter leg does not produce a significant variation of iron losses; the dramatic increase of the Joule losses is anyway limited in the twelve-phase configuration.

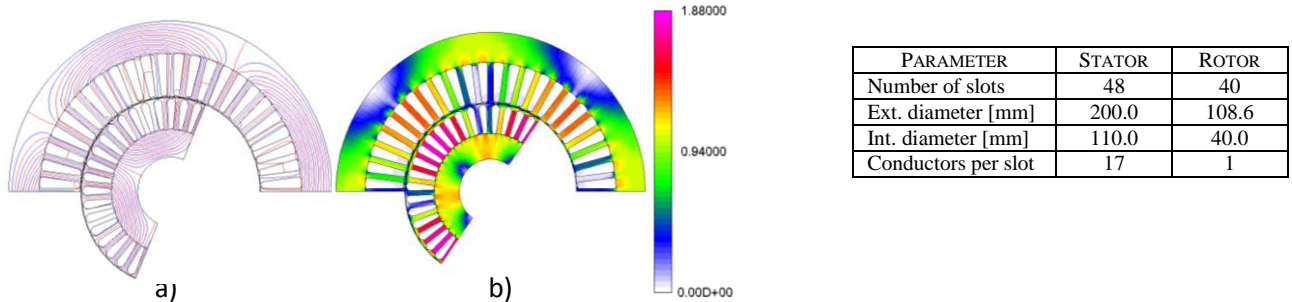

Fig. 1. Generator layout under twelve-phase operating conditions at 200 Hz: instantaneous magnetic flux (a) and magnetic flux density amplitude (b) distributions. The table presents the machine parameters

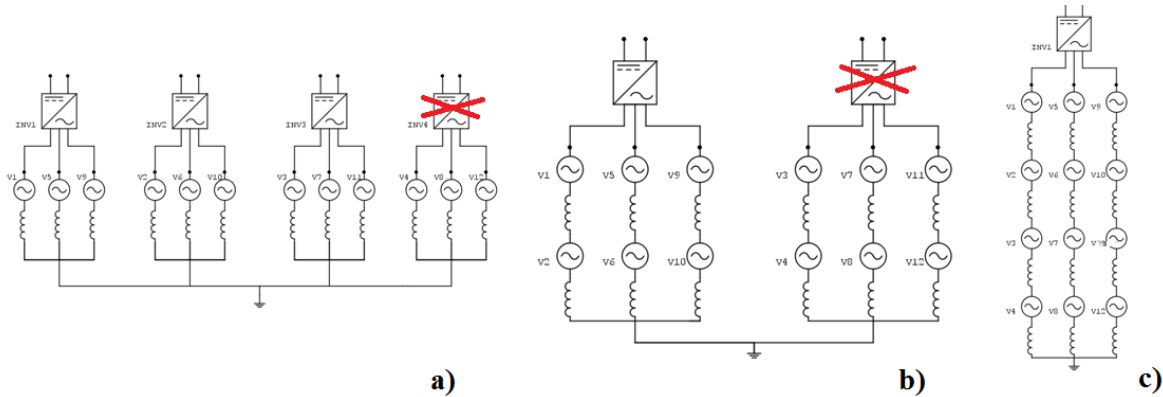

Fig. 2. Machine winding configurations: a) twelve-phase, b) six-phase and c) three-phase. A red cross highlights the two fault conditions under analysis.

2. Device and modeling approach

The analysis is performed on a 10 kW rated power, four poles small prototype, whose magnetic core (stator and rotor) is constituted by 0.2 mm thick non-oriented Fe-Si laminations. The geometry and the main parameters are summarized in Fig. 1, where the instantaneous magnetic flux and magnetic flux density distributions are also shown for the twelve-phase generator at 200 Hz. Since the machine works in a wide speed range, the study is developed at 6000 rpm (200 Hz), 9000 rpm (300 Hz), and 12000 rpm (400 Hz).

The stator windings are divided into twelve sub-sections, allowing the supply by three, six or twelve phase systems, simply by the change of the connections and the number of supply inverters (see Fig. 2). The supply voltage of a single sub-section is increased linearly with the frequency up to 270 Hz (~143V) and then kept constant at higher frequencies, determining magnetic flux weakening. The comparison is performed by imposing to each winding subsection the voltage amplitude according to the drive characteristics. The fault conditions are simulated by removing the whole leg of one power inverter in six-phase and twelve-phase configurations.

The computations are carried out through a validated finite element code, which implements a 2-D time-domain field formulation in terms of magnetic vector potential. The fixed point technique suitably handles the magnetic nonlinearities (i.e [7-9]). The interaction between field and circuits is accounted for by a voltage-driven approach, which adds the circuit equations and set the stator and rotor currents as problem unknowns. The sliding mesh technique along an interface in the air-gap region enables the rotor motion without requiring the entire domain remeshing. Details about the model can be found in [8]. The finite element simulations are developed including the magnetic saturation, but disregarding hysteresis, having proved that this simplifying assumption does not affect the result accuracy [8].

The magnetic losses are estimated a-posteriori from the computed time-spatial distribution of the magnetic flux density, by using the laminated-Preisach model, which accounts for skin effect in lamination depth and dynamic hysteresis [10]. The model parameters are identified, starting from 1-D and 2-D characterizations of the electric steels in the frequency range up to 10 kHz, according to the procedure proposed in [11]. The accuracy of the dynamic loop reconstruction is discussed in [4].

3. Analysis of the influence on losses of the phase number

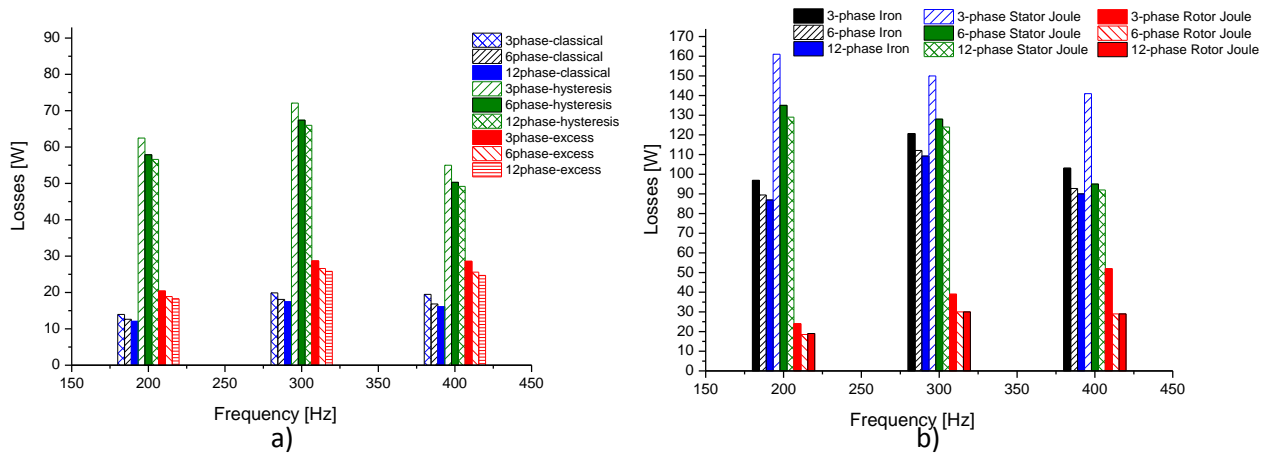

Fig. 3. Computed losses for the three configurations. a) Iron losses separated into classical, hysteresis and excess losses; b) Total losses include iron, stator Joule and rotor Joule losses

The analysis of the machine behaviour has been performed through the FEM approach described in Sect. 2, adopting for the three configurations the same mesh which includes $\sim 2 \cdot 10^4$ triangular elements with $\sim 10^4$ nodal unknowns (vector potential). The phase number is imposed through suitable connections between the sub-windings described in the circuit equations. Fixed rotational speeds are assumed in the rotor to ensure a 1% slip (generator) for all the considered frequencies. The time evolution is represented using 8000 time samples for a total duration of 165 ms, more than sufficient to guarantee the completion of all the electric transient phenomena.

In a first investigation the three, six and twelve-phase generators are compared when operating under rated conditions at 200 Hz, 300 Hz and 400 Hz. The results show how the phase number does not affect in a visible way neither the flux distribution in the rotor and stator core, nor the flux density amplitude reached inside the machine. The iron losses and their separation are presented in the diagram of Fig 3a, where colors blue, green and red denote three, six and twelve phase generators, respectively. In general, all the contributions increase moving from 200 Hz to 300 Hz, but reduce at higher frequency, because of the magnetic flux weakening. All the loss terms decrease of some percent when increasing the phase number and such a reduction is more pronounced for the classical losses ($\sim 10\%$ in 6-phase and $\sim 15\%$ in 12-phase with respect to the 3-phase). On the contrary, the spatial distribution of the losses (stator yoke 34%, stator teeth 45-48%, rotor teeth 12-15%, yoke 6%) and their separation (Classical 14-18%, Static 65-54%, Excess 21-28% going from 200 Hz to 400 Hz) are similar in all the configurations. The Joule losses, presented in Fig. 3b, show a general decrease at the frequency increase. In this case, a more significant advantage is given by the higher number of phases: the reduction with respect to the three-phase configuration always overcomes 20% and can reach 35% in the case of stator Joule losses at 400 Hz.

Fault conditions are modelled by disconnecting the electric network supplied by one of the inverters in the 6 and 12-phase configurations, i.e. imposing a null current to the corresponding windings. Some variations appear in the magnetic flux distribution inside the machine and they are more evident in the diagram of the normal component of the magnetic flux density along the airgap (Fig. 4 a and b). The presence of slots without currents, clearly understandable mainly in the six-phase machine, makes the spatial envelope of the magnetic flux density much different from the sinusoidal shape than in the health case. An influence can also be found in the supply currents of the legs of the twelve-phase machine not

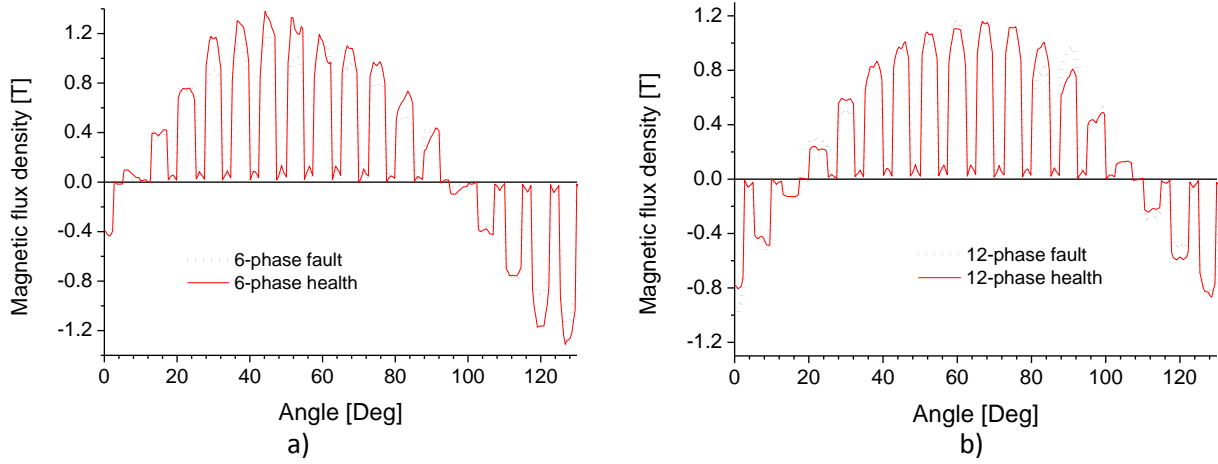

Fig. 4. Normal component of the magnetic flux density in the airgap under rated and fault operating conditions for six-phase (a) and twelve-phase (b) generator.

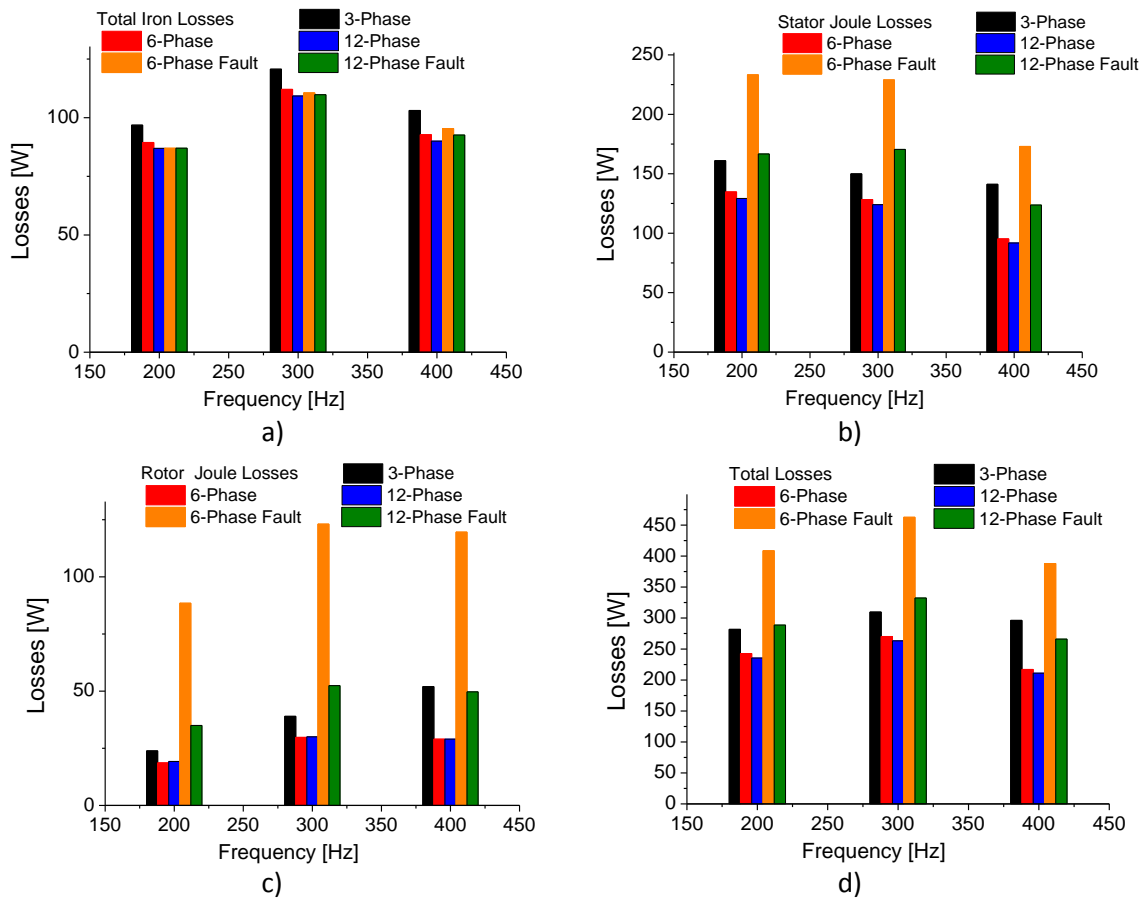

Fig. 5. Loss comparison between the behavior under rated and fault operating conditions for six-phase and twelve-phase configurations (the results for three-phase configuration are presented as a reference): a) iron losses, b) Joule stator losses, c) Joule rotor losses, d) total losses.

affected by the fault; while for the generator in healthy conditions the four currents have the same amplitude with an angular shift of 15° , under fault conditions the three currents show amplitude differences of some percent. The fault engenders slight variations on the iron losses, but the effects on Joule losses are dramatic, as shown in Fig 5.

The fault always significantly increases the copper losses, mainly, as expected, in the six-phase configuration where one half of the machine (against a quarter in the 12-phase configuration) is not supplied. This effect is enhanced in the rotor cage where the spatial flux density distribution is far from the ideal sinusoidal shape and produces higher induced phenomena. Thus, under fault conditions the six-phase generator shows a Joule loss increase up 80% in the stator and up to 375% in the rotor.

Conclusions

In this paper a FEM analysis of losses in an electric generator specific for MEA application is developed, comparing three, six and twelve phase configurations. The results show that the twelve-phase machine is the most advantageous solution reducing both iron losses in the magnetic core and the Joule losses in the stator windings and in the rotor cage. The twelve-phase generator is found to be more convenient also when operating under degraded fault condition, significantly limiting the Joule loss increase with respect to the six phase configuration. Thus, the twelve-phase machine, in itself attractive for the high degree of fault tolerance, it is also interesting for the lower contribution to losses both in health and in fault conditions.

References

- [1] Hirst M.; McLoughlin A.; Norman P.J.; Galloway S.J., "Demonstrating the more electric engine: a step towards the power optimised aircraft", IET-Electr. Power Appl., vol. 5, no. 1, (2011), pp. 3-13.
- [2] Boglietti, A.; Cavagnino, A.; Tenconi, A.; Vaschetto, S. "The Safety Critical Electric Machines and Drives in the More Electric Aircraft: a Survey", Conf. Rec. IEEE- IECON, (2009), pp. 2587-2594.
- [3] W. Cao; B. C. Mecrow, G. J. Atkinson, J. Glynn J.; et al., "Overview of Electric Motor Technologies Used for More Electric Aircraft (MEA)", IEEE Transactions on Industrial Electronics, vol. 59, no 9, (2012), pp. 3523-3531
- [4] Bottauscio O., Serra G., Zucca M., Chiampi M., "Role of magnetic materials in a novel electrical motogenerator for the "More Electric Aircraft"". IEEE Transactions on Magnetics, vol. 50, (2014), 8200704.
- [5] E. Levi, R. Bojoi, F. Profumo, H.A. Toliyat, S. Williamson, "Multiphase induction motor drives – a technology status review," IET Electr. Power Appl., vol. 1, no. 4, (2007), pp. 489-516
- [6] E. Levi, "Multiphase electric machines for variable-speed applications", IEEE Transactions on Industrial Electronics, Vol. 55, no 5., (2008), pp 1893-1909
- [7] Bottauscio O., Chiampi M., Zucca M., "Experimental and numerical investigations on rotational fluxes in stator cores of three-phase motors", IEEE Trans. Magn., Vol. 38, No. 5, (2002), pp. 3294-3296.
- [8] Bottauscio O., Chiampi M., Manzin A., and Zucca, "Additional losses in induction machines under synchronous no-load conditions," IEEE Trans. Magn. , vol. 40, no. 5, (2004), pp. 3254–3261
- [9] D. Sedira, M. R. Mekideche, A. Kedous-Lebouc, et al., "Evaluation of magnetic forces in an induction machine with dual stator winding taking 172 into account hysteresis model", COMPEL, vol. 30, no 1, (2011), pp 172-185
- [10] Bottauscio O. and Chiampi M., "Laminated core modelling under rotational excitations including eddy currents and hysteresis," J. Appl. Phys., vol. 89, no. 11, (2001), pp. 6728–6730.
- [11] Beatrice C., Appino C., De la Barrière O., Fiorillo F. and Ragusa C., "Broadband Magnetic Losses in Fe-Si and Fe-Co Laminations", IEEE Trans. Magn., Vol. 50, No. 4, (2014), 6300504.