



ISTITUTO NAZIONALE DI RICERCA METROLOGICA Repository Istituzionale

GPS-navigator: an advanced search engine to gather information and navigate through standards in the field of geometrical product specification

Original

GPS-navigator: an advanced search engine to gather information and navigate through standards in the field of geometrical product specification / Bodini, Ileana; Baronio, Gabriele; Paderno, Diego; Villa, Valerio; Martinelli, Paolo; Frizza, Roberto; Balsamo, Alessandro; Uberti, Stefano. - In: INTERNATIONAL JOURNAL ON INTERACTIVE DESIGN AND MANUFACTURING. - ISSN 1955-2513. - (2024). [10.1007/s12008-023-01647-4]

Availability:

This version is available at: 11696/80221 since: 2024-03-03T19:08:01Z

Publisher:

SPRINGER HEIDELBERG

Published

DOI:10.1007/s12008-023-01647-4

Terms of use:

This article is made available under terms and conditions as specified in the corresponding bibliographic description in the repository

Publisher copyright

SPRINGER

Copyright © Springer. The final publication is available at link.springer.com

(Article begins on next page)



GPS-navigator: an advanced search engine to gather information and navigate through standards in the field of geometrical product specification

Ileana Bodini¹ · Gabriele Baronio¹ · Diego Paderno¹ · Valerio Villa¹ · Paolo Martinelli¹ · Roberto Frizza² · Alessandro Balsamo³ · Stefano Uberti¹

Received: 14 September 2022 / Accepted: 17 October 2023

© The Author(s), under exclusive licence to Springer-Verlag France SAS, part of Springer Nature 2023

Abstract

The Geometrical Product Specification (GPS) and the Geometrical Dimensioning and Tolerancing (GD&T) are communication languages to code the tolerable morphology of manufactured parts and assemblies. Both languages should be unambiguous tools to communicate such information between designers, process engineers, and Coordinate Measuring Machines operators (CMM). GPS is the one developed in the ISO (International Organization for Standardization) environment. GPS language is a complex code of 143 standard with further 15 under development. Moreover, as in each complex body of standards, most of them recalls other standards in a very intricate manner. So, the need to have a flexible tool to search and navigate through the standards is great, as is the need to optimize the work of the designer and to minimize the design, production, and control costs. The basic effort in building such a tool has been the development of the database and the structure for the search engine, called “GPS Navigator”. In the following, the requirements for the coding phase have also been issued, to realize a powerful, efficient, fast, robust, and rigorous tool to navigate through the GPS standards. The final step of the “GPS-Navigator project” is the delivery of a software tool able to help and guide the designer to quickly consult the appropriate standard or set of standards.

Keywords Geometrical product specifications (GPS) · Database · Advanced search criteria · Design methods

1 Introduction

The Geometrical Product Specification (GPS) and the Geometrical Dimensioning and Tolerancing (GD&T) languages are the most powerful tools available to link the “perfect” geometrical world of the CAD models to the imperfect world of manufactured parts and assemblies. GPS and GD&T should be unambiguous common languages between designers, process engineers, and Coordinate Measuring Machines operators (CMM) in the ISO (International Organization for Standardization) and ASME (American Society of Mechanical Engineers) environments, respectively [1]. Teaching of

this subject is well established in all the technical universities, as there are also good reference books and texts on the subject [1–3].

Being able to understand this language is paramount for design engineers as for production quality control technicians as well as for manufacturing operators.

There have been countless efforts in the direction of the simplification of the workload of the tolerancing or product specifications on the operators in all the phases of the product lifecycle, as exemplified in [4–6] about the design phase or in [7] about the inspection phase.

In the same way, many tools have been developed to help in the analysis of the tolerance stack, once it has been assigned as in [8, 9]. The problem is double sided: it can be seen from the tolerance analysis side (typical during fabrication or during final controls) or from the designer point of view; in this latter case it is a typical synthesis problem. Approaches in the development of preparatory material [3] or in the coding of support software [10] are as old as the subject of tolerances itself.

✉ Ileana Bodini
ileana.bodini@unibs.it

¹ DIMI, Università degli studi di Brescia, Brescia, Italy

² MG Marposs, Brescia, Italy

³ INRIM, Turin, Italy

Since the information chain about Product Specifications and tolerances originates during the design phase of a project, it could be seen as a typical decision-making problem in a project initial stretch of road [11]

In this paper we would like to narrow the field to the GPS standards, because they are the ones adopted in almost all Europe and because they are also the most numerous. Consequently, it is easier “to get lost” among them. The whole GPS standards set is under continuous development through the cooperation of 26 participating members and 27 observers, and currently includes 143 standards, while 15 others are currently being developed [12].

GPS standards have been considered in several works as an integral part of the production chain of a product, from its design to its final control, passing through production and processing. Their knowledge and correct application have often been considered as fundamental medium to reduce the overall cost of a certain product [13–16]. Even if GPS standards have been increasingly taught at engineering schools or in basic tolerancing classes, many circulating drawings are still prone to ambiguity of interpretation and do not communicate true functional requirements of the parts.

Potential savings related to the correct implementation of GPS language are generated by trying to eliminate all the losses related with an incorrect management of tolerances. All companies involved in designing or manufacturing mechanical parts can benefit from a correct usage of GPS, but advantages are greatest for those companies outsourcing the manufacturing of parts because these companies, more than any others, need their drawings to clearly communicate functional requirements, univocally, not ambiguously; it is worth to say that extra cost are not only due to rejected parts but also with unnecessary operations related with tight dimensional prescriptions [14–17].

Being GPS such a wide set of standards it is very common that an operator bounces from a standard to the other following the flux of cited references, somehow getting lost in the “mare magnum” of formulas and information. It is useful to recall here that some standards could be identified as more related with the measurement process than with the design phase.

There have been many attempts in synthesizing GPS standards [14, 18–20], providing guidelines or simplifications [1, 13, 14, 17–20] or otherwise creating a new language [21]; in all cases, authors of these studies highlighted the need to provide guidance in choosing and applying standards, in order to reach the best communication level during the first phase of the product lifecycle.

Moreover, the product specification for a physical object is not a problem with a one and only solution, the task is to give correct functionality to this object, while using the simplest way of expressing it and at the same time choosing the

prescriptions that translate in the most economic flux of operations with the following measurement campaign. The basic task could have potentially lots of solutions, while the best solution must be sought after, looking through the standards.

Designer is typically aware of the functionalities of the product but lacks the ability to translate this into correct specifications.

In the moving chain of information related with product design and development, designer is often the weakest link since he must formalize and express the desired prescriptions with clear terms and a proper language that can sometimes be cryptic. Whatever the complexity of a drawing, not all the 143 standards are needed to understand it, therefore having a tool that allows the designer to find the group of appropriate standards to reach the functional requirements of the component can be extremely useful.

Present work originates from all the aforementioned needs, first of which is the correct choice of the most appropriate set of rules to convert the functional requirement into an appropriate graphic sign on the drawing. The aim is to provide users with a list of related standards that makes it easy to consult them. It appears from the authors’ experience that this aspect is by no means a given, in fact, in each standard the related ones are not indicated. It is possible to find them only by cross-referencing the reading of the standards with consultation of the ISO (or UNI-ISO) site. Such work is time-consuming, because often not all the standards indicated by a search of the specific sites are really relevant to the specification of interest.

This paper presents the first step of a project aimed to deliver a software tool able to help and guide the designer to quickly consult the appropriate standard or set of standards [22]. In particular, the presented work describes the development of an advanced search engine, named “GPS Navigator”, to help designers in untangling themselves among ISO GPS standards. The database and the structure of this system have been developed and made available, and the specifications for the coding of the GPS Navigator search engine were studied and provided as well. All standards were included in the database following the setting from the GPS matrix, and three macro-search modalities were defined. Each of the three macro search criteria is detailed in sub-criteria, depending, for example, on the type of information to search for, the initial information from which to originate the search itself, or the type of purpose the search has (i.e., search for a set of standards, for a specific standard, for the bibliography on a certain specification, etc....).

2 Methods

GPS Navigator is an advanced search engine that facilitates designers in their search for GPS information or standards,

starting from a simple keyword, e.g., the functional aim of the component, or the required form.

ISO 14638:2015 standard, defines the geometrical specifications through the GPS Matrix shown in Fig. 1. The GPS Matrix is composed of 9 rows and 7 columns: the rows are the geometric properties, and the columns are the position of the product in the production chain. Here, three sections are highlighted: specification (first 3 columns, highlighted in red in Fig. 1); comparison and decision rules (fourth column, highlighted in green in Fig. 1); verification (remaining 3 columns, highlighted in yellow in Fig. 1). These three sections should correspond to the possible search areas of the user of the proposed search engine. The search result can be a standard or a set of standards belonging to one of the sections listed above.

ISO 14638:2015 also specifies the classification of all the GPS International Standards into three categories, according with matrix model in Fig. 1:

- fundamental standards, which occupy all boxes of the model of matrix;
- general standards, which occupy one or more boxes of the model of matrix;
- complementary standards, which occupy one or more boxes of a row occasionally added at the bottom of matrix model.

2.1 Database development

Currently, the database is an Excel table whose rows contain ISO GPS standards identification numbers while the columns represent the attributes that will be exploited during the search process which define the standard from different points of view.

Each standard of the ISO GPS has been analysed so far, and consequently different attributes representing probable search criteria have been inserted in an Excel spreadsheet for each standard: (i) ISO coding; (ii) UNI coding; (iii) Title; (iv) Type (Fundamental, General, or Complementary, according to ISO 14638); (v) Position in the GPS matrix (Matrix Position Coordinates ((1 ... 9); (A, ..., G)), i.e., Relationship to matrix model, according to ISO 14638); (vi) 3 levels of topics from general to specific (Type); (vii) Keywords; (viii) Index; (ix) Purpose; (x) Notes.

Each of these listed attributes is one of the possible search criteria.

In the following, three examples of how UNI EN ISO standards have been classified within the database.

The first example is about the fundamental standard ISO 8015:2011:

- UNI Code: UNI EN ISO 8015:2011.

- Class: Fundamental.
- Relationship to the GPS matrix model as in Fig. 2.
- 1st level topic: Fundamental indications.
- 2nd level topic: Fundamental concepts.
- 3rd level topic: Fundamental concepts, principles and rules valid for the creation, interpretation and application of all other International Standards.
- Keywords: GPS specification, drawings, principles, invocation principle, duality.
- Scope: This standard specifies fundamental concepts, principles, and rules valid for the creation, interpretation and application of all other International Standards, Technical Specifications and Technical Reports concerning geometrical product specifications (GPS) and verification

The second example is about the general standard ISO:2017:

- UNI Code: UNI EN ISO 1660:2017.
- Class: General.
- Relationship to the GPS matrix model as in Fig. 3.
- 1st level topic: Form.
- 2nd level topic: Profile and/or Surface tolerance.
- 3rd level topic: Profile tolerancing.
- Keywords: profile tolerancing, line profile, surface profile, integral feature, derived feature.
- Scope: This international standard gives the rules for geometrical specifications of integral and derived features, using the line profile and surface profile characteristic symbols as defined in ISO 1101.

The third example is about the complementary standard ISO 8062-1:2007:

- UNI Code: UNI EN ISO 8052-1:2007.
- Class: Complementary.
- Relationship to the GPS matrix model as in Fig. 4.
- 1st level topic: Moulded parts.
- 2nd level topic: Moulded parts—dimensional and geometrical tolerances.
- 3rd level topic: Vocabulary.
- Keywords: moulded parts, geometrical tolerances, manufacturing equipment, manufacturing process, mismatch, surface imperfections.
- Scope: ISO 8062-1:2007 establishes a vocabulary of terms and definitions used to describe the features, form and tolerance types when assigning dimensional and geometrical tolerances to moulded parts in geometrical product specifications (GPS).

This type of classification has been performed for all the standards of the ISO GPS system.

GPS MATRIX	A Symbols and indications	B Feature requirements	C Feature properties	D Conformance and non-conformance	E Measurement	F Measurement equipment	G Calibrations
1 Size							
2 Distance							
3 Form							
4 Orientation							
5 Location							
6 Run-out							
7 Profile surface texture							
8 Areal surface texture							
9 Surface imperfections							

Fig. 1 GPS matrix structure

GPS MATRIX	A Symbols and indications	B Feature requirements	C Feature properties	D Conformance and non-conformance	E Measurement	F Measurement equipment	G Calibrations
1 Size	•	•	•	•	•	•	•
2 Distance	•	•	•	•	•	•	•
3 Form	•	•	•	•	•	•	•
4 Orientation	•	•	•	•	•	•	•
5 Location	•	•	•	•	•	•	•
6 Run-out	•	•	•	•	•	•	•
7 Profile surface texture	•	•	•	•	•	•	•
8 Areal surface texture	•	•	•	•	•	•	•
9 Surface imperfections	•	•	•	•	•	•	•

Fig. 2 Relationship of the ISO 8015:2011 to the GPS Matrix Model

GPS MATRIX	A Symbols and indications	B Feature requirements	C Feature properties	D Conformance and non-conformance	E Measurement	F Measurement equipment	G Calibrations
1 Size							
2 Distance							
3 Form	•	•	•				
4 Orientation	•	•	•				
5 Location	•	•	•				
6 Run-out							
7 Profile surface texture							
8 Areal surface texture							
9 Surface imperfections							

Fig. 3 Relationship of the ISO 1660:2017 to the GPS Matrix Model

GPS MATRIX	A Symbols and indications	B Feature requirements	C Feature properties	D Conformance and non-conformance	E Measurement	F Measurement equipment	G Calibrations
1 Size							
2 Distance							
3 Form							
4 Orientation							
5 Location							
6 Run-out							
7 Profile surface texture							
8 Areal surface texture							
9 Surface imperfections							
Standards on mouldings	•	•					

Fig. 4 Relationship of the ISO 8062–1:2007 to the GPS Matrix Model

2.2 Definition of the search criteria

Each of the following attributes described in the Excel spreadsheet database is a possible research criterium: (i) ISO coding; (ii) UNI coding; (iii) title; (iv) type; (v) position in the GPS matrix; (vi) 3 levels of topics from general to specific (Type); (vii) keywords; (viii) index; (ix) purpose; (x) notes.

The output of the search activity could be essentially a standard or a list of standards presented to the user with a configurable list of the attributes stored in the database.

The following search modalities have been hypothesized: (i) free search; (ii) simple guided search; (iii) advanced guided search.

Free search. (FS) This search is the simplest one and can be accomplished in two ways:

1. *free keyword search*: the user can type a keyword and search for all standards that have the requested word in the title, summary, or at least one of the possible 'attributes' defined in the database.
2. *search by ISO coding*: the user can type in the ISO code and search for the corresponding standard.

Simple guided search. (SGS) The following are the types of guided search that the proposed system provides:

1. *guided keyword search*: one or more keywords have been associated with each of the standards; when the operator decides to use the keyword search wizard the alphabetical list of keywords should appear allowing the user to select the one of interest.
2. *guided symbol search*: by selecting the symbol search the user is presented with a list of symbols found in the various standards and usable in the specification; when

the symbol is chosen, a brief description appears with the normative reference of the standard(s) introducing it.

3. *macro-topic attribute search*: each standard has been assigned macro-topic definitions to summarise its content. macro topics have three levels, so that each standard is assigned three macro-topics that go from level 1 to 3, gradually detailing the subject of the standard. Searching by macro topics can therefore also be performed on three levels.
 - a. *1st level macro topic search*: as mentioned above, each standard has a '1st level macro-topic' attribute, which summarises in less than one line (sometimes one word) the main topic it deals with. When the operator decides to use this type of search, the alphabetical list of 1st level macro topics appears, allowing the user to select the one of interest. Once the topic of interest has been selected, it is possible to proceed to the list of 2nd level macro topics and then to the list of 3rd level macro topics, or to provide immediately the list of all standards belonging to the different levels.
 - b. *2nd level macro-topic search*: as mentioned, each standard has a '2nd level macro topic' attribute which very briefly describes the topic declared in level 1. When the operator decides to use this type of search, the alphabetical list of 2nd level macro topics appears alongside the list of level 1 macro topics, allowing the user to select the one of interest. The path is the same as for the 1st level macro topic search, the user in this case skips the first level.
 - c. *3rd level macro-topic search*: as mentioned, each standard has a "3rd level macro-topic" attribute which very briefly describes the topic enunciated in levels 1 and 2. When the operator decides to use this type

of search, the alphabetical list of 3rd level macro topics appears next to the path of the different levels, allowing the user to select the one of interest.

4. *Search by GPS standards classification:* GPS standards have a hierarchical structure and are classified into Fundamental, General, Complementary. The user has the possibility of listing for each of the categories the rules that belong to them, and the search provides the 3 options with their definition:
 - a. *fundamental:* such standards are fundamental rules and procedures for the whole system, they occupy all the boxes of the matrix.
 - b. *general:* such standards affect one or more rows or one or more columns, but they are not fundamental, they occupy one or more but not all the boxes in the
 - c. *complementary:* these rules are specific to individual machining processes or specific machine elements; a line is added to the bottom of the matrix if needed.
5. *Search by position in GPS Matrix.* The system exploits a classification according to the matrix illustrated in the ISO 14638 standard, which places each standard in a two-dimensional matrix in which the columns with 7 divisions follow the product's production cycle and the 9 rows specify the subject(s) dealt with. By indexing the columns with the letters from a to g and the rows with the numbers 1 to 9, the operator can request, for example, the list of standards that deal with the specific topic "symbols and indications" on the topic "orientation" by entering the two-dimensional coordinate a4 in the search, or alternatively, the user can select the box of interest in the matrix model. When necessary, any complementary standard rows are also added to the matrix.

Advanced guided search. (AGS) The intent is to guide the user through different paths or collections of standards with a pre-established order, which should enable a specific subject to be dealt with. The suggested order should consent a didactic approach to the user, who gradually is introduced to the standards of the collection, looking at each topic with the necessary preliminary knowledge. Different types of searches are possible:

1. *the "preparatory path"* aims to enable the user to acquire the background knowledge needed to understand how the GPS system is structured and the specific content of the various standards that it is composed of. The path to be followed is shown in Fig. 5, described as follows:
 - a. System basics
 - (1) ISO 14638 (Matrix model)
 - (2) ISO 21619 (Type of GPS document)
 - (3) ISO 23605 (ISO GPS and TPD index for TPS)

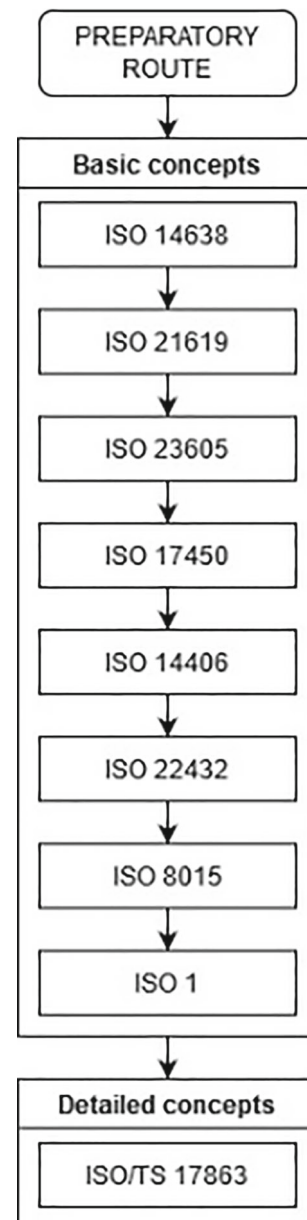
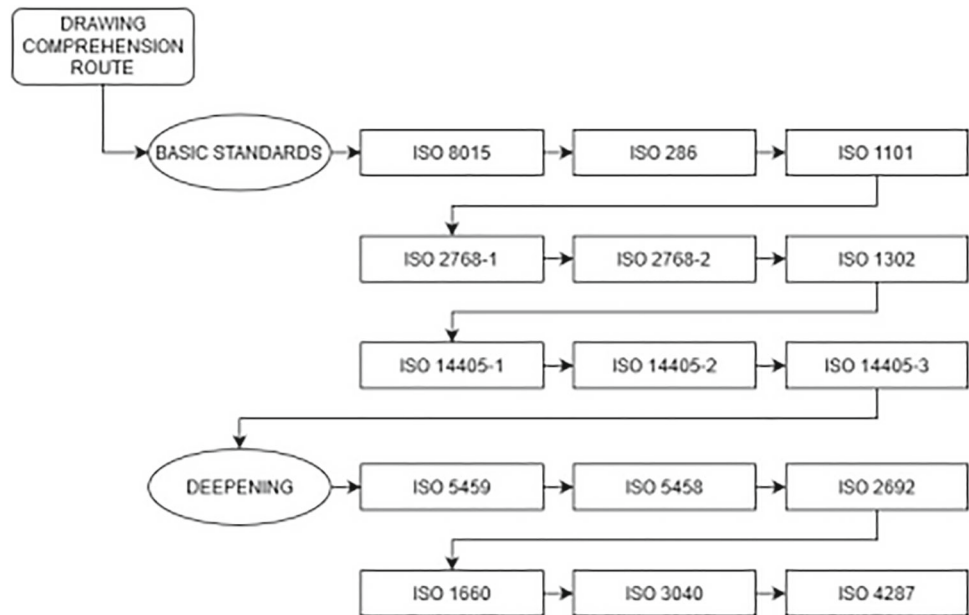
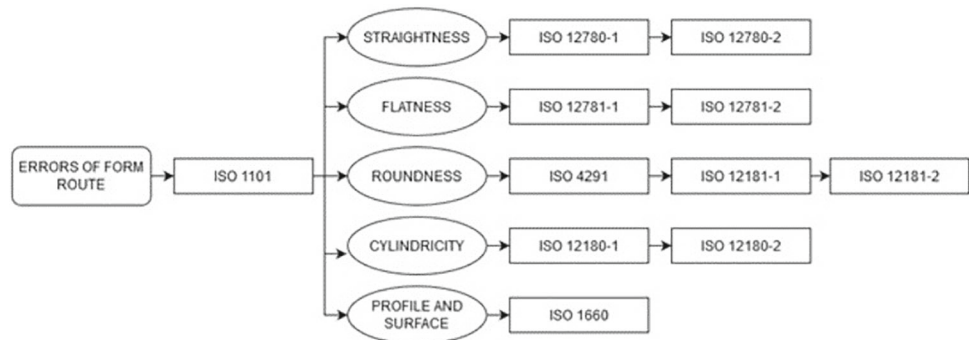
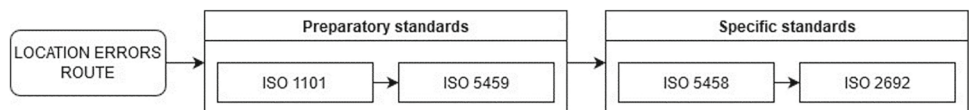

Fig. 5 Preparatory path

- (4) ISO 17450 (General concepts)
- (5) ISO 14460 (Extraction)
- (6) ISO 22432 (General terms and types of features)
- (7) ISO 8015 (Fundamental principles)
- (8) ISO 1 (Reference temperature)
- b. Detailed rules
 - (1) ISO/TS 17863 (Tolerancing of moveable assemblies)
3. *the "drawing comprehension path"* aims to enable the user to understand the specification requirements expressed on a drawing. Before using the standard search criterion for drawing understanding, it is advisable to

Fig. 6 Drawing comprehension path**Fig. 7** Form error path**Fig. 8** Location error path

have acquired the skills of the preparatory course. The path to be followed is shown in Fig. 6, described as follows:

i. basic standards

- (1) ISO 8015 (Fundamental principles)
- (2) ISO 286 (ISO principles – hole/shafts tolerances)
- (3) ISO 1101 (Geometric tolerances)
- (4) ISO 2768–1 (General tolerances)
- (5) ISO 2768–2 (General tolerances)
- (6) ISO 1302 (Surface texture indications)
- (7) ISO 14405–1 (Dimensional tolerances—sizes)
- (8) ISO 14405–2 (Dimensional tolerances—Dimensions other than linear or angular sizes)
- (9) ISO 14405–3 (Dimensional tolerances—angular sizes)

j. deepening

- (1) ISO 5459 (Datums)
- (2) ISO 5458 (Location tolerances)
- (3) ISO 2692 (Maximum material, least material, reciprocity requirement)
- (4) ISO 1660 (Profile tolerancing)
- (5) ISO 3040 (Dimensioning and tolerances of cones)
- (6) ISO 4287 (Roughness – definitions and parameters)

3. the “form errors” path aims to guide the user in deepening form errors comprehension, considering both specification and verification aspects. The path to be followed is shown in Fig. 7, described as follows:

- k. preparatory standards (general concepts and definitions):

- (1) ISO 1101 (Geometric tolerances)
- l. specific standards (linearity errors)
 - (1) ISO 12780-1 (Straightness definitions)
 - (2) ISO 12780-2 (Straightness specification operators)
 - m. 3specific standards (flatness errors)
 - (1) ISO 12781-1 (Flatness definitions)
 - (2) ISO 12781-2 (Flatness specification operators)
 - n. specific standards (roundness errors):
 - (1) ISO 4291 (Classification methods of instruments for roundness detection)
 - (2) ISO 12181-1 (Roundness definitions)
 - (3) ISO 12181-2 (Roundness specification operators)
 - o. specific standards (cylindricity errors)
 - (1) ISO 12180-1 (Cylindricity definitions)
 - (2) ISO 12180-2 (Cylindricity specification operators)
 - p. specific standards (profile and free-form surface errors)
 - (1) ISO 1660 (Profile tolerancing)
4. the “location errors path” aims to show the user the available standards to comprehend location errors considering both specification and verification aspects. The path to be followed is shown in Fig. 8, described as follows:
- q. preparatory standards (general concepts and definitions):
 - (1) ISO 1101 (Geometric tolerances)
 - (2) ISO 5459 (Datums)
 - r. specific standards
 - (1) ISO 5458 (Location tolerances)
 - (2) ISO 2692 (Maximum materials, least material, reciprocity requirement)
- the “surface micro-geometric errors” path aims to show the user the available standards to understand surface texture errors considering both specification and verification aspects, through two possible strategies: the profile method. The path to be followed is shown in Fig. 9, described as follows:
- (1) preparatory rules (general concepts and definitions)
 - i. ISO 1302 (Surface texture indications)
 - ii. ISO 4287 (Definitions and parameters of roughness)
 - iii. ISO 13565–1 (Filtration and measurement general conditions for surfaces having stratified functional properties)
 - iv. ISO 13565–2 (Definitions parameters by linear material ratio curve)
 - v. ISO 13565–3 (Definitions parameters by material probability curve)
 - vi. ISO 12085 (Waviness terms and definitions)

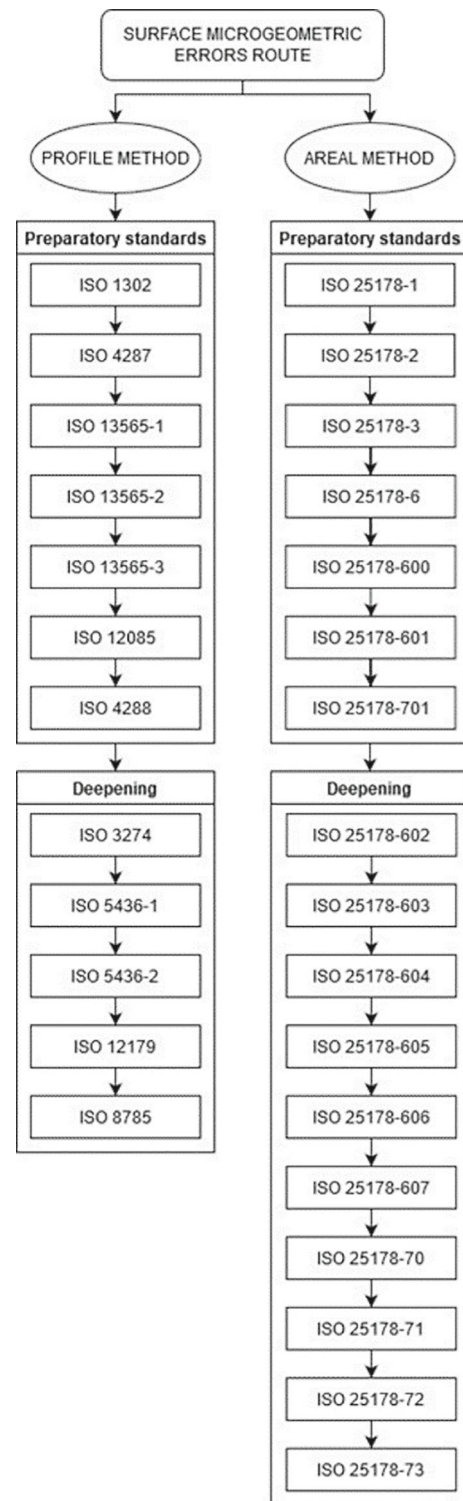
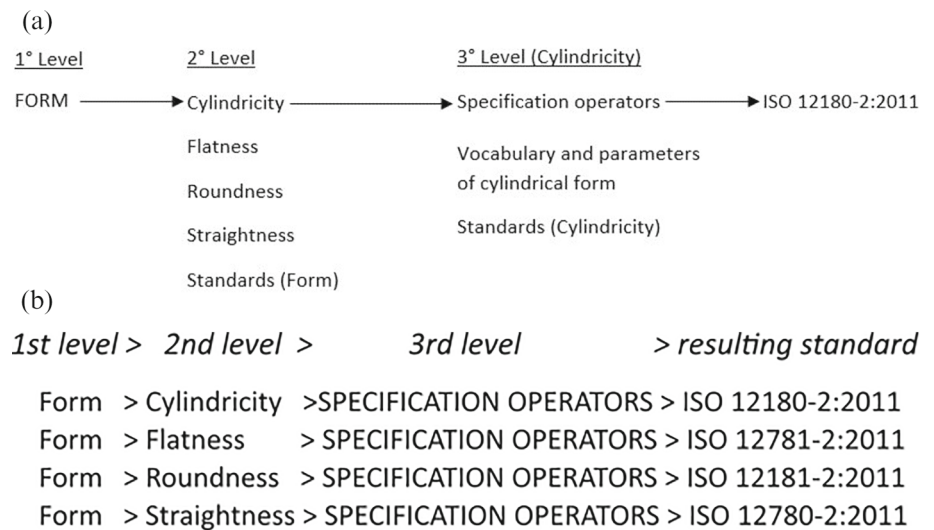

Fig. 9 Surface micro-geometric errors path

Fig. 10 Example of a complete topic search. (a) Example of the standard for specification operators in the case of a second level search for “Cylindricity”. (b) Result if the third level search is “specification operators”



vii. ISO 4288 (Rules and procedures for the assessment of surface texture)

(2) Deepening

- i. ISO 3274 (Nominal characteristics of contact (stylus) instruments)
- ii. ISO 5436-1 (Material measures)
- iii. ISO 5436-2 (Software measurement standards)
- iv. ISO 12179 (Calibration of contact instruments)
- v. ISO 8785 (Surface imperfections)

the areal method. The path to be followed is shown in Fig. 9, described as follows:

(1) preparatory rules (general concepts and definitions)

- i. ISO 25178-1 (Indication of surface texture)
- ii. ISO 25178-2 (Terms, definitions, and surface texture parameters)
- iii. ISO 25178-3 (Specification operators)
- iv. ISO 25178-6 (Classification of methods for measuring surface texture)
- v. ISO 25178-600 (Characteristics of areal instruments for measuring surface topography)
- vi. ISO 25178-601 (Nominal characteristics of contact instruments)
- vii. ISO 25178-701 (Calibration and measurement standards for contact instruments)

(2) Deepening

- i. ISO 25178-602 (Nominal characteristics of non-contact instruments: confocal chromatic probe)
- ii. ISO 25178-603 (Nominal characteristics of non-contact instruments: phase-shifting interferometric microscopy)

iii. ISO 25178-604 (Nominal characteristics of non-contact instruments: coherence scanning interferometry)

iv. ISO 25178-605 (Nominal characteristics of non-contact instruments: point autofocus probe)

v. ISO 25178-606 (Nominal characteristics of non-contact instruments: focus variation)

vi. ISO 25178-607 (Nominal characteristics of non-contact instruments: confocal microscopy)

vii. ISO 25178-70 (Material measures)

viii. ISO 25178-71 (Software measurement standards)

ix. ISO 25178-72 (XML file format x3p)

x. ISO 25178-73 (Terms and definitions for surface defects on material measures)

3 Results and discussion

In the following, examples of possible research methods are detailed.

Figure 10a shows a complete topic search, included in the simple guided search mode. This research flows through three different levels. The 1st level topic sums up the main search argument in less of a line, and a list of alphabetically ordered 1st level topics are presented to the user. In the presented case the user chooses “FORM”, as 1st level topic, then a list of 2nd level topics related to the chosen ones is shown. The user chooses “Cylindricity”, then a list of 3rd level topics appears. The user chooses “Specification operators” and finally the related standard is retrieved.

Figure 10b shows a third level topic research: when the user selects the topic of interest, the path of different levels

	A	B	C	D	E	F	G	
1	286-1,2 1119 2538-1,2 2692 3040 5459 14405-1,3 17863	286-1,2 1119 2538-1,2 2692 3040 5459 14405-1,3 17863	2538-2 2692 5459 14253-4 14405-1,3 14406 10610-series 17863	14253-1,2,3,4 16015	1938-1 14253-2,3,4,6 16015	463 1938-1,2 3611 9493 10360 13102 13225 13385-1,2 14253-2,3,4,5,6	14253-2,3,4,5,6 14406 14978 16015 16610* 17865 23165	1938-1,2 3650 13385-1 14253-2,3,4,6 14978 15530-1,3,4 16015 16610-1
	14405-2 17863	17863	14253-4 14406 10610-series 17863	14253-1,2,3,4 16015	14253-2,3,4,6 16015	463 9493 10360 13102 13225 13385-1,2 14253-2,3,4,5,6	14406 14978 16015 16610* 17865 23165	3650 13385-1 14253-2,3,4,6 14978 15530-1,3,4 16015 16610-1
3	1101 1660 2692 3040 5458 5459 10579 17863	1101 1660 2692 3040 5458 5459 10579 12181-1 12781-1 17863	1101 1660 2692 5458 5459 12180-2 12181-2 12781-2 14253-4 14406 10610-series 17863	14253-1,2,3,4 16015	14253-2,3,4,6 16015	463 9493 10360 14253-2,3,4,5,6 14406 14978 16015 16610* 17865 23165	14253-2,3,4,6 14978 15530-1,3,4 16015 16610-1	
	1101 1660 2692 3040 5458 5459 10579 17863	1101 1660 2692 3040 5458 5459 10579 12781-1 17863	1101 1660 2692 5458 5459 10579 12181-1 14406 10610-series 17863	14253-1,2,3,4 16015	14253-2,3,4,6 16015	463 9493 10360 14253-2,3,4,5,6 14406 14978 16015 16610* 17865	14253-2,3,4,6 14978 15530-1,3,4 16015 16610-1	
5	1101 1660 2692 3040 5458 5459 10579 17863	1101 1660 2692 3040 5458 5459 10579 17863	1101 1660 2692 5458 5459 10579 14253-4 14406 10610-series 17863	14253-1,2,3,4 16015	14253-2,3,4,6 16015	463 9493 10360 14253-2,3,4,5,6 14406 15530-1,3,4 16610* 17865 23165	14253-2,3,4,6 14978 16610-1	
	1101 1660 2692 3040 5458 5459 10579 17863	1101 1660 2692 3040 5458 5459 10579 17863	1101 1660 2692 5458 5459 10579 14406 10610-series 17863	14253-1,2,3,4 16015	14253-2,3,4,6 16015	463 9493 10360 14253-2,3,4,5,6 14406 14978 16015 16610* 17865 23165	14253-2,3,4,6 14978 16610-1	
6	1101 3040 5459 10579 17863	1101 3040 5459 10579 17863	1101 1660 2692 5458 5459 10579 14253-4 14406 10610-series 17863	14253-1,2,3,4 16015	14253-2,3,4,6 16015	463 9493 10360 14253-2,3,4,5,6 14406	14978 16015 16610* 23165	14253-2,3,4,6 14978 15530-1,3,4 16015 16610-1
	1302 5459	4287 5459 13085 13565-1,2,3	4288 5459 13085 13565-1 14253-4 14406 10610-series	4288 12085 14253-1,2,3,4 16015	4288 12085 14253-2,3,4,6 16015	3274 14253-2,3,4,5,6 14406 14978 16015	16610* 17865 21165 25178-600,601,602, 604,605,607,6,73	5436-1,2 12179 14253-2,3,4,6 14978 16015 16610-1
8	5459 25178-1	5459 25178-2	5459 14253-4 14406 10610-series 25178-3	14253-1,2,3,4 16015	14253-2,3,4,6 16015	14253-2,3,4,5,6 14406 14978 16015	16610* 17865 23165 25178-600-607,6,72,73	14253-2,3,4,6 14978 16015 16610-1 25178-701,70,71
	8785	8785	14253-4 14406 10610-series	14253-1,2,3,4 16015	14253-2,3,4,6 16015	14253-2,3,4,5,6 14406 14978 16015	16610* 17865 23165 25178-73	14253-2,3,4,6 14978 16015 16610-1

*without 1660-1,31,32,85

Fig. 11 Relationship of general ISO standards to the matrix model

appears to avoid ambiguity. In Fig. 10b the choice is the third level topic "Specification operators", and all the second level topics that has such a third level are presented.

Figure 11 shows the relationship of general ISO standards to the matrix model, included in the "simple guided search" mode. The columns and rows are indexed with letters from A to G and numbers from 1 to 9, respectively, and user can request standards indicating bidimensional coordinates. For example, the two-dimensional coordinate B1, provides the list of standards dealing with "Feature Requirements" on the subject "Size", and in the cell of the presented matrix all the standards regarding these attributes are listed.

4 Conclusions

The created database contains attributes to characterize each GPS Standard. Thanks to this work, it is possible to create an indexing strategy to cover the various searching methods of the GPS Navigator. The illustrated coding strategies (flowchart of search strategies) can create an environment where users can perform different searches according to the needs, from the simplest to the most structured one.

Current work results can be exploited for: (i) updating information about new standards or updated standards; (ii) data enrichment, especially the section of keywords and symbols; (iii) vocabulary enlargement, for example with the translation into other technical languages about product specifications, (iv) structured designer-oriented searches.

The final result will be soon online as a search engine supporting users in orientating themselves in GPS system to find and apply the standards of interest.

Acknowledgements This paper is presented as an extended version of the work published in [22], so some of the methods and results are the same as those found in [22].

References

1. Tornincasa, S.: Technical Drawing for Product Design. Springer, Cham (2021)
2. The GPS and GD&T Language. Tornincasa, S. Springer Tracts in Mechanical Engineering, 2021, pp. 49–79
3. Lee, W.-J., Woo, T.C.: Tolerances: their analysis and synthesis. *J. Manuf. Sci. Eng. Trans. ASME* **112**(2), 113–121 (1990)
4. Model-Based Approach for Optimal Allocation of GD&T. Petruccioli, A., Pini, F., Leali, F. *Lecture Notes in Mechanical Engineering*, 2022, pp. 277–284
5. Petruccioli, A., Pini, F., Leali, F.: Tolerance specification model for systematic application of GD&T in product design. In: ASME international mechanical engineering congress and exposition, proceedings (IMECE), **6**, V006T06A033 (2021)
6. Panari, D., Renzi, C., Vergnano, A., Bonazzi, E., Leali, F.: Integrated design method for optimal tolerance stack evaluation for top class automotive chassis. *Lecture Notes in Mechanical Engineering*, **2017**, (2017)

7. Bici, M., Campana, F., Trifiro, A., Testani, C.: Development of automatic tolerance inspection through reverse engineering. In: 2014 IEEE international workshop on metrology for aerospace, Metroaerospace 2014—Proceedings, 2014, pp. 107–112, 6865903
8. Petruccioli, A., Gherardini, F., Panari, D., Leali, F.: Computer-aided tolerancing analysis of a high-performance car engine assembly. *Lecture notes in mechanical engineering*, pp. 121–127 (2021)
9. Renzi, C., Ceruti, A., Leali, F.: Integrated geometrical and dimensional tolerances stack-up analysis for the design of mechanical assemblies: an application on marine engineering. *Book Chapter*
10. Islam, M.N.: Functional dimensioning and tolerancing software for concurrent engineering applications. *Comput. Ind.* **54**(2), 169–190 (2004)
11. Renzi, C., Leali, F.: Decision-making methods in engineering design: a designer-oriented approach. *Direccion y Organizacion* **63**, 21–49 (2017)
12. ISO/TC 213 Dimensional and geometrical product specifications and verification Home Page. <https://www.iso.org/committee/54924.html>, last accessed 2022/09/07.
13. Dantan, J.Y., Ballu, A., Mathieu, L.: Geometrical product specifications—model for product life cycle. *Comput. Aided Des.* **40**, 493–501 (2008)
14. Bennis, P., Nielsen, H.: An overview of GPS – A cost saving tool. Institute for Geometrical Product Specifications, Vaerloese (2005)
15. Mandolini, M., Campi, F., Favi, C., Germani, M., Raffaeli, R.: A framework for analytical cost estimation of mechanical components based on manufacturing knowledge representation. *Int. J. Adv. Manuf. Technol.* **107**, 1131–1151 (2020)
16. Vezzetti, E., Violante, M.G., Alemanni, M.: An integrated approach to support the Requirement Management (RM) tool customization for a collaborative scenario. *Int. J. Interact. Des. Manuf.* **11**, 191–204 (2017)
17. Schuldt, J., Hofmann, R., Gröger, S.: Introduction of a maturity model for assessment of the integration of the GPS system in companies. *Proc. CIRP* **92**, 129–133 (2020)
18. Nielsen, H.S.: The ISO Geometrical Product Specification Handbook. *Find Your Way in GPS. ISO/Danish Standards*, Denmark (2012)
19. Qi, Q., Scott, P.J., Jiang, X., Lu, W.: A hierarchical category model for geometrical product specification (GPS). *Proc. CIRP* **43**, 214–219 (2016)
20. Humlenny, Z.: State of art in standardization in GPS area. *CIRP J. Manuf. Sci. Technol.* **2**, 1–7 (2009)
21. Loureiro, G.B., Espindola Ferreira, J.C., Messerschmidt, P.H.Z.: Design structure network (DSN): a method to make explicit the product design specification process for mass customization. *Res. Eng. Design* **31**, 197–220 (2020)
22. Bodini, I. et al.: Proposal for a method for advanced search of information and standards in the field of geometrical product specification. In: Rizzi, C., Campana, F., Bici, M., Gherardini, F., Ingrassia, T., Cicconi, P. (Eds) *Design Tools and Methods in Industrial Engineering II. ADM 2021. Lecture Notes in Mechanical Engineering*. Springer, Cham https://doi.org/10.1007/978-3-030-91234-5_27. (2022)

Publisher's Note Springer Nature remains neutral with regard to jurisdictional claims in published maps and institutional affiliations.

Springer Nature or its licensor (e.g. a society or other partner) holds exclusive rights to this article under a publishing agreement with the author(s) or other rightsholder(s); author self-archiving of the accepted manuscript version of this article is solely governed by the terms of such publishing agreement and applicable law.