

INRiM (National Metrology Institute of Italy) contribution:

Alessandro Germak



EMPIR 18SIB08 ComTraForce

Comprehensive traceability for force metrology services

INRiM (National Metrology Institute of Italy) contribution:

- Team:

Alessandro **Germak** (Lead)

Andrea **Prato** (researcher, Phd in metrology)

Alessio **Facello** (technician, Phd in mechatronics)

Fabrizio **Mazzoleni** (technician, dipl. eng. in mechanics)

EMPIR 18SIB08 ComTraForce

Comprehensive traceability for force metrology services

INRiM (National Metrology Institute of Italy) contribution:

- Capabilities:
 - Dead weight primary standard machines:
 - 200 N ($U = 5 \times 10^{-5}$)
 - 1.3 kN ($U = 2 \times 10^{-5}$)
 - 30 kN ($U = 2 \times 10^{-5}$)
 - 100 kN ($U = 2 \times 10^{-5}$) (in progress a new 100 kN machine)
 - 1 MN ($U = 2 \times 10^{-5}$)
 - Reference transducers force standard machine:
 - 10 MN ($U = 5 \times 10^{-4}$)

C3.f Task 3.6: Development of a traceability chain for multicomponent forces and moments

The aim of this task is to extend the previous tasks (*Task 3.5: Development of a traceability chain for static and continuous force measurement*) into the development of a traceability chain for static and continuous multicomponent force and moment measurements at an uncertainty level suitable with classifications given in standardization (e.g. ISO 7500-1).

C3.f Task 3.6: Development of a traceability chain for multicomponent forces and moments

Activity number	Activity description	Partners (Lead in bold)
A3.6.1 M6	INRIM, Inmetro and TUBITAK will select at least two different types of multicomponent testing machines from industrial applications (e.g. spring testing machines, damper testing machines, etc). Selection will be based on the force and moment ranges (mid-high force scale, from kN to MN), and geometries.	INRIM , Inmetro, TUBITAK
A3.6.2 M6	Using input from A3.6.1, INRIM, Inmetro and TUBITAK will identify and select at least two different types of force transducers to act as suitable transfer standards for different multicomponent testing machines (e.g. strain cylinders, build-up systems, hexapod-shaped transducers, commercial multicomponent transducers), including an analysis of their interactions with the testing machines.	INRIM , Inmetro, TUBITAK
A3.6.3 M18	INRIM and TUBITAK will develop calibration procedures for each of the transfer standards selected in A3.6.2 (based on the outputs from EMRP project SIB63) and for the calibration of multicomponent testing machines, with an analysis of the associated uncertainty contributions.	INRIM , TUBITAK
A3.6.4 M26	INRIM, Inmetro and TUBITAK, using the selected transfer standards (A3.6.2), and according to the developed calibration procedures (A3.6.3) will measure multicomponent force and moment components on the different testing machines identified in A3.6.1 in order to calibrate them.	INRIM , Inmetro, TUBITAK
A3.6.5 M30	INRIM and TUBITAK will develop an uncertainty estimation model for multicomponent force and moment measurements in industrial applications (e.g. spring testing machine, robotics and dampers testing)	INRIM , TUBITAK

C3.f Task 3.6: Development of a traceability chain for multicomponent forces and moments

Machines:

- EUROLAB: special dynamic testing machine for structural and seismic matter;
- EUCENTER: dynamic testing systems for testing support, insulation and damping devices;
- EASYDUR: Spring testing machines

EUROLAB: special dynamic testing machine for structural and seismic matter (16 / 3,1 / 1,4 MN)

Vertical force (kN)	<i>16000</i>
Longitudinal force (kN)	<i>3100</i>
Lateral force (kN)	<i>1400</i>
Vertical displacement (\pm mm)	<i>35</i>
Longit. displacement (\pm mm)	<i>550</i>
Lateral displacement (\pm mm)	<i>375</i>
Vertical velocity (mm/s)	<i>55</i>
Longitudinal velocity (mm/s)	<i>1100</i>
Lateral velocity (mm/s)	<i>1100</i>



EUROLAB: special dynamic testing machine for structural and seismic matter (16 / 3,1 / 1,4 MN)

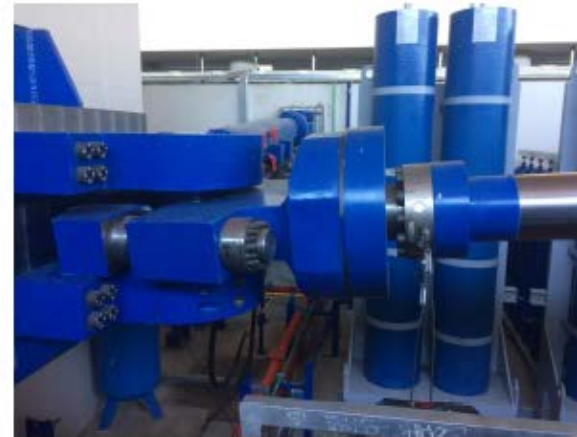
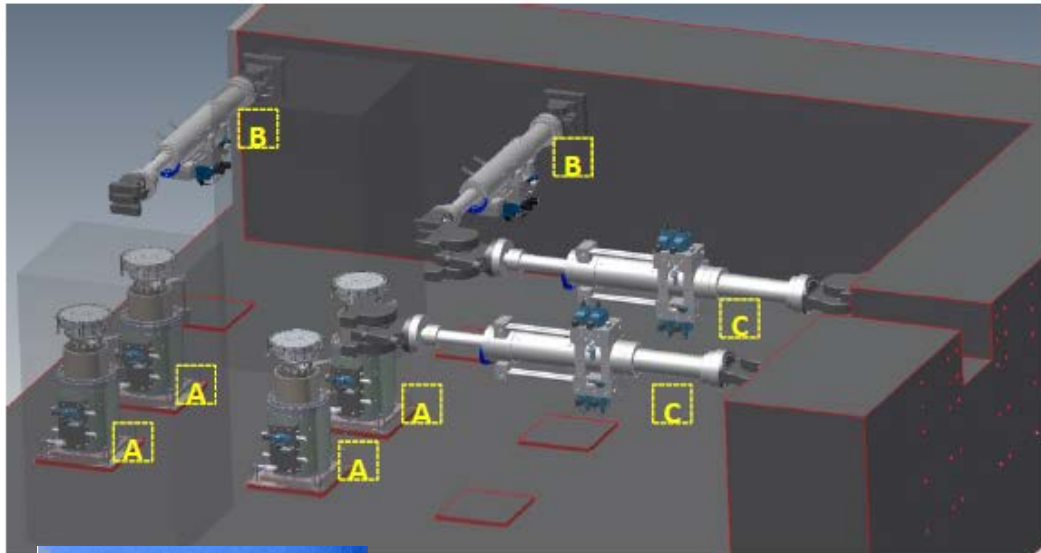

EUCENTER: dynamic testing systems for testing support, insulation and damping devices (4,4 MN)

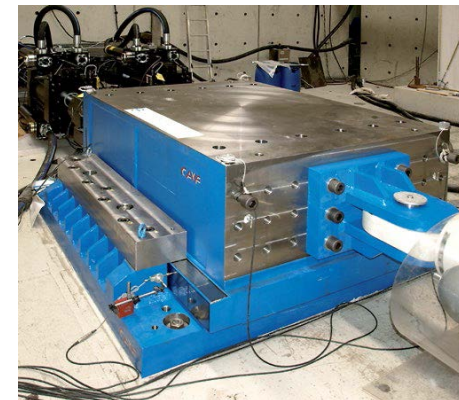
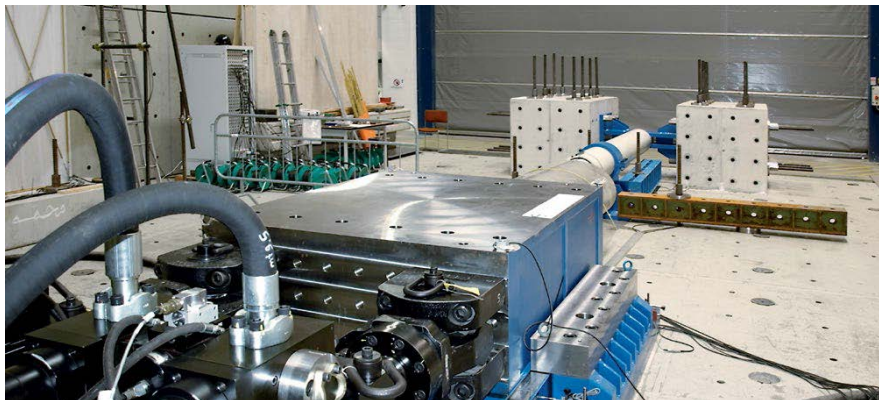
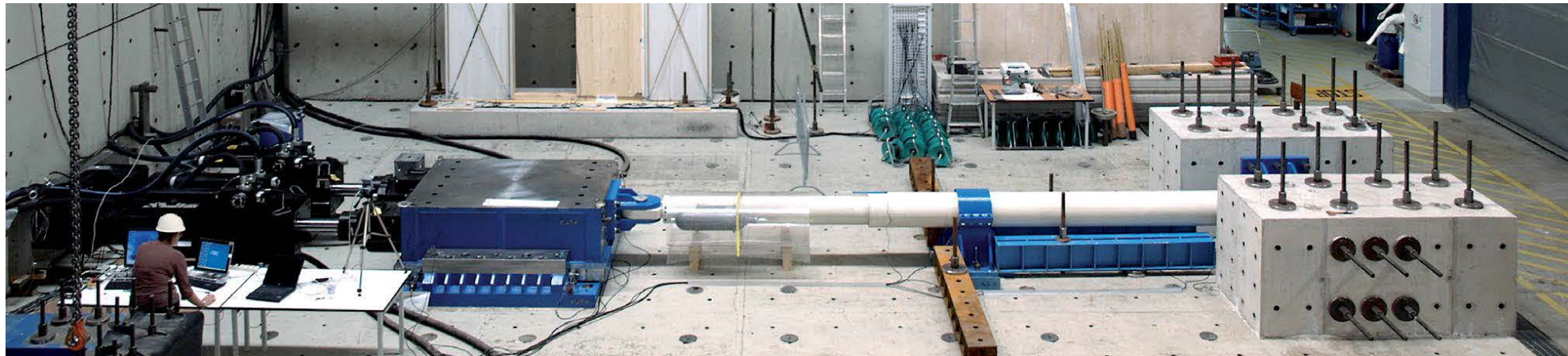

EUCENTER: Vibrating table with 4/6 degrees of freedom

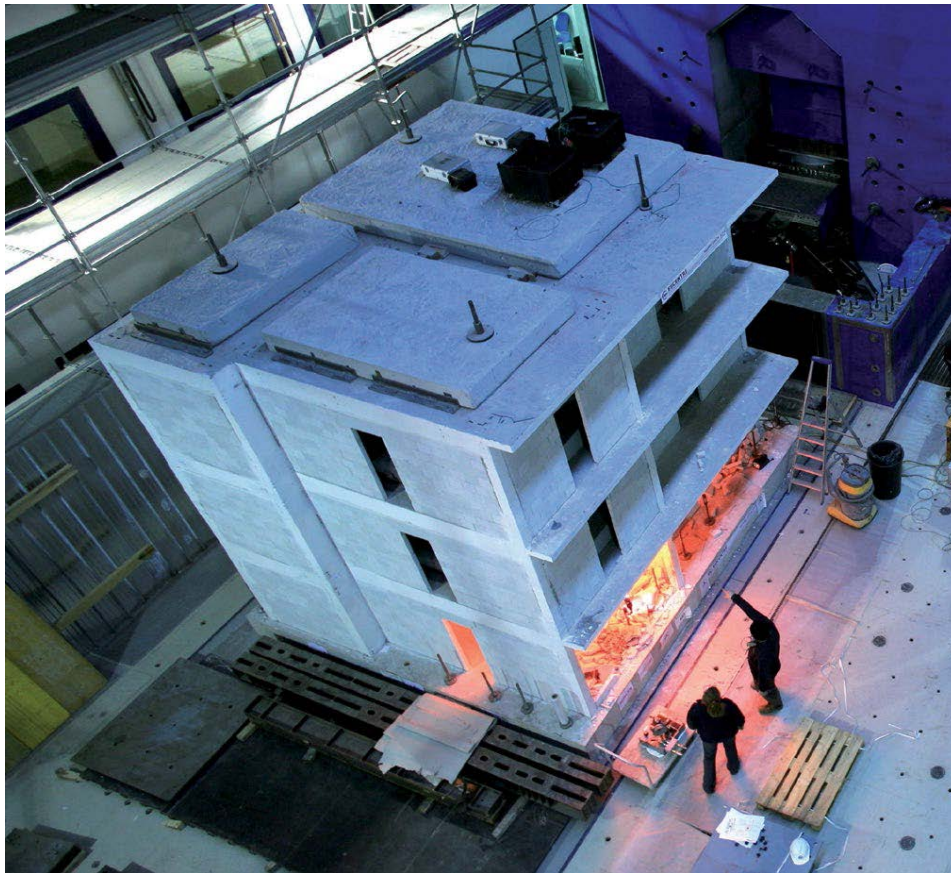

Acceleration: (1,8 to 6) g
Force: 1,7 MN (dynamic) - 2,2 MN (static)
Bending moment: 4 MNm
Frequency: 80 kHz

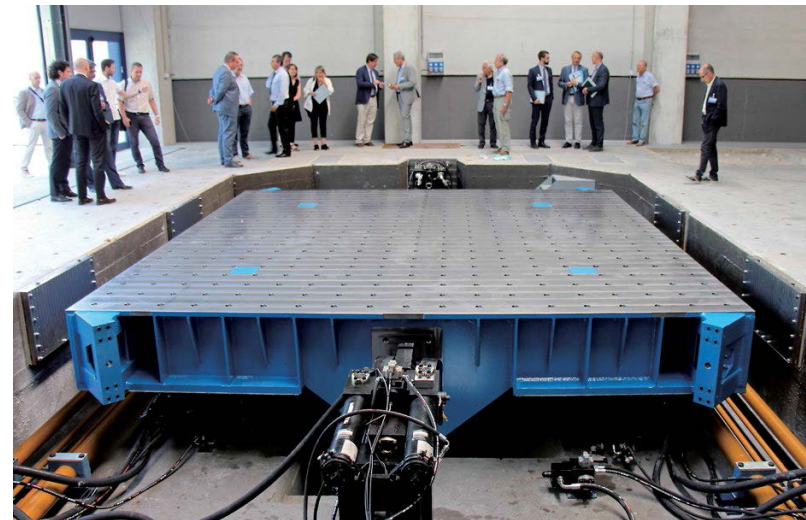

EASYDUR: Spring testing machines (400 / 100 / 100) kN

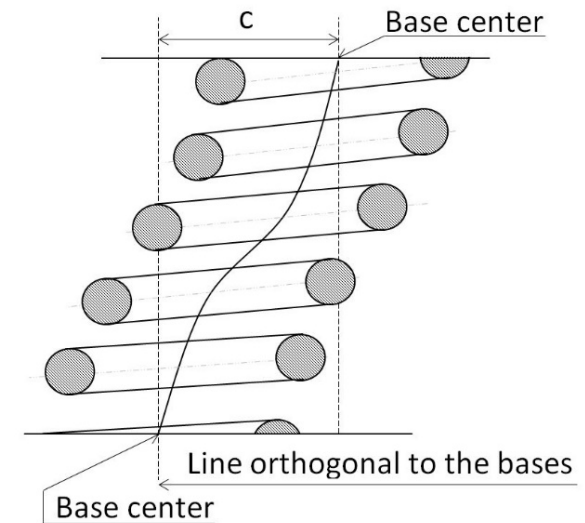

C3.f Task 3.6: Development of a traceability chain for multicomponent forces and moments

Transducers:

- INRIM: 2 MN monolithic strain cylinder (6-components)
- INRIM: 30 N integrated sensor (6-components)
- INRIM: 300 kN hexapode (6-components)
- INRIM: 5 MN hexapode (6-components)
- INRIM: 100 kN multi-sensor (6-components)
- INRIM: 500 kN multi-sensor (6-components)

INRIM: 2 MN monolithic strain cylinder (6-components)

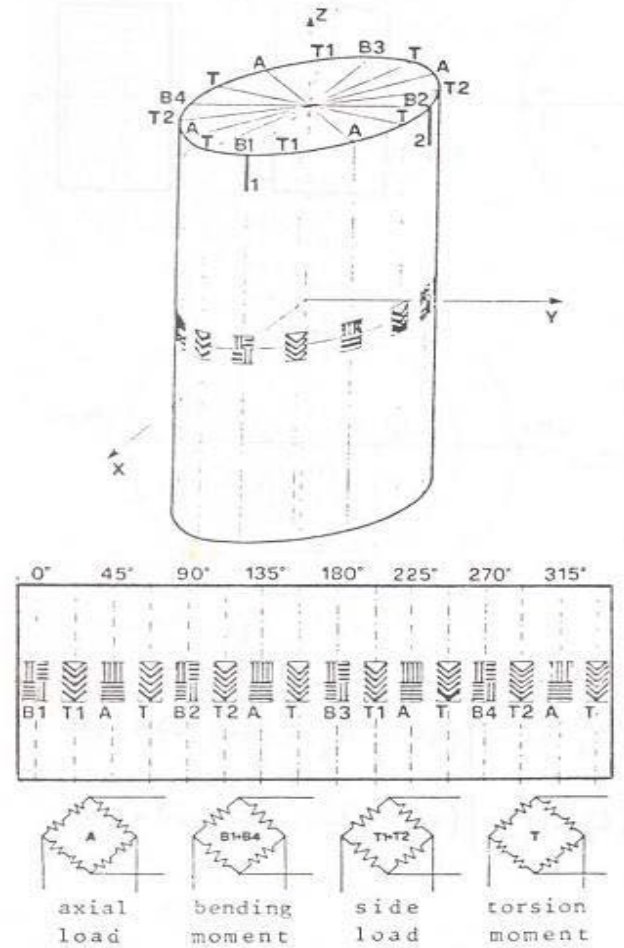

INRIM: 30 N integrated sensor (6-components)

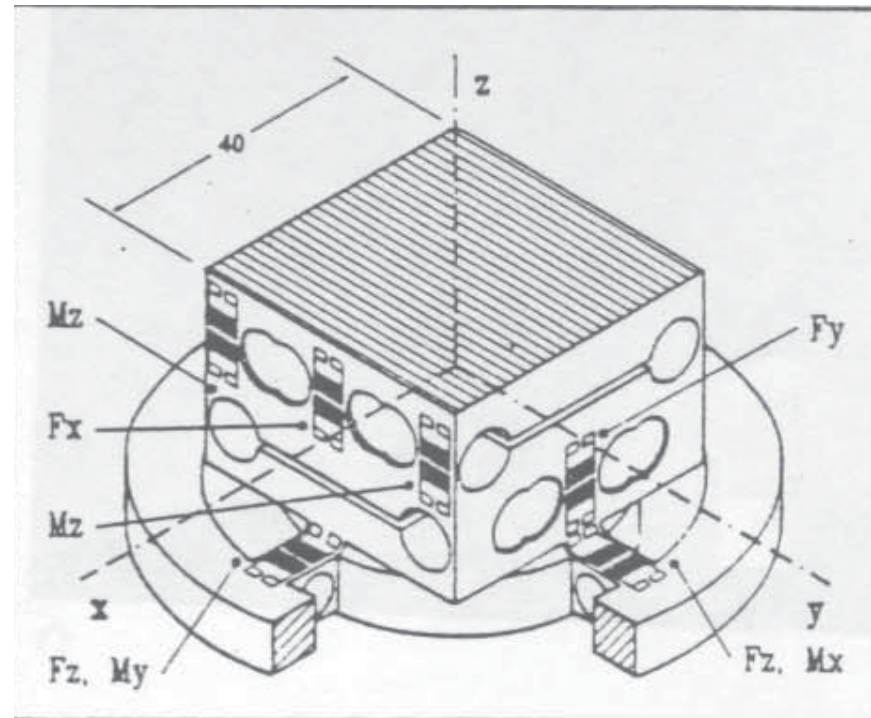

INRIM: 400 kN and 5 MN hexapode (6-components)

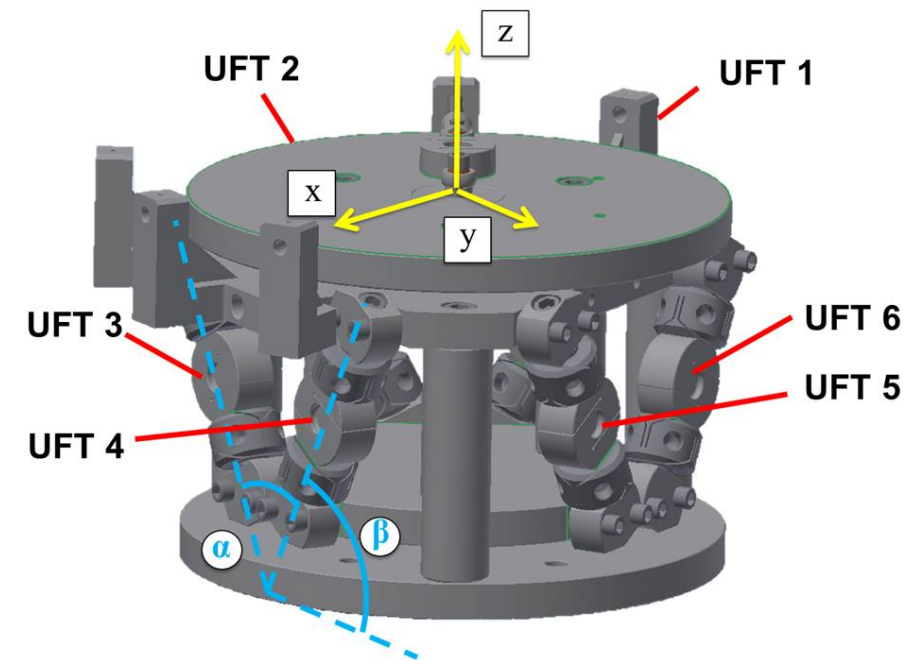
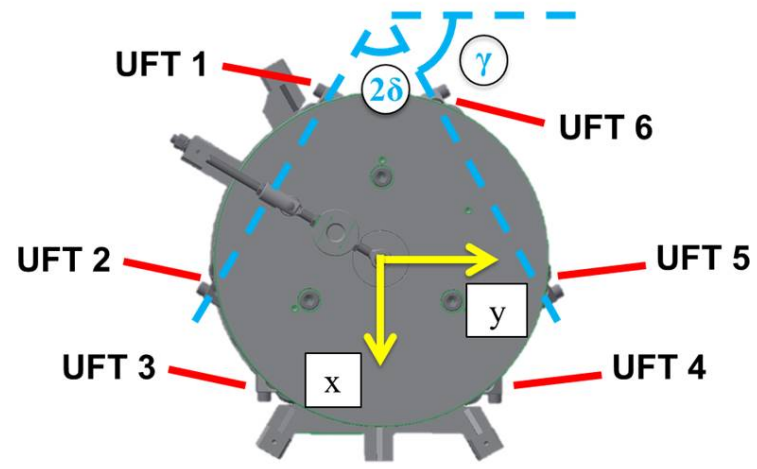
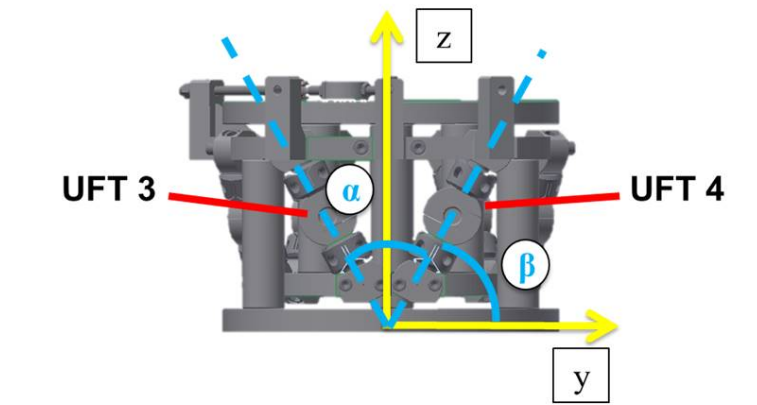
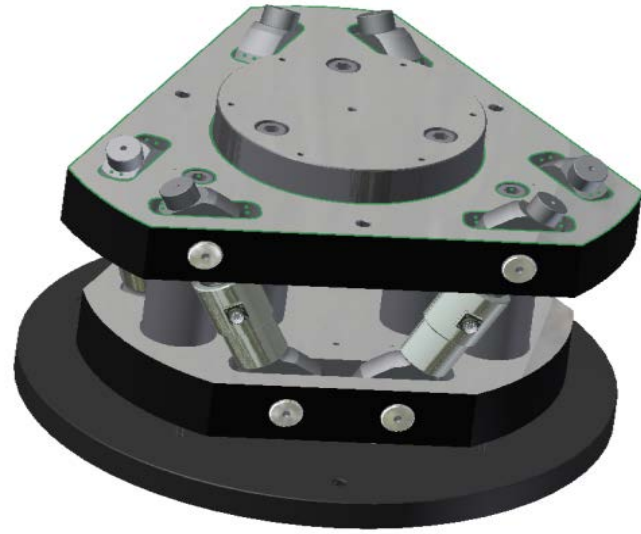

INRIM: 100 kN and 500 kN multi-sensor (6-components)

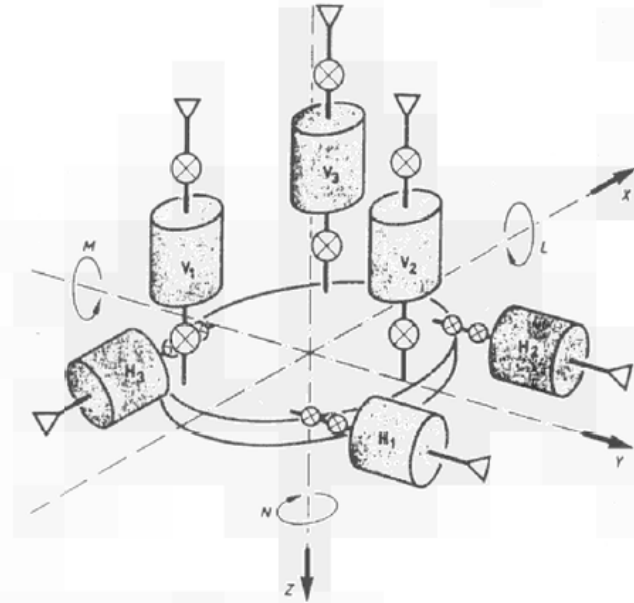

C3.f Task 3.6: Development of a traceability chain for multicomponent forces and moments

Calibration systems:

- INRiM: deadweight with:
 - dead weights with independent lateral force and moment application (100 kN)
 - dead weight with tilted planes (1 MN)
 - dead weight with rotating tables (500 N)

Calibration facilities: dead weights with independent lateral force and moment application (100 / 1 / 1) kN



Calibration facilities: dead weight with tilted planes (1 MN)

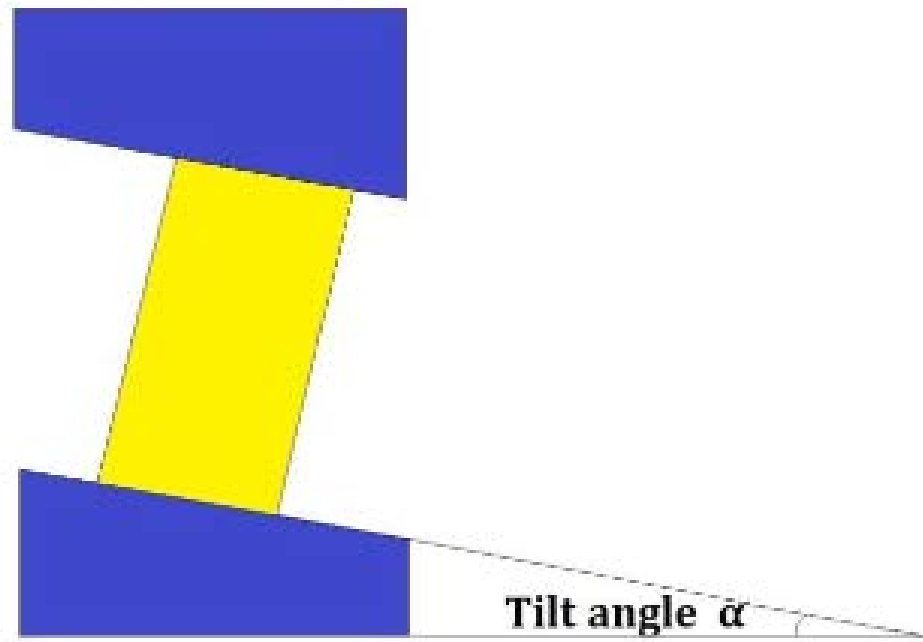
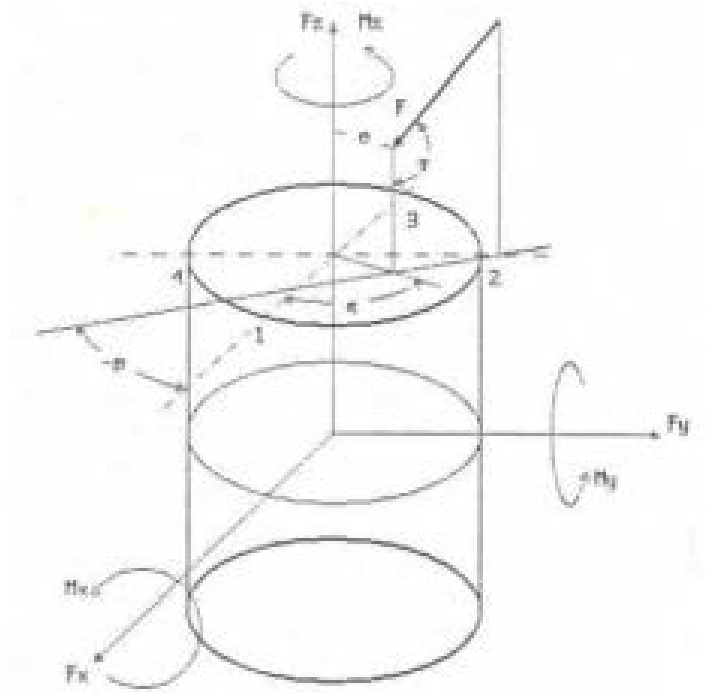

Calibration facilities: dead weight with rotating tables (500 N)

