



ISTITUTO NAZIONALE DI RICERCA METROLOGICA Repository Istituzionale

Automatic DC voltage precision resistive divider with ratios between 10:1 and 107:1

This is the author's accepted version of the contribution published as:

Original

Automatic DC voltage precision resistive divider with ratios between 10:1 and 107:1 / Galliana, Flavio; Cerri, Roberto; Corona, Davide. - In: MEASUREMENT. - ISSN 0263-2241. - 183:(2021), p. 109865. [10.1016/j.measurement.2021.109865]

Availability:

This version is available at: 11696/70690 since: 2021-07-26T10:39:31Z

Publisher:

Elsevier

Published

DOI:10.1016/j.measurement.2021.109865

Terms of use:

This article is made available under terms and conditions as specified in the corresponding bibliographic description in the repository

Publisher copyright

(Article begins on next page)

ABSTRACT

At INRIM a DC Voltage precision resistive divider performing decade ratios from 10:1 to 10^7 :1 was built. It can be automatically calibrated with a top-class calibrator and a precision multimeter calibrated in terms of deviation from linearity. It is made up of 90 k Ω , 9 k Ω , 900 Ω , 90 Ω , 9 Ω , 0.9 Ω , 90 m Ω and 10 m Ω bulk metal foil resistors connected in series, in four-terminal configuration. Peculiarities of the calibration method of the divider are: the evaluation of the DMM input impedance to correct its readings minimizing the load error and a solution to reduce the emfs effect of the relays. These operations are made during the calibration of the divider. The calibration and use uncertainties of the divider span respectively from 6.1×10^{-7} to 5.9×10^{-4} and from 6.7×10^{-7} to 6.5×10^{-4} . The project is transferable to secondary laboratories in the framework of the INRIM knowledge transfer task.

Key words: DC Voltage divider; resistive divider; voltage ratio; measurement uncertainty; temperature dependence; short-term stability; use uncertainties multimeter; calibrator.

1. INTRODUCTION

Due to their high accuracy, voltage dividers are used for the realization of the DC voltage scale for which the Calibration Measurement Capabilities (CMCs) of National metrology institutes (NMIs) usually span from 1 mV up to few thousands V. No NMI or laboratory, although operating below 1mV, participated at international comparisons to check CMCs below 1 mV. NMIs and high-level laboratories have used in the past manual type dividers [1, 2] as Ratio Standards for the traceability of DC Voltage and for calibration of high accuracy instruments as Digital Multi Meters (DMMs) and calibrators. For the same task, at the National Institute of Metrological Research (INRIM) is used also an automated fixed-ratio divider [3]. Guarded dividers were realized for precision DC voltage calibrations [4, 5] also at high voltages [6–10] while an interesting technique to determine the voltage ratios in self-calibrating dividers was developed at SPRING Singapore [11]. High precision binary Voltage dividers, based on the Cutkosky principle [12, 13], are already commercially available, but at high costs. Our divider, instead is a not-commercial precision one made up by components easy to find and its calibration setup involves

instruments usually available in electrical calibration laboratories. On the other hand, as the nanotechnologies, medical and scientific applications require measurements of very low voltage, the need of our realization has been further stimulated. Unfortunately, nanovoltmeters are often used without calibration only relying on their manufacturers' specifications. In the best NMIs, nanovoltmeters are calibrated vs. the Josephson effect (JVS) [14], an expensive and time-consuming procedure. NMIs and laboratories without JVS need alternative methods. In [15–19] interesting solutions to calibrate sources and meters, also at low voltages, with easily available standards, are proposed. The construction of the INRIM divider has been part of the INRIM technology transfer task. The aim was the realization of a standard to employ, after its characterization, in a future measurement setup for the calibration of nanovoltmeters. With such setup, the INRIM CMCs for DC Voltage could be extended to lower values than current ones. The divider therefore is not a mid or long-term standard, but a transfer standard to be calibrated before its use in a setup for calibration of other instruments. The automation has been made to facilitate and expedite the divider calibration. In the past instead, technicians had to calibrate manually the dividers before using them for other scopes. In addition, the divider project is transferable to NMIs without JVS and to secondary laboratories.

2. DIVIDER DESCRIPTION

The divider consists of seven sections. (Fig.1). It is made up by 90 k Ω , 9 k Ω , 900 Ω , 90 Ω , 9 Ω , 0.9 Ω , 90 m Ω and 10 m Ω precision metal-foil Vishay high stability resistors built on our request. These resistors are connected in series in four terminal configuration. The resistance values are the highest possible to carry the desired current.

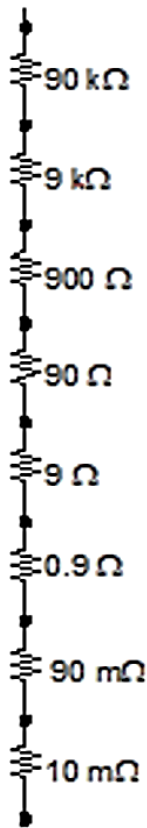

Fig. 1. Divider scheme.

The resistors were soldered on double width copper-plated tracks to comply with the kelvin connection technique. Although the board is covered by a protective layer to increase its lifetime, golden tracks and micro millings made in critical points allow to obtain suitably high insulation values between the tracks for our needs. These insulations are higher than those achievable with other methods as photoengraving or galvanic treatment. The welds were made with tin and specific flux for low emfs. Fig. 2 shows the electrical scheme of the divider with the relays to connect the resistors to the calibrator and to the DMM for the automatic calibration of the divider. This calibration is carried on in about one hour. The involved DMM takes advantage of its excellent linearity to improve the uncertainty of the calibration process. The used bistable relays (TX-S2-L-4,5) have contact resistance of few $m\Omega$ as they are equipped with silver/gold contacts with thermo-electromotive forces (emfs) of about 40 nV. The activation of the relays is made by AC Voltage coupling of the coils sending them a single pulse. This minimize the noises due to the self-heating of the relays or to their excitation and maintenance voltage. Therefore, during the measurements, there is no voltage on the

relays coils. The relays are monitored by the software to detect any anomalies.

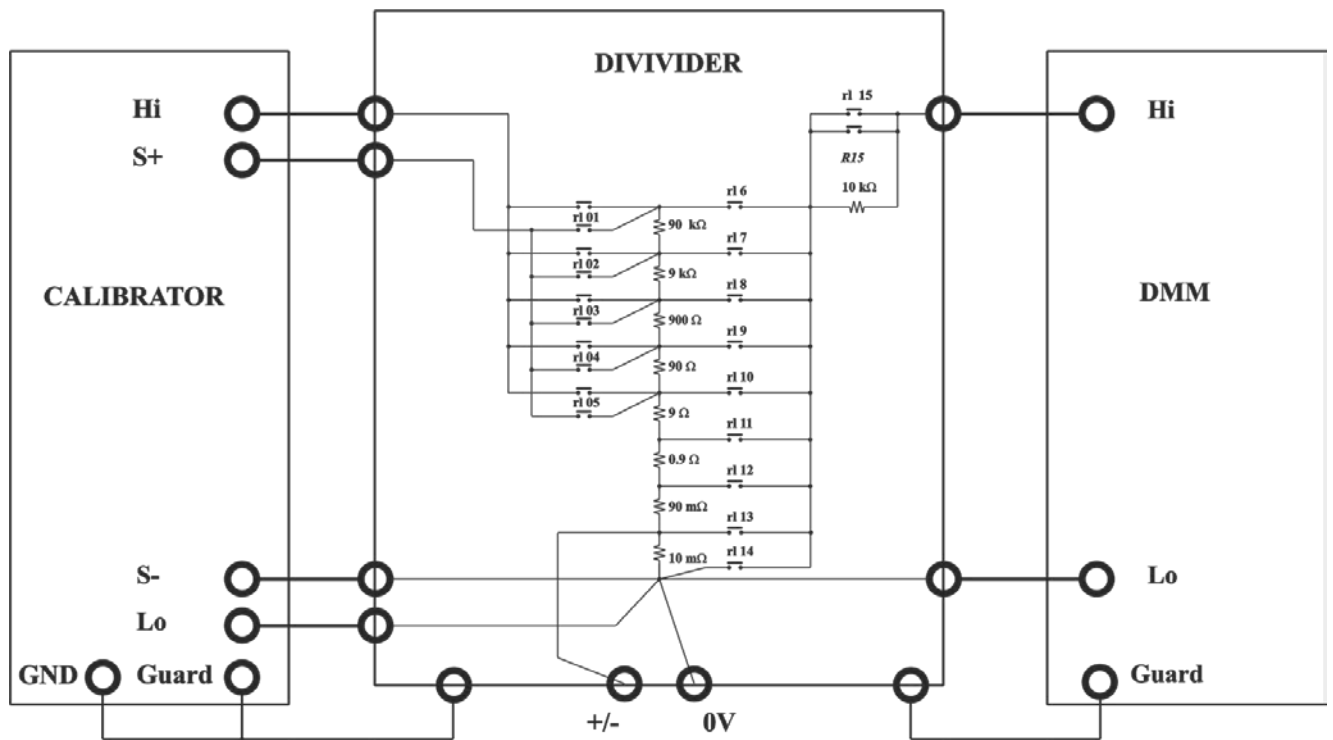

Fig. 2. Divider electrical scheme with the relays to connect the resistors to the calibrator and to the DMM for the divider calibration.

Fig. 3 shows the parts of the divider, whose resistors were inserted into the holes of a milled copper box to minimize electrical and thermal noises (Figs. 3 a, c). A 1 cm thick external aluminium case, (Figs. 3c, d), further increases the thermal stability due to its mass. A thermal sensor monitors the resistors temperature. The connections of the relays with the resistors are very short to reduce parasitic resistances.



Fig. 3a.

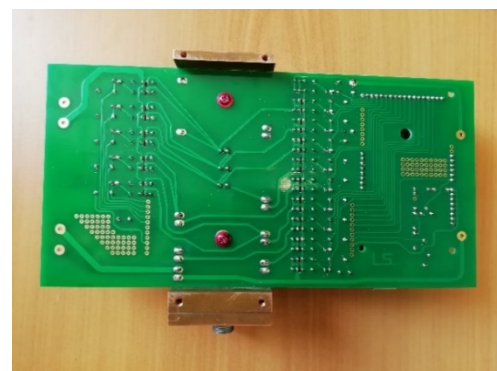

Fig. 3b.

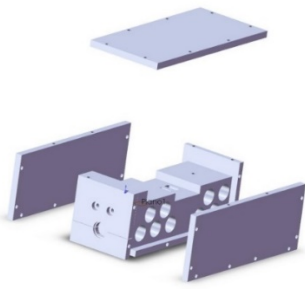

Fig. 3c.

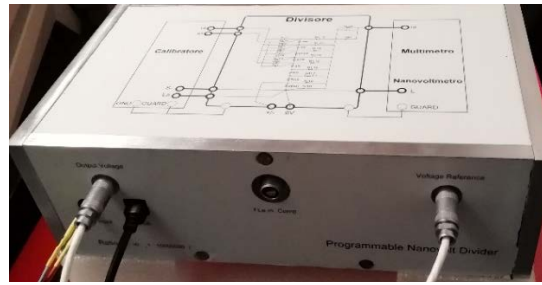

Fig. 3d.

Fig. 3. Images of the divider parts a) Copper box, Arduino board, resistors and relays b) Printed circuit board bottom view c) Cross-section of the mechanical components d) External view with the 1 cm thick aluminium case. Fig. 3c does not show yet the holes for the connectors of the external case as these were made after this draw.

2.1 Voltage limits

The voltages applied to divider sections are 100 mV, 1 V and 10 V. The voltage limits to apply at the input of each section are:

- Sections with input resistors of 90 k Ω and 9 k Ω : 10 V;
- Sections with input resistors of 900 Ω and 90 Ω : 1 V;
- Sections with input resistors 9 Ω , 0.9 Ω and 90 m Ω : 100 mV.

These voltages are chosen to avoid to exceed the maximum current limits of the calibrator [20] in DC Voltage. High power resistors were chosen avoid heat dissipation during the calibration of the divider as the applied power on the resistors is lower than their power limits.

2.2 Hardware - software interface

The Arduino Mega2650 board of the divider can be controlled in the same way of other instruments. The driver protocol defines which relay to activate/deactivate according to the command received on the serial port. The relays are switched through the digital outputs of the Mega 2650 board. A command for the measurement of the temperature was added. Once received the command, the board performs a voltage reading (analog input) and transmits the read value through the serial port. The temperature value is obtained by implementing an algorithm in VB.Net code converting the read voltage. In Fig. 4, the architecture of the control program of the divider and of its calibration setup is shown.

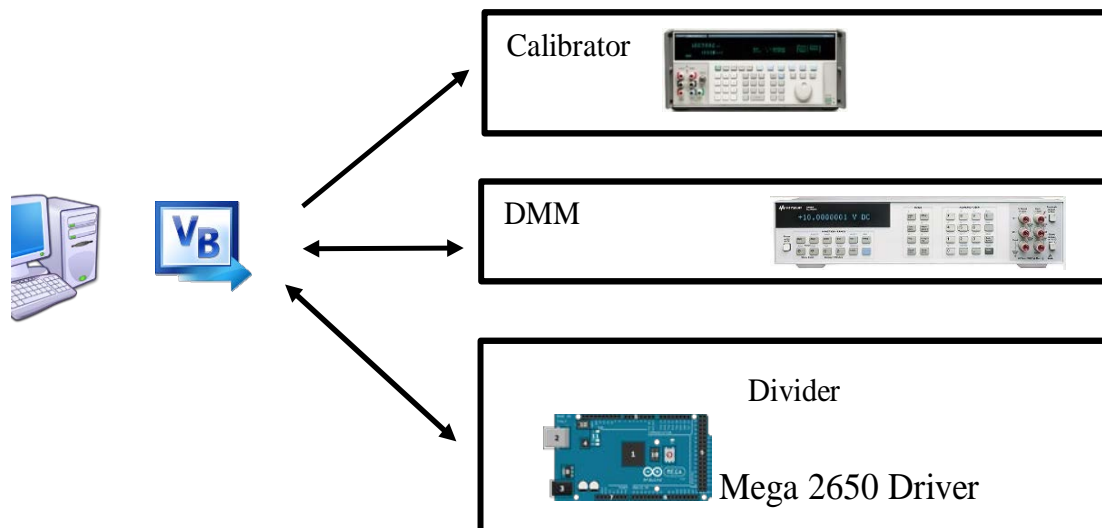

Fig. 4 Architecture of the control program of the divider and of its calibration setup.

The application in VB.net manages the three instruments during the measurement saving the acquired data on a file. The code consists in reading a two-dimension matrix on which the steps sequence is reported by means of tokens. The routines of setting, acquisition and stand-by of the three instruments correspond respectively to each token. For the evaluation of the DMM impedance, a software procedure implementing the steps of paragraph 5.2 was also added. The choice of the Arduino board was due to:

- Hardware robustness. Arduino devices withstand a lot of work cycles;
- Versatility. The Arduino board has a wide number of channels and facilities for any additional option;
- Open-source code; the easy use of the board allows interfacing it with any hardware environment;
- Easy availability.

3. DIVIDER CALIBRATION

Interesting setups for calibration of DC Voltage dividers were developed at Justervesenet [21] and at NMIJ [22]. The calibration of the INRIM divider, allowing to update its ratios values, is made by means of the measurement setup of Fig. 2 involving the calibrator [20], as high stability

DC voltage generator and the DMM [23], calibrated in terms of its deviation from linearity [24, 25] (see paragraph 5). In Fig. 5, a photo of the measurement setup is shown.

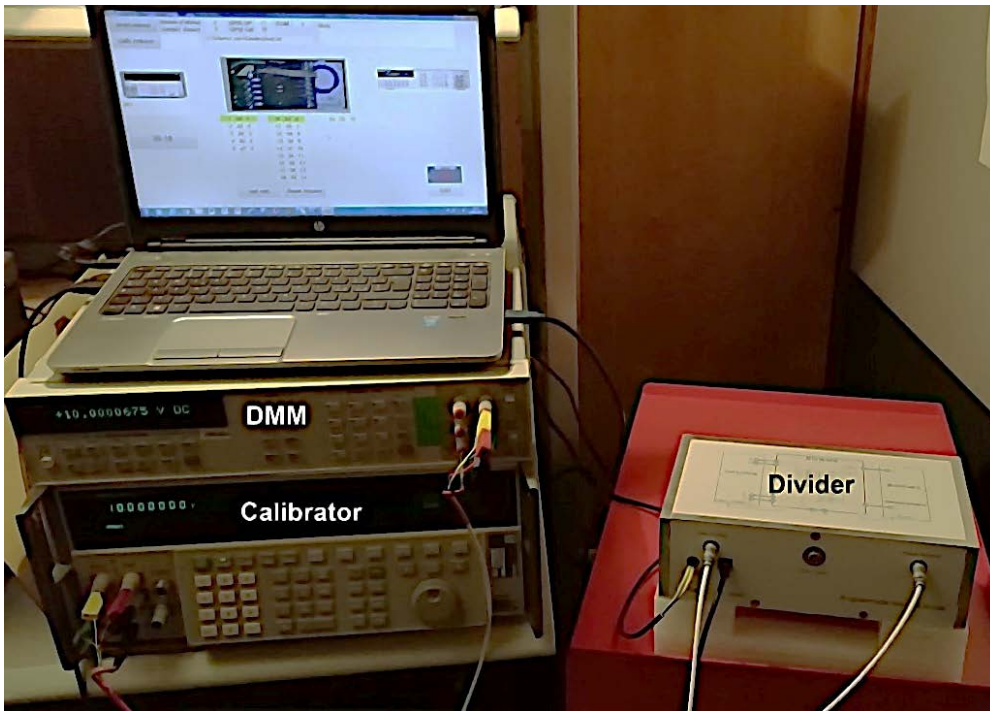

Fig. 5. Photo of the measurement setup to calibrate the INRIM divider.

The divider calibration is carried on by applying a DC Voltage by the calibrator, set with external senses, to the input resistor of a section of the divider at a time. The DMM measures the voltage between this resistor and the ground. Then, leaving unchanged the supplying point and the voltage value, the DMM measures, on the same range, the voltage on the input resistor of the lower section. By applying in cascade this technique from the first to the last section, the ratio values from 10:1 to 10^7 :1 are obtained.

For example, let's consider the calibration of the first divider section with a 90 k Ω input resistor (100 k Ω to ground). A + 10 V voltage (V_H) is applied to this resistor

Then, leaving unchanged the voltage application point, the DMM measures the output voltage V_L on the 9 k Ω resistor (10 k Ω to ground) $L_{VL} \cong 1$ V on the same range (Fig. 6).

and measured with the DMM **Fig. 6.** Voltages to be measured on the 10 V range (L_{VH}) to calibrate the first divider section.

The same procedure is repeated at -10 V to minimize the emfs effects. The procedure includes, before each section change and before the polarities reversal, the evaluation of the zeroes to be added to the subsequent DMM readings. The calibration of the other sections is made in the same way only moving the voltage application point to the lower sections (one at a time). Table 1 shows the resistors where V_H is applied and where L_{VH} and L_{VL} are measured in the calibration of the sections of the divider. The unknown ratios are given meaning the values at both polarities from:

$$R = \frac{L_{VH}}{L_{VL}} \quad (1)$$

Where $R \cong 10$ is the ratio, while L_{VH} and L_{VL} are the mean DMM readings in both polarities. In Table 1 the involved resistors, voltages and DMM ranges, are reported.

Table 1

Resistors, voltages and DMM ranges for the calibration of the INRIM divider.

| Section | Overall ratio | Resistor to apply V_H | Resistor to measure V_L | L_{VH} (V) | L_{VL} (V) | DMM range (V) |
|---------|--------------------|-------------------------|---------------------------|------------------|------------------|---------------|
| 1 | 10:1 | 90 k Ω | 9 k Ω | 10 | 1 | 10 |
| 2 | 100:1 | 9 k Ω | 0.9 k Ω | 10 | 1 | 10 |
| 3 | 1000:1 | 900 Ω | 90 Ω | 1 | 0.1 | 1 |
| 4 | 10 ⁴ :1 | 90 Ω | 9 Ω | 1 | 0.1 | 1 |
| 5 | 10 ⁵ :1 | 9 Ω | 0.9 Ω | 0.1 | 0.01 | 0.1 |
| 6 | 10 ⁶ :1 | 9 Ω ¹ | 90 m Ω | 0.01 | 10 ⁻³ | 0.1 |
| 7 | 10 ⁷ :1 | 9 Ω ² | 10 m Ω | 10 ⁻³ | 10 ⁻⁴ | 0.1 |

¹ V_H is applied on the 9 Ω resistor to avoid over load on the calibrator, but L_{VH} is measured on the 900 m Ω resistor.

² V_H is applied on the 9 Ω resistor to avoid over load on the calibrator, but L_{VH} is measured on the 90 m Ω resistor.

4. DIVIDER CHARACTERIZATION

4.1 Temperature dependence

In Figs. 7a),...,g) the temperature dependence of the ratios of the divider is shown while in Table 2 the temperature coefficient (TCR) of the divider is reported for each ratio. The measurements were carried out placing the divider in a high stability air-bath at (20.0, 21.5, 23.0, 24.5 and 26.0) °C.

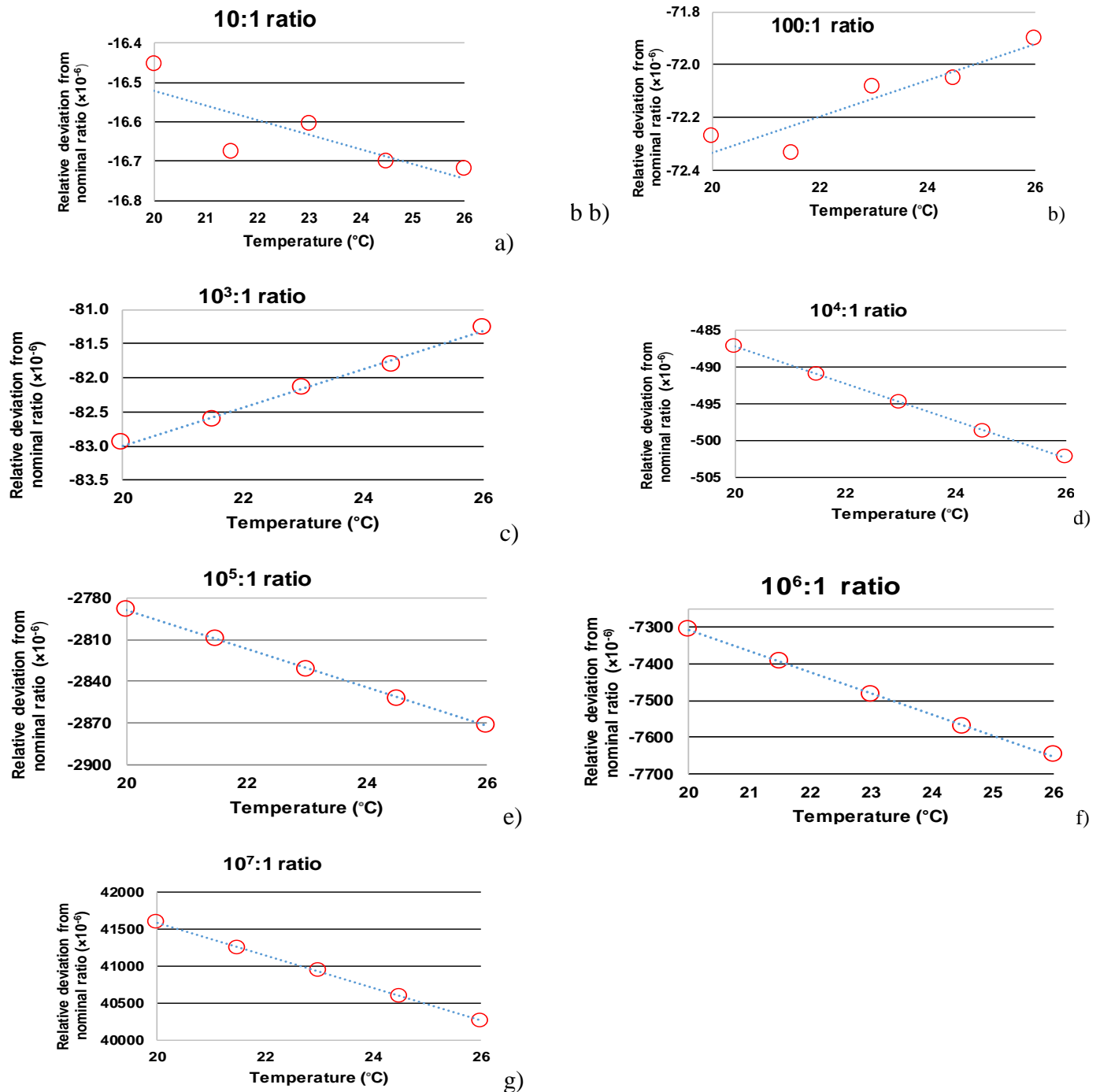

Fig. 7 Temperature dependence of the divider in ratio a) 10:1, b) 100:1, c) 10^3 :1, d) 10^4 :1, e) 10^5 :1, f) 10^6 :1 g) 10^7 :1.

The obtained results show a substantial independence of the 10:1 and 100:1 ratios vs. temperature while in the other ratios the linear dependence vs. temperature is anyway satisfactory as it does not exceed the calibration uncertainties of the corresponding sections of the divider. In fact, the divider has to be used in laboratories where the temperature is normally maintained at (23 ± 1) °C. The dependence vs. temperature is presumably due to the not-zero temperature coefficient of the resistors of the divider, especially of those with the lowest values. This affects higher ratios, justifying the increase of their TCR (Table 2). For example, in the 10^7 :1 ratio, a change of ± 3 °C induces a ratio change of $\pm 0.7 \times 10^{-3}$ vs. the value at 23 °C. This characterization allows to correct the ratios values if the divider is used in the complete evaluated temperature range. Ratio values are sometimes different from those of the following drift evaluation (in particular for higher ratios) as, for the evaluation of the dependence vs. temperature, longer cables were used to connect the divider setup to the air-bath, causing presumably a measurement error³. This error does not compromise anyway a correct evaluation of the dependence of the divider vs. temperature.

Table 2.
TCR of the ratios of the divider.

| Ratios | TCR ($\times 10^{-6}/^{\circ}\text{C}$) |
|-----------|---|
| 10:1 | -0.04 |
| 100:1 | 0.1 |
| 1000:1 | 0.3 |
| 10^4 :1 | -2.5 |
| 10^5 :1 | - 13.9 |
| 10^6 :1 | - 57.2 |
| 10^7 :1 | -221.1 |

³ These cables were used only for this temperature characterization to reach the air bath in which the divider was placed. They are not used in the ordinary measurement setup. The cables resistance in such case is negligible as the calibrator is set with external senses and the measurement is made in four terminals configuration.

4.2 Short-term drift (5 days) of the divider ratios values

The role of the divider is not that of a mid, long-term standard, but of a transfer standard to be calibrated before its use for calibration of other instruments. Anyway the short-term stability of the divider ratio was evaluated. In Figs. 8a) ... g), the short-time dependence of the ratios of the divider is shown. In particular, the focus is on their 5-days drift.

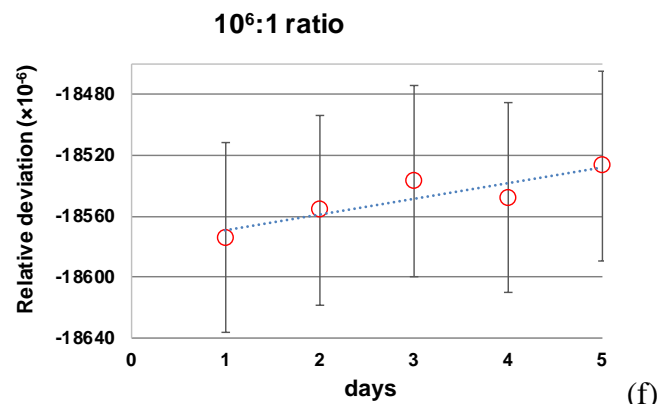
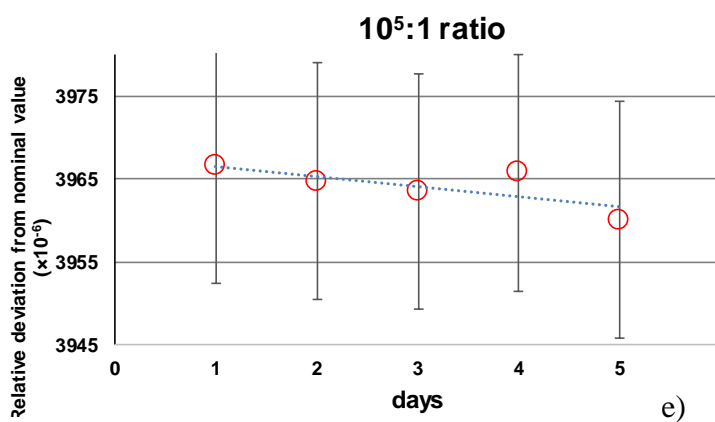
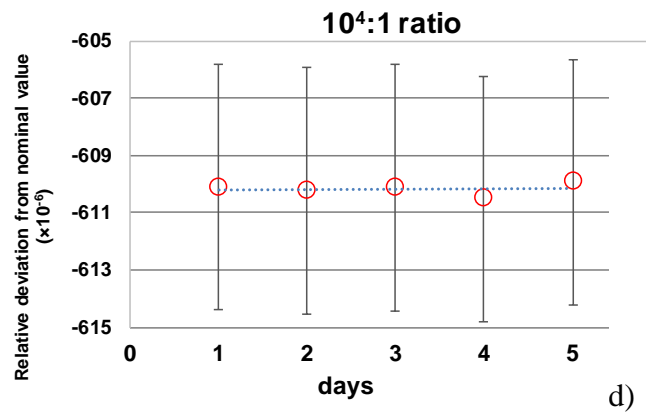
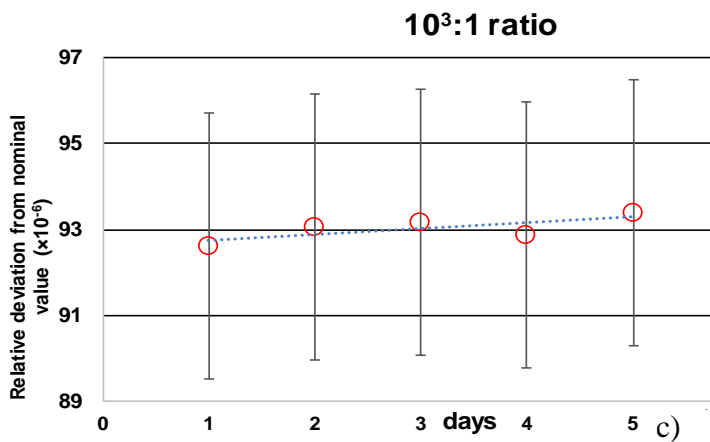
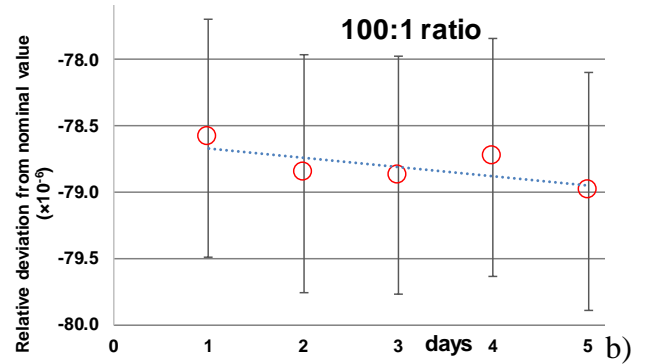
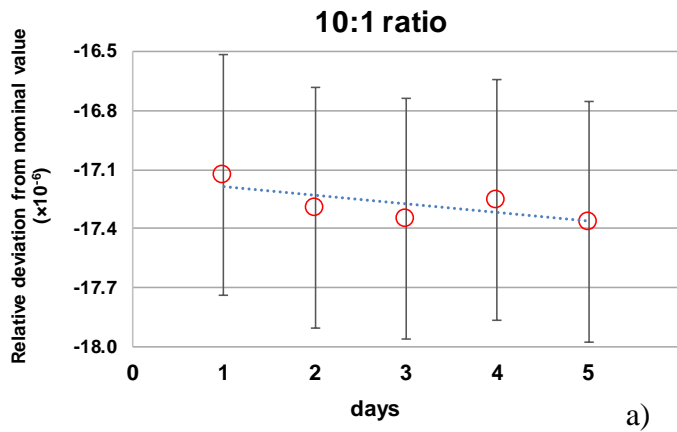

g)

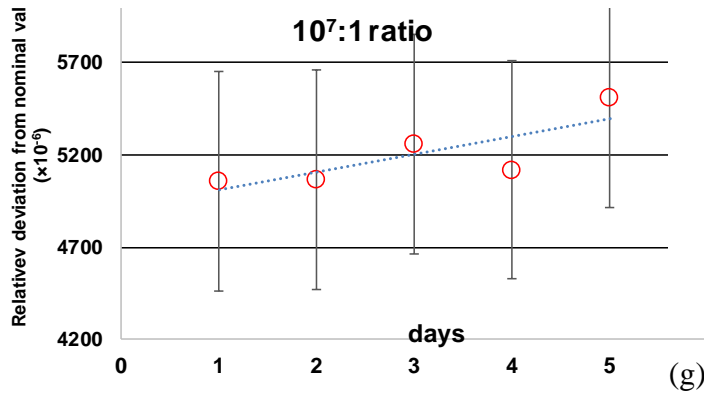

Fig. 8. Divider short-term (5 days) drift in ratio a) 10:1, b) 100:1, c) 10³:1, d) 10⁴:1, e) 10⁵:1, f) 10⁶:1 g) 10⁷:1. The uncertainty bars corresponds to the expanded calibration uncertainties.

The ratios from 10:1 to 10⁴:1 show a negligible drift vs. time while in the last three ratios the drift is anyway satisfactory as it does not exceed the calibration uncertainties of the corresponding sections of the divider. This drift is presumably due to the short term instability of the resistors of the divider, of the calibrator and of the DMM. The evaluation of the short-time drift of the divider allows to correct the ratio values of the divider in the first days after calibration and helps a laboratory to decide, according to its measurement procedures, if to repeat the calibration of the divider before using it for calibration of other instruments. For example, if a laboratory needs that the 10⁷:1 ratio deviation from to its calibrated value is less than 0.3×10⁻³, it can use the divider without re-calibration within four days from its calibration, otherwise it has to be recalibrated. This characterization of the divider is useful as it can be used as travelling standard for interlaboratory comparisons (ILCs) [26] among laboratories operating in DC Voltage ratio measurements. The evaluation of the temperature dependence instead allows to correct the measurements on the divider of the participants to an ILC at a reference temperature. Table 3 shows the short-term stability of the ratios of the divider.

Table 3.

Short-term stability of the ratios of the divider.

| Ratios | (×10 ⁻⁶ /day) |
|--------------------|--------------------------|
| 10:1 | -0.04 |
| 100:1 | -0.07 |
| 10 ³ :1 | 0.13 |
| 10 ⁴ :1 | 0.004 |
| 10 ⁵ :1 | -1.2 |
| 10 ⁶ :1 | 10.3 |
| 10 ⁷ :1 | 109.9 |

5. DMM CHARACTERIZATION FOR ITS USE IN THE DIVIDER CALIBRATION

The DMM used for the calibration of the divider was previously calibrated in terms of deviation from linearity by direct comparison vs. JVS in the 10 V, 1 V and 100 mV ranges. This kind of calibration assures that the DMM behaviour in specific ranges comply with the linearity specifications of the manufacturer. This characterization of the DMM and the fast calibration of the divider allow to use the linearity feature of the DMM in the measurements for the calibration of the divider. The uncertainties of these measurements, besides the measurements noise (repeatability), are due to the calibration of the DMM in terms of deviation from linearity in the 10 V, 1 V and 100 mV ranges or due to the Transfer Accuracy/linearity specifications of the DMM in the other measurement points. These uncertainties are both much smaller than the Accuracy specifications of the DMM. *Conditio sine qua non* of this criterion is that the measurement of the voltages V_H and V_L is carried out in the same DMM range to use the DMM linearity within the range. This is a calibration in linearity (i.e. using the DMM linearity feature). Without the DMM calibration in terms of deviation from linearity, the measurements should be made in two different ranges, as 10 V and 1 V ranges respectively for V_H and V_L of the first section. This is a calibration in gain (i.e. using the DMM gain feature) whose uncertainty corresponds to the DMM accuracy specifications (besides the measurements noise) leading to an overall larger uncertainty. The deviation from linearity of the DMM in the 10 V and 1 V ranges is shown in Fig. 9 and 10 where the bullets represent the linear fit of the measurements. The deviation from linearity feature does not change over time unless the DMM undergoes damages or repairs.

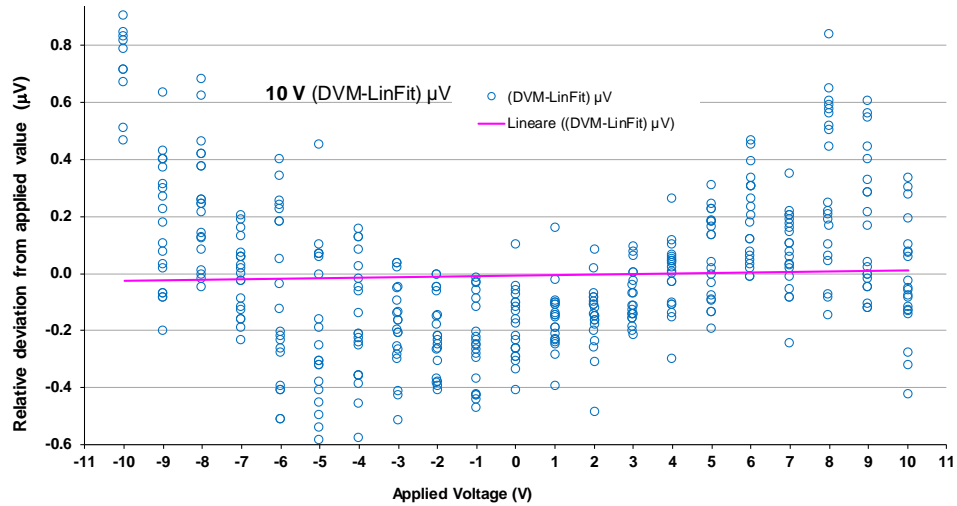

Fig. 9. Deviation from linearity of the selected DMM in the 10 V range.

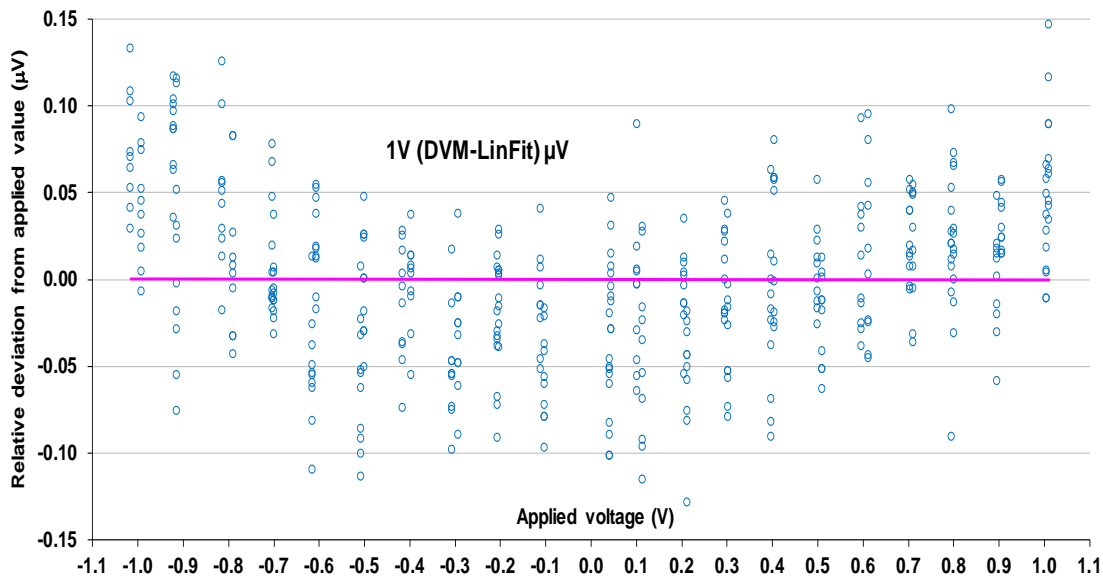

Fig. 10. Deviation from linearity of the selected DMM in the 1 V range.

Considering the results of the DMM calibration and the low measurement noise, the DMM readings can be acceptable without correction for their deviation from linearity when the DMM is used to calibrate the divider. Anyway as a precaution, an uncertainty component due to the DMM calibration in terms of deviation from linearity, has been added in the uncertainties budget.

5.1 Solutions to improve the measurement accuracy

During the calibration of the divider, the input impedance of the DMM to is also evaluated as this impedance varies for the different DMM ranges and according to the environmental conditions. This evaluation allows to correct the DMM readings minimizing the load effect due to the DMM in

particular for the calibration of the sections with higher output resistances. To reduce the effect of the emfs of the contact resistances of the relays, an additional relay (*rl* 14, fig.2) was inserted at the bottom of the resistors chain to short-circuit the DMM. This solution allows to perform a DMM voltage zeroing before the calibration of each section of the divider and before each polarity reversal. The voltages measured by the shorted DMM are algebraically added to the DMM measurements of each section. This is particularly important for the sections with the lowest output resistances. The obtained values for these measurements have been less than 50 nV. This solution further reduces the effect of the emfs compared to the only the polarity reversal.

5.2 Evaluation of the DMM input impedance and correction of the DMM readings

In Fig. 2 it is possible to see an auxiliary resistor R_{15} (10 k Ω) normally shorted by the relay *rl*₁₅. Let's consider a zoom of Fig. 2 around R_{15} in Fig. 11. The evaluation of the DMM input impedance is made starting from the 1 V measure of the first section, on the 9 k Ω resistor⁴. If R_{15} is shorted $V_{in} \cong V_{out}$ while, if R_{15} is enabled it is in series with the DMM forming an auxiliary voltage divider with the DMM input impedance.

⁴ The DMM impedance evaluation is not possible only when the DMM measures the voltage on the 90 k Ω resistor (100 k Ω to ground), as, in that case, all the divider resistance should be in parallel configuration with the calibrator output resistance $\cong 0$.

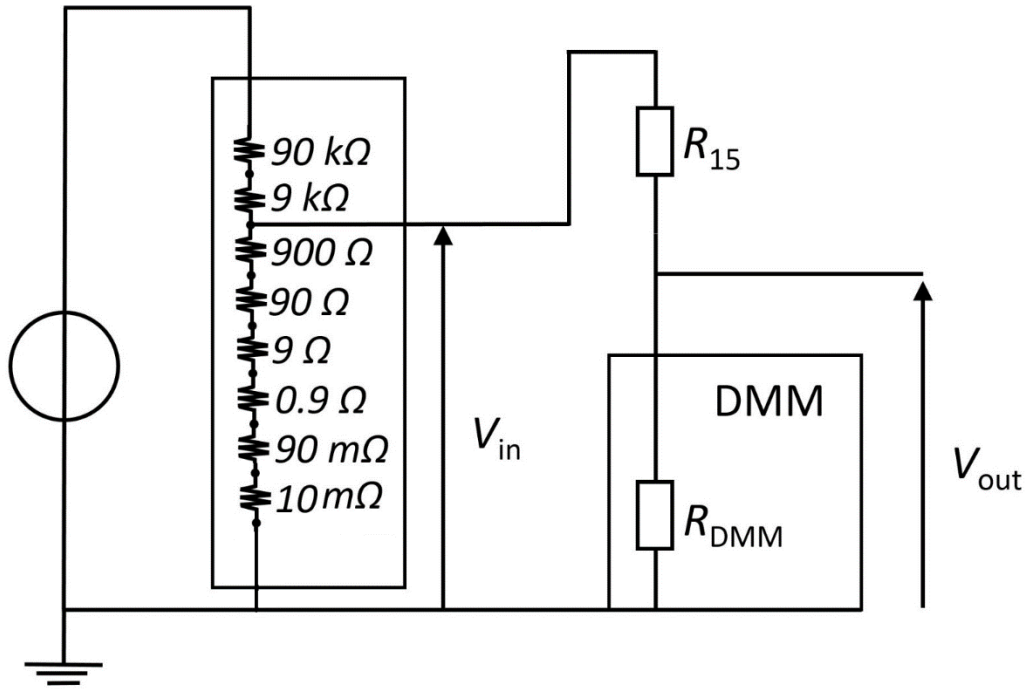

Fig. 11. Auxiliary voltage divider in the INRIM divider to evaluate the DMM impedance.

From the circuit of Fig. 11, enabling R_{15} , the following relations are valid:

$$I = \frac{V_{in}}{R_{DMM} + R_{15}} \quad (2)$$

$$V_{out} = R_{DMM} \frac{V_{in}}{R_{DMM} + R_{15}} \quad (3)$$

From which with easy steps it can be obtained:

$$R_{DMM} = R_{15} \frac{V_{out}}{V_{in} \left(1 - \frac{V_{out}}{V_{in}}\right)} \quad (4)$$

For example, R_{DMM} before the calibration of the first section of the divider, is evaluated averaging five measurements made according to (4).

Table 4.
Example of a DMM impedance measurement.

| V_{out} | V_{in} | R_{15} | R_{DMM} | R_{DMM} |
|-----------|-----------|----------|-----------|-----------|
| (V) | (V) | (kΩ) | (GΩ) | (GΩ) |
| 0.9999911 | 0.9999916 | 10 | 19.9998 | 19.9998 |

In table 3 V_{in} and V_{out} are the voltage values read by the calibrated DMM, assuring the traceability to the DC Voltage national standard. The calibrator instead is not calibrated acting as high stability DC Voltage generator. In table 4 R_{DMM} is evaluated with two alternative relations giving the same result. After the determination of R_{DMM} , R_{15} is shorted again. R_{DMM} is now in parallel with the output resistance of the section of the divider under measure. If the output resistance is 10 k Ω , this resistance in parallel with R_{DMM} is 9.9999934 k Ω , i.e. 6.6×10^{-7} lower than its actual value. The correction of the DMM readings at 10 V will be therefore an increase of voltage values read by the DMM of the same relative value.

6. MEASUREMENT UNCERTAINTIES

In Table 5, the standard uncertainties due to the temperature and drift effects on the divider are reported. The temperature components have been evaluated assuming the use of the divider at a temperature of (23 ± 0.1) °C. All these components have been obtained by means of a linear fit of the measured data.

Table 5.

Standard uncertainties of temperature (u_T) and drift at 5 days of the INRIM divider (u_{stab}).

| Ratios | $u_T (\times 10^{-7})$ | $u_{stab} (\times 10^{-6})$ |
|-----------|------------------------|-----------------------------|
| 10:1 | 0.02 | 0.1 |
| 100:1 | 0.0 | 0.1 |
| 1000:1 | 0.2 | 0.2 |
| 10^4 :1 | 1.5 | 0.2 |
| 10^5 :1 | 8.0 | 1.9 |
| 10^6 :1 | 33.0 | 13.8 |
| 10^7 :1 | 128 | 131.1 |

The uncertainty due to the drift effect has been obtained evaluating the difference from the maximum and the minimum relative deviation from the ratio nominal value among 5 days. This difference has been considered as a 2a interval of a rectangular distribution [27]. This smaller uncertainty has been considered as the ratio values can be corrected according to their 5 days-drift.

6.1 Calibration uncertainties

Let's consider the example in which a 10 V voltage is applied on the 90 k Ω input resistance of the first section of the divider. Table 6 shows the budget of the standard uncertainties, according to [27], for the calibration of this section while Table 7 lists the calibration standard uncertainties of all the sections. The uncertainties of the calibration of the DMM in terms of deviation from linearity are considered instead of their one-year accuracy specification.

Table 6.
INRIM divider first section calibration standard uncertainties.

| Component | Type | 1 δ ($\times 10^{-8}$) | ν |
|--|------|------------------------------------|------------------------|
| L_{VH} measurement noise | A | 0.7 | 29 |
| L_{VL} measurement noise | A | 1.2 | 29 |
| 10 V linearity calibration | B | Negl. | ∞ |
| 1 V linearity calibration | B | 19 | ∞ |
| Calibrator stability | B | 23 | ∞ |
| Emfs at 10 V | B | 0.2 | 50 |
| Emfs at 1 V | B | 0.2 | 50 |
| Load error correction at 10 V | B | 0.7 ⁵ | 50 |
| Load error correction at 1 V | B | 5.8 ⁶ | 50 |
| Contact resistances error correction at 10 V | B | 0.04 | 50 |
| Contact resistances_error correction at 1 V | B | 0.4 | 50 |
| Ratio Square Sum (RSS) | | 31 | $\nu_{eff} \cong 3469$ |

Where:

L_{VH} measurement and L_{VL} measurement noises are respectively the standard deviation of the mean of the DMM measurements at 10 V and at 1 V;

10 V linearity and 1 V linearity calibrations are respectively the uncertainties of the DMM calibration in terms of deviation from nominal value;

Calibrator stability is the short-time stability of the calibrator applying 10 V;

Emfs at 10 V, Emfs at 1 V are the uncertainties due to the emfs when the DMM measures respectively 10 V or 1 V;

Load error at 10 V and Load error corrections at 1 V are respectively the uncertainties of the corrected DMM measurements at 10 V and at 1 V for load effect;

⁵ This component was evaluated considering the input impedance of the involved DMM selected among the available DMMs [23] as it resulted the one with the highest impedance ($\cong 8.6 \times 10^{11} \Omega$).

Analogously, Contact resistances error at 10 V, Contact resistances error corrections at 1 V are respectively the uncertainties of the corrected DMM measurements at 10 V and at 1 V due to the emfs of the relays contact resistances.

With the evaluated effective no. of degrees of freedom, the expanded calibration uncertainties are obtained multiplying the standard ones by a coverage factor of 1.96.

Table 7.

INRIM divider calibration uncertainties of each section and of the overall ratios. Also in this case the expanded uncertainties are evaluated with a coverage factor $k \cong 1.96$.

| Section | $u_{sect} (\times 10^{-6})$ | Overall ratios | $u (\times 10^{-6})$ | $U (\times 10^{-6})$ |
|---------|-----------------------------|----------------|----------------------|----------------------|
| 1 | 0.31 | 10:1 | 0.31 | 0.61 |
| 2 | 0.31 | 100:1 | 0.43 | 0.9 |
| 3 | 1.5 | 1000:1 | 1.5 | 3.1 |
| 4 | 1.5 | 10^4 :1 | 2.1 | 4.3 |
| 5 | 6.8 | 10^5 :1 | 7.1 | 14.2 |
| 6 | 30 | 10^6 :1 | 31.2 | 62.4 |
| 7 | 295.4 | 10^7 :1 | 297.1 | 594.2 |

The uncertainties of the overall ratios have been evaluated taking into account a partial correlation ($r = 1.6 \times 10^{-4}$ for the first two sections) among the ratios measurement. r was calculated according to [28].

6.2 Validation of the calibration method

For a preliminary validation of the calibration method of the divider, the first three sections divider itself were also calibrated vs. a reference divider Datron 4902S with the measurement method described in [3], § 4 with approved CMC reported in the MRA⁶ database. The reference divider was in turn calibrated with a validated calibration system as INRIM participated with this method with satisfactory results to the CCEM-K8 comparison of DC Voltage Ratio [29]. The comparison results are reported in Fig. 12.

⁶ The CIPM Mutual Recognition Arrangement (CIPM MRA) is the framework through which National Metrology Institutes demonstrate the international equivalence of their measurement standards and of their calibration certificates. The outcomes of the Arrangement are the internationally recognized Calibration and Measurement Capabilities (CMCs) of the participating institutes.

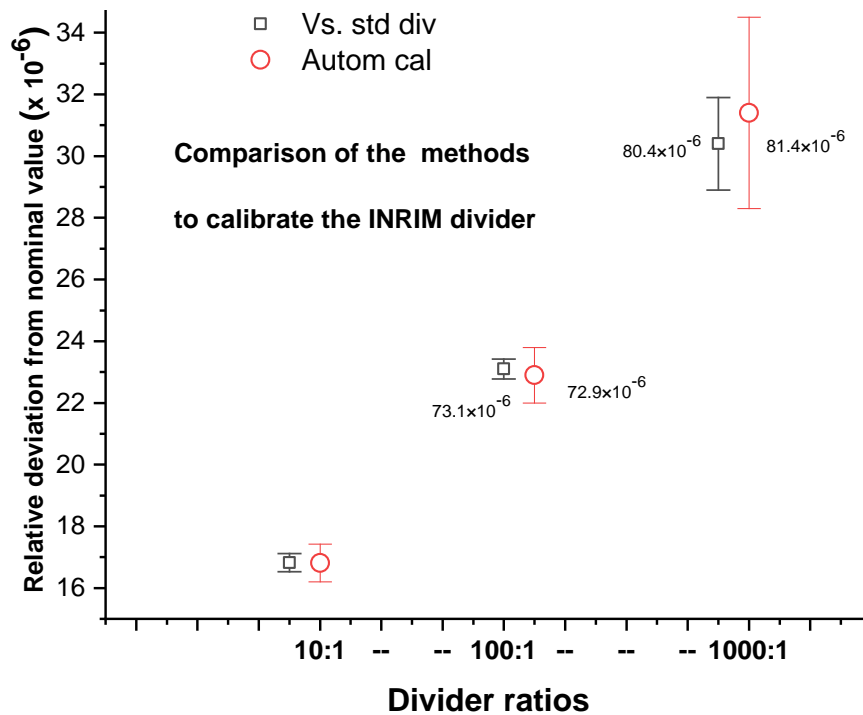

Fig. 12. Calibration values of the 10:1 100:1 and 1000:1 DC Voltage ratios of the INRIM divider obtained with the method of comparison with the INRIM standard divider and with the automatic method. The values for the 100:1 and 1000:1 ratios have been shifted in the graph to improve its readability. Real values are given near the measurement bullets. Their high deviation from nominal value is presumably due to the values of the resistors of the divider. The error bars represent the expanded uncertainties of the measurements with the two methods corresponding to a 95 % confidence level.

The agreement between the two methods in the ratios with the lowest uncertainty is satisfactory.

Unfortunately, the comparison for all ratios was not possible as the lead compensator of the measurement setup involving the reference divider cannot compensate higher ratios. A complete validation will be possible when a setup for calibration of nanovoltmeters involving the divider will be developed. This setup could be compared vs. the JVS.

6.3 Use uncertainties

The use uncertainties of the divider (Table 8) are those to take into account when it is used in a measurement system for the calibration of other instruments [30]. The use uncertainties are usually larger than the calibration ones as the divider could be used for example at a slightly different temperature with which it was calibrated or could be used not immediately after its calibration. The use uncertainties are therefore obtained as RSS of the uncertainties due to its calibration, temperature effect and short-term drift [27].

Table 8.

Use uncertainties of each section and of the overall ratios of the INRIM divider. Also in this case the expanded uncertainties are evaluated with a coverage factor $k \cong 1.96$.

| Overall ratios | $u_{cal} (\times 10^{-6})$ | $u_T (\times 10^{-6})$ | $u_{stab} (\times 10^{-6})$ | $u_{use} (\times 10^{-6})$ | $U_{use} (\times 10^{-6})$ |
|----------------|----------------------------|------------------------|-----------------------------|----------------------------|----------------------------|
| 10:1 | 0.31 | 0.002 | 0.1 | 0.34 | 0.67 |
| 100:1 | 0.43 | 0.00 | 0.1 | 0.45 | 0.9 |
| 1000:1 | 1.5 | 0.02 | 0.2 | 1.56 | 3.1 |
| 10^4 :1 | 2.1 | 0.1 | 0.2 | 2.15 | 4.3 |
| 10^5 :1 | 7.1 | 0.8 | 1.9 | 14.4 | 28.8 |
| 10^6 :1 | 31.2 | 3.3 | 13.8 | 64 | 128 |
| 10^7 :1 | 297 | 12.8 | 131 | 325 | 650 |

Analyzing the accuracy specifications of two high-performance commercially available nanovoltmeters, the divider use uncertainties are suitable to involve it in a measurement setup for calibration of nanovoltmeters from 1 μV to 10 V. In fact, the specifications of these nanovoltmeters, typically their one-year accuracies, are larger than the use uncertainties of the INRIM divider. Therefore, it is suitable to be involved in a future setup for calibration of these instruments, as the uncertainty of the standard must always be smaller than that of the device under calibration.

Conclusion

From the obtained results, the performance of the divider is satisfactory considering its short-term stability, temperature dependence, compatibility test and use uncertainties. Calibrating the divider as described in the paper, it can be used for the calibration of nanovoltmeters from 1 μV to 10 V. This is necessary as the divider must be used at the same voltages at which it is calibrated and characterized to take into account its use uncertainties. Nevertheless, if the divider is characterized, for example, by applying 1 V to the first four sections, it is possible to calibrate nanovoltmeters from 100 nV to 1 V and so on even for lower input voltages. On the other hand, characterizing the divider at voltages lower than 10 V or at not decade values, an increase of its uncertainties is possible. Main dividers reported in the references, although very effective, do not provide as many ratios as our divider. To obtain division ratios down to mV levels, the performance of our divider could be

compared with commercial self-calibrating binary dividers with similar uncertainties but available at high costs and with a totally different technology. At INRIM or in high level secondary laboratories the performance of our divider could be compared with the manually operating Fluke, 720 A Kelvin Varley voltage divider with a time consuming self-calibrating procedure instead of the quick automatic calibration of our divider. In addition, the 720A has a too high output resistance to be employed for calibration of nanovoltmeters. Future aims of this work will be the evaluation of the transport effect as the divider can be used as travelling standard for ILCs. For this role, it could be transported by car, by plane or by express couriers. When a circuit for nanovoltmeters calibration involving the divider will be set up, a comparison with JVS or a with another validated method among those reported in references could be planned.

References

- [1] Fluke Corporation, 752 A reference divider Instruction Manual, Rev. 1, 1984.
- [2] Fluke Corporation, 720 A Kelvin Varley voltage divider instruction Manual, Rev. 2, 1974.
- [3] F.Galliana, P.P. Capra R. Cerri, M. Lanzillotti, Automated precision DC voltage fixed ratios divider, *Measurement* 122, 2018 pp. 291–296.
- [4] Y. Sakamoto, T. Endo, H. Shao, S. Matsuzawa, Automated dc voltage divider to calibrate voltages up to 1 kV, in: *Prec. El. Measur. Conf. CPEM*, (2000) 363–364.
- [5] Tadashi Endo, Y. Sakamoto, T. Sakuraba, Y. Murayama, H. Yoshida, A. Odawara, Automated voltage divider to calibrate a 10-V output of Zener voltage standard, *IEEE Trans. Instrum. Meas.* 40 (2) (1991) 333– 336.
- [6] H.Hirayama ; M. Kobayashi, K. Murakami, T. Kato, 10-kV high-Accuracy dc voltage divider, *IEEE Trans. Instrum. Meas.* 23 (4) (1974) 314– 317.
- [7] Yi Li, Miyuru K. Ediriweera, F. S. Emms, A. Lohrasby, Development of precision DC high-voltage dividers, *IEEE Trans. Instrum. Meas.* 60 (7) (2001) 2211–2216.
- [8] R.B.D. Knight; P. Martin, A high voltage divider having an uncertainty of 5 p.p.m. at 100 kV, *IEEE Trans. Instrum. Meas.* 54 (5) (2005) 568–570.

- [9] N. Dragounova, Precision high-voltage dc dividers and their calibration, *IEEE Trans. Instrum. Meas.* 42 (2) (1993) 1911–1915.
- [10] A. Mereva, Ö. Kalenderli, The construction of a dc high voltage precision divider, *Journal of Electrostatics* 67 (5) (2009) 741–745.
- [11] Ling Xiang Liu, Sze Wey Chua, Determination of DC Voltage Ratio of a Self-Calibrating DC Voltage Divider, *IEEE Trans. Instrum. Meas.*, 54 (2) (2005) 571–575.
- [12] R. D. Cutkosky, A new switching technique for binary resistive dividers, *IEEE Trans. Instrum. Meas.*, IM-27 (4) (1978) 421–422.
- [13] S. Hoi Tsao, A 25-Bit Reference Resistive Voltage Divider, *IEEE Trans. Instrum. Meas.*, IM-36 (2), (1987) 285–290.
- [14] D. Georgakopoulos, I. Budovsky, S. Grady, and T. Hagen, Quantum Calibration System for Digital Voltmeters at Voltages from 10 nV to 1 kV, *IEEE Trans. Instrum. Meas.*, 62 (6), (2013) 1581–1586.
- [15] D. E Murray, C. Laurie, T. B. Lawson, Building-up the DC Voltage Scale for Sources and Meters, *Prec. El. Measur. Conf. CPEM* (2014) 138–139.
- [16] D. Aviles, E. Navarrete, DC voltage traceability to microvolt and nanovolt levels, *Prec. El. Measur. Conf. CPEM* (2018) 1–2.
- [17] B.O. Andersson, Murray Early, G. Eklund, O. Gunnarsson and K.I-E. Rydler, The reference step method for DC voltage at 1 mV and 10 mV, *Prec. El. Measur. Conf. CPEM* (2014) 520–521.
- [18] B.-O. Andersson, G. Eklund and T. Bergsten, Calibration of Gain Ratios on nV-meters with the Reference Step Method, 31th. *Prec. El. Measur. Conf. CPEM* (2018) 138–139.
- [19] M. D. Early, M. Šíra, B.O. Andersson, L. A. Christian, O. Gunnarsson, A Simple Build-Up Method for the DC Voltage Scale of a Source, *IEEE Trans. Instrum. Meas.*, 62 (6), (2013) 1600–1606.
- [20] Fluke Corporation, 5700A/5720A Series II Multi-function calibrator service manual, Rev. 1, 3/02, June 1996.

- [21] H. Slinde and K. Lind, Precision Setup and Method for Calibrating a DC Voltage Divider's Ratios from 10 V to 1000 V, *IEEE Trans. Instrum. Meas.* 52 (2) (2003) 461–464.
- [22] Y. Sakamoto and H. Fujiki, DC Voltage Divider Calibration System at NMIJ, *IEEE Trans. Instrum. Meas.* 52 (2) (2003) 465–468.
- [23] Agilent Technologies, 3458A multimeter - User's Guide, revision: B.01, March 2001.
- [24] A. Sosso and R. Cerri, Calibration of multimeters as voltage ratio standards, in *Prec. Elec. Conf. CPEM 2000*, Sydney, NSW, (Australia), 2000, pp. 375–376.
- [25] J. I. Giem, Sub-ppm linearity testing of a DMM using a Josephson junction array, *IEEE Trans. Instrum. Meas.*, 40 (2), (1991) 329–332.
- [26] F. Galliana, Measurement comparisons: A tool to guarantee the reliability of measurement systems and of high-tech industry, *IEEE. Instrum. Meas. Magazine* vol. 22 (2) (2019) 62-66.
- [27] JCGM 100:2008 Evaluation of measurement data - Guide to the expression of uncertainty in measurement First edition.
- [28] F. Galliana, M. Lanzillotti, Accurate comparison between INRIM and a secondary calibration laboratory using a top-class multifunction electrical calibrator, *Measurement* 103 (2017) 353–360.
- [29] G Marullo Reedt and R Cerri, Final report on key comparison CCEM-K8 (dc voltage ratio) *Metrologia* 40 0100.
- [30] W. Bich, F. Pennechi, On the in-use uncertainty of an instrument, in: P. Ciarlini, M. G. Cox, E. Filipe, F. Pavese, D. Richter (Eds), *Adv. Math. Comput. Tools in Metrology*, World Scientific, (2004) 59–169.