



ISTITUTO NAZIONALE DI RICERCA METROLOGICA Repository Istituzionale

Measuring light

This is the author's accepted version of the contribution published as:

Original

Measuring light / Brida, G.. - Course 196:(2017), pp. 345-356.

Availability:

This version is available at: 11696/57509 since: 2021-03-09T11:46:11Z

Publisher:

IOS PRESS

Published

DOI:

Terms of use:

This article is made available under terms and conditions as specified in the corresponding bibliographic description in the repository

Publisher copyright

(Article begins on next page)

Measuring light – Giorgio BRIDA (INRIM)

Summary – This paper is a review of the existing primary standards for the measurement of the optical radiation; blackbody, synchrotron radiation and electrical substitution radiometer. A summary of the recent and significant advances in this field with the carbon nanotube absorber in the electrical substitution radiometer and the development of the predictable quantum efficiency detector is described. Photon counting principles for the realization of the radiometric and photometric quantities are introduced and finally the route for the realization of the candela, the measurement of the luminous intensity, is depicted.

Introduction

Radiometry is the metrology domain devoted to electromagnetic radiation measurements, including visible light. In particular, photometry measures the visible light taking into account sensibility of optical human eye. Radiometry performs light measurements over the complete electromagnetic spectrum while photometry is limited to visible range, between 380 nm and 830 nm, where human eye is sensitive.

All radiometric quantities have a corresponding photometric quantity where power or energy are conveniently weighted by visible perception of the average human eye. The photometric quantity Luminous Intensity is one of the seven base units of the International System (SI); the corresponding measurement unit is the candela (cd). Photometry is essential to evaluate light sources and generally lighting devices, luminous signals, display and every application where the light has to be seen by human observers. Radiometry, on the other hand, is important in all those applications where human being is not involved, but a measurement in terms of energy and/or power is necessary, as for example the characterisation of optical fibre devices, photovoltaic installations, photolithography for nano-micro-fabrication, optical sensors for environment monitoring, high-power lasers used in metal cutting and welding, single photon methods for quantum technologies.

Primary standards

A primary standard is an instrument that can generate or detect the energy (or power) of an optical radiation by a direct reference to another measurable physical phenomenon and does not need calibration against any other radiometric quantities. There are two types of primary standards in general use for realizing radiometric units: primary standards based on sources (blackbody source and synchrotron radiation) and primary standards based on detectors (Electrical Substitution Radiometer).

Blackbody source

The emitted power by a perfect blackbody cavity is given by the Planck's law:

$$L(\lambda, T) = \frac{c_1}{\lambda^5} \frac{1}{\exp\left(\frac{c_2}{\lambda T}\right) - 1}$$

where $L(\lambda, T)$ is the spectral radiant power emitted by the blackbody i.e. the power per unit area per unit of wavelength interval, λ is the wavelength and T is the thermodynamic temperature. The values of the constants c_1 and c_2 are

$$c_1 = 3.7415 \cdot 10^{-16} \text{ W/m}^2 \text{ and } c_2 = 1.4388 \cdot 10^{-2} \text{ m}\cdot\text{K}$$

The spectral power distribution of some blackbody sources, at different temperatures, is shown in Fig. 1. A blackbody source operated around room temperature has a peak in the emitted spectrum in the infrared region around $10 \mu\text{m}$; a blackbody source with a peak in the visible region must be heated at higher temperature, in the range between 3000 K and 6000 K.

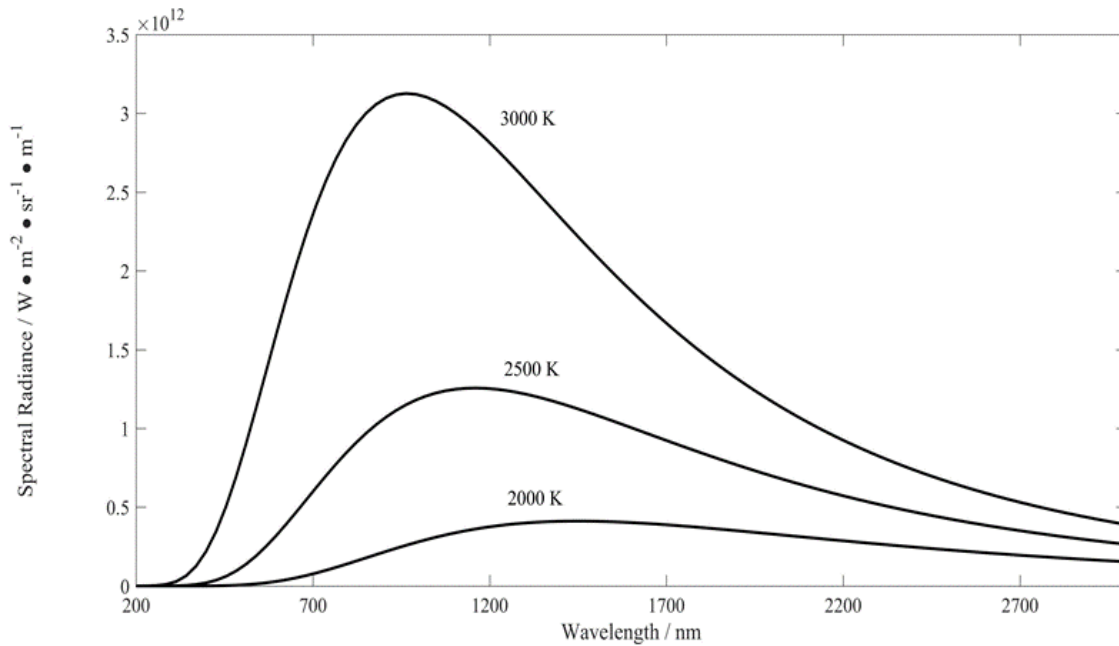

Fig. 1. – Spectral emission of blackbody sources at different temperatures

For metrological purposes, Planck’s law can be exploited in two different ways:

- a blackbody with known temperature can be used as a radiation-source standard to realize radiometric units;
- a blackbody can also serve as a temperature standard, if the emitted (spectral or total) radiance is measured with sufficient accuracy.

Hence, there is a close connection between blackbody-based radiometry and radiation thermometry. Today, in high-accuracy applications, the thermodynamic temperature of the blackbody cavity is determined by use of a calibrated filtered detector, commonly speaking referred as a “filter radiometer”. A blackbody at the freezing temperature of platinum (2045 K) was at the core of a previous definition for the realization of the candela (9th CGPM, 1948). In 1979, because of the experimental difficulties in realizing a Planck radiator at high temperatures and the new possibilities offered by radiometry, i.e., the measurement of optical radiation power, the 16th CGPM (1979) adopted a new definition of the candela.

Synchrotron radiation source

Electrons travelling at high velocity on a storage ring emit synchrotron radiation. A synchrotron-radiation source provides a broadband, continuous spectrum that ranges from infrared to x-ray wavelengths with high brightness and low beam divergence. In addition, the properties of the synchrotron radiation (such as spectral distribution, polarization, and angular divergence) can be accurately calculated from the machine parameters (geometry, electron current, magnetic field) through the use of Schwinger equation (Fig. 2) [1]. Synchrotron radiation covers a huge dynamic range in photon flux of about 12 decades by properly adjusting the number of stored electrons, in the range from maximum current to a single stored electron, without changing the shape of the emitted spectrum. These characteristics make synchrotron radiation much superior to conventional laboratory light sources for UV, vacuum ultraviolet (VUV), and x-ray radiometry.

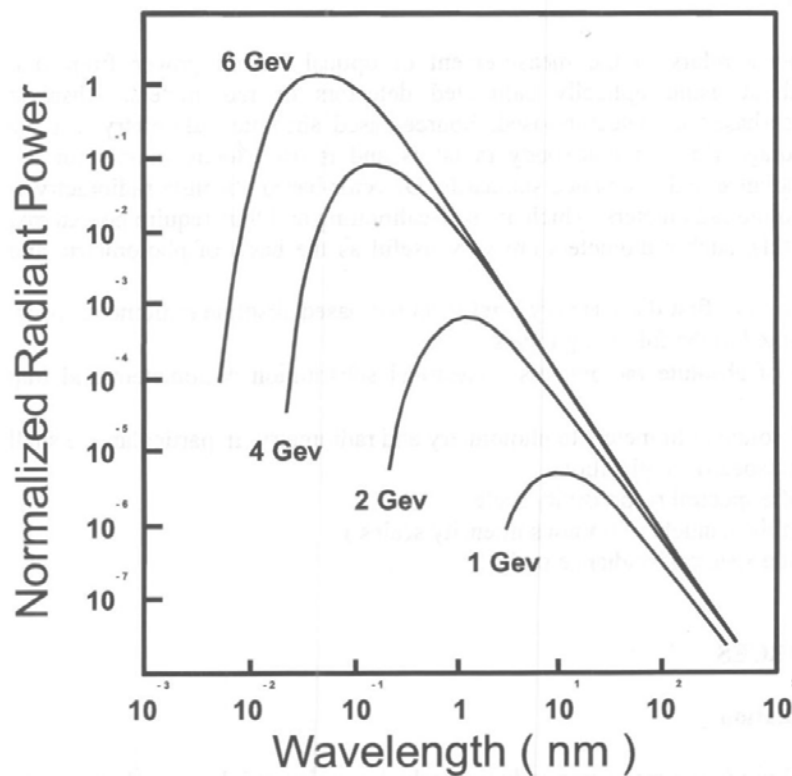

Fig. 2 – Typical spectral power distribution for synchrotron radiation at different electron energies.

Electrical Substitution Radiometer

Electrical-substitution radiometers (ESRs) serve as primary standards for optical power at many national metrology institutes around the world. In the ESR the heating effect produced by optical radiation impinging on an optical absorber is compared with the effect produced by electrical power heating. Fig. 3 shows the key components of an ESR: an optical absorber, a thermometer, an electrical heater and a thermal link. The optical absorber heats up when irradiated by laser; to achieve absorption close to unity light traps or cavity design are used for multiple reflections. Temperature rise of the optical absorber is measured with a thermometer; with electrical heating we reproduce an equivalent temperature change.

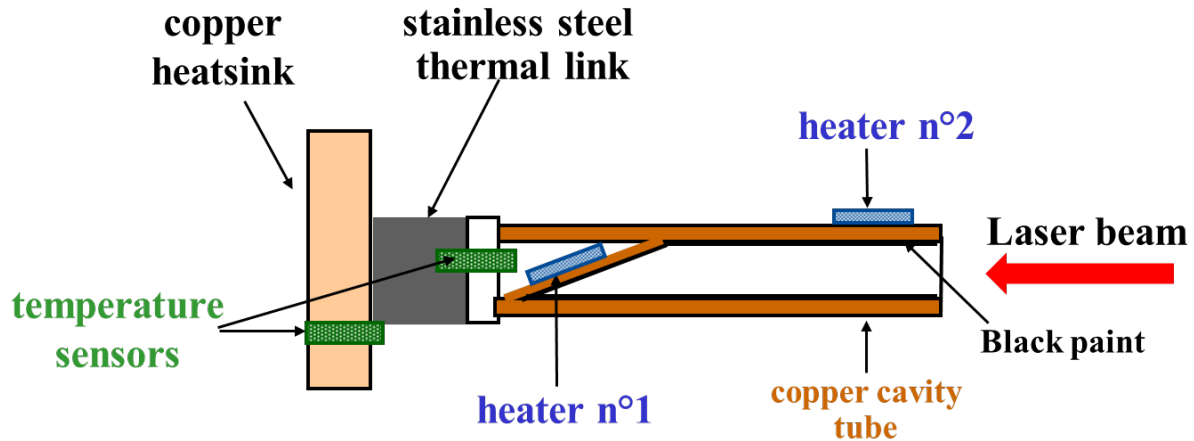

Fig. 3 – The Electrical Substitution Radiometer (ESR) optical absorber (black painted cavity), heater, temperature sensor.

For the substitution principle, when the electrical power heating effect equate the optical heating effect then, the electrical power is equal to the optical power impinging on the absorber. In this way the optical power measurement is traced to SI electrical units. This technique is today implemented in instruments operated at cryogenic temperatures with the benefits for the reduced specific heat capacity and higher thermal diffusivity of the absorber materials (shorter time constant), low background radiation, superconducting electrical connections [2, 3]. The ESR in use today are operated at liquid helium (4.2 K), with relatively large optical absorbing cavity (about 10 s of time constant), in laser based facility (collimated beam), at around 100 μ W power level. The measurement uncertainty is typically around 100 ppm.

The state of the art in primary standard

The improvement of primary standards for radiometry follows two main streams: carbon nanotube cryogenic radiometer under development by NIST, and Predictable Quantum Efficiency Detector developed within a European consortium of National Metrology Institute.

Carbon Nanotube for radiometers

A new cryogenic ESR has been developed by NIST, gaining advantage from lithographic and micromachining fabrication techniques, integrating together the optical absorber, thermometer, electrical heater and thermal link in an engineered single chip [4]. The optical absorber is based on vertically-aligned carbon nanotubes (VACNT), the blackest known substance (Fig. 4). However, typical VACNT samples are not perfect optical absorbers and their reflectance increase at short wavelengths. The reflectance of VACNT depends on many variables – including density, height, uniformity, and alignment. Measured optical reflectance at 1550 nm, was 6.5×10^{-4} which should be even reduced by exposure to oxygen plasma (ashing) below 100 ppm in visible [5, 6, 7]. Anyway, the absorption of VACNT is high enough to allow a planar design for the optical absorber (avoiding light trap or cavity) and the integration with the remaining key components of the ESR (thermometer, heater and thermal link) on a single chip (Fig. 5). This allow to design an ESR with shorter time constants (8 ms), high reproducibility and low cost compared to traditional cryogenic radiometers.

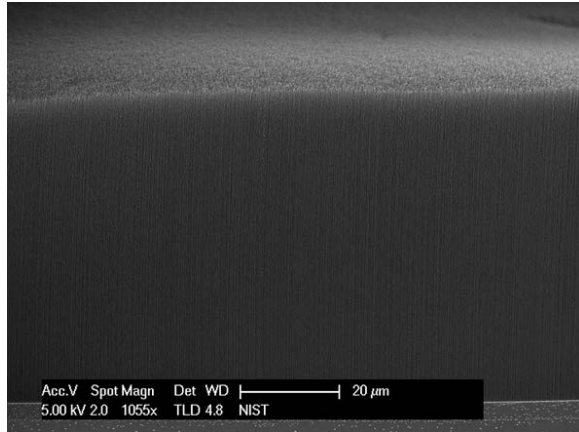

Fig. 4 – Electron microscope view of the multiwall Vertically-Aligned Carbon Nanotubes (VACNT). (kind courtesy of NIST Boulder)

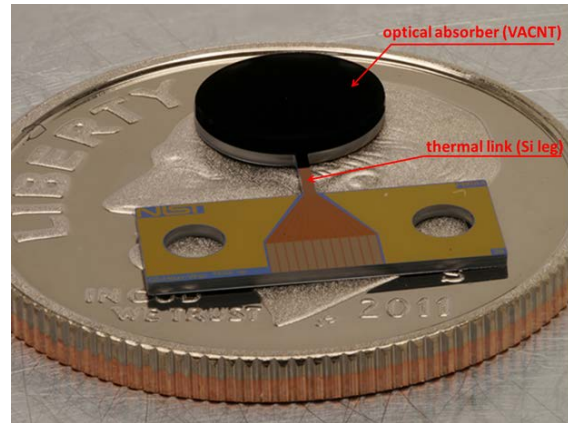

Fig. 5 – Planar bolometric radiometer designed for optical fiber power measurements. The chip include the optical absorber (VACNT), the thermal link (micro-machined Si leg), thermometer and electrical heater. (kind courtesy of NIST Boulder)

Predictable Quantum Efficiency Detector

The Predictable Quantum Efficiency Detector (PQED) is a new radiometric standard based on the photoelectric effect in silicon semiconductors working at liquid nitrogen temperature, developed under European Joint Research Projects. The spectral responsivity, R , of an ideal photoelectric detector can be expressed using fundamental constants e , h , c and vacuum wavelength λ , according to $R(\lambda) = e\lambda/hc$. This equation is based on the assumption that every incident photon generates exactly one elementary charge carrier. The performance of specially designed silicon detectors can approach the performance of the ideal quantum detector in the visible wavelength range, although the photon-to-electron conversion is always slightly affected by charge carrier losses and reflection. In 1978, Hansen developed induced junction photodiodes to be used as an alternative to diffused p–n junction photodiodes [8]. The advantage of these photodiodes is improved charge carrier collection efficiency when used with reverse bias voltage. Geist et al [9] proposed, using induced junction photodiodes at cryogenic temperatures, to further reduce internal losses. Recent modelling of internal carrier losses in induced junction photodiodes, by Gran et al [10], shows that when operating at low temperatures and in reverse bias mode, induced junction photodiodes should be capable of converting absorbed photons to electron–hole pairs with carrier losses smaller than 1 ppm in the 400 nm to 600 nm wavelength range. Moreover, the simulations also indicate that photodiodes work well at room temperature over the full visible wavelength range having a known external quantum efficiency within an uncertainty of approximately 100 ppm [10]. A critical parameter in designing photodiodes is the thickness of the silicon dioxide layer on top of the silicon substrate. The thicker the oxide, the easier it is to obtain the silicon inversion layer. With a properly chosen thickness, specular reflectance can be suppressed significantly when using p-polarized incident light in a multiple reflection trap detector. The photodiodes produced (Fig. 6) have active areas of $11 \times 22 \text{ mm}^2$ with an oxide layer thickness of 220 nm or 300 nm. Photodiode oxide thickness and its spatial uniformity were measured with the INRIM ellipsometer facility [11]. To reduce reflectance losses, the induced junction photodiodes were assembled into a light trapping configuration (Fig. 7) designed to develop a quantum detector with efficiency close to 100 % [12]. PQED responsivity was predicted on the basis of fundamental constants and material parameters [10, 13]. Two prototype PQEDs were assembled and validated; the spectral responsivity of the PQEDs was measured with cryogenic electrical

substitution radiometers at the Physikalisch-Technische Bundesanstalt (PTB) and the Czech Metrology Institute (CMI); the experimental results show good agreement with the modelled response of the PQED to optical radiation, as well as near-unity external quantum efficiency [14].

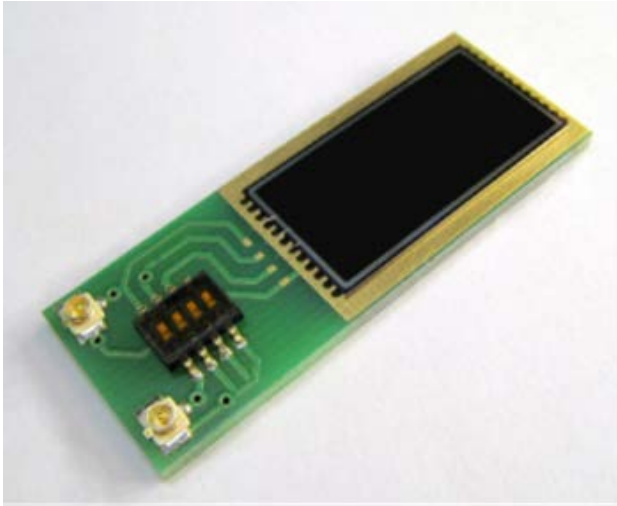

Fig. 6 - PQED photodiode on a PCB

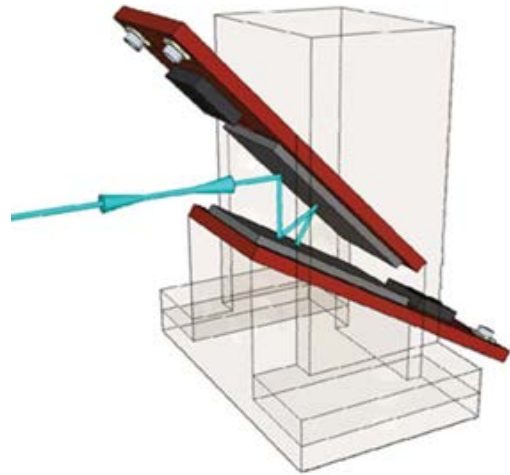

Fig. 7 – 3D structure of the PQED.

The outstanding performance of the PQED at 77 K offers an opportunity to push the boundaries of fundamental physics. Comparing the results obtained from tests conducted on high accuracy standards based on thermodynamics (i.e., cryogenic radiometers) and electromagnetism (PQEDs) will play a significant role in searching for consistency between the two fields. Fundamental limitations can be tackled by basic research on the interaction between light and matter, on new materials and new structures with revolutionary photonic properties.

Counting photons

The “*mise en pratique*” for the definition of the candela and associated derived units [15] includes information on the practical realization of units for photometric and radiometric quantities using photon-number-based techniques because of recent advances in the generation and manipulation of individual photons show great promise of producing radiant fluxes with a well-established number of photons.

Spontaneous Parametric Down-Conversion (SPDC)

SPDC is a quantum effect consisting of the spontaneous decay, inside a non-linear crystal, of one photon from a pump (p) beam, into a pair of photons arbitrarily referred to as signal (s) and idler (i) (Fig. 8) [16]. This decay process must obey the laws of energy conservation, $\omega_p = \omega_s + \omega_i$, and momentum conservation (or phase matching), $\mathbf{k}_p = \mathbf{k}_s + \mathbf{k}_i$, where ω_p , ω_s and ω_i are the optical frequencies, and \mathbf{k}_p , \mathbf{k}_s and \mathbf{k}_i the wave vectors (within the crystal) identified by their subscripts.

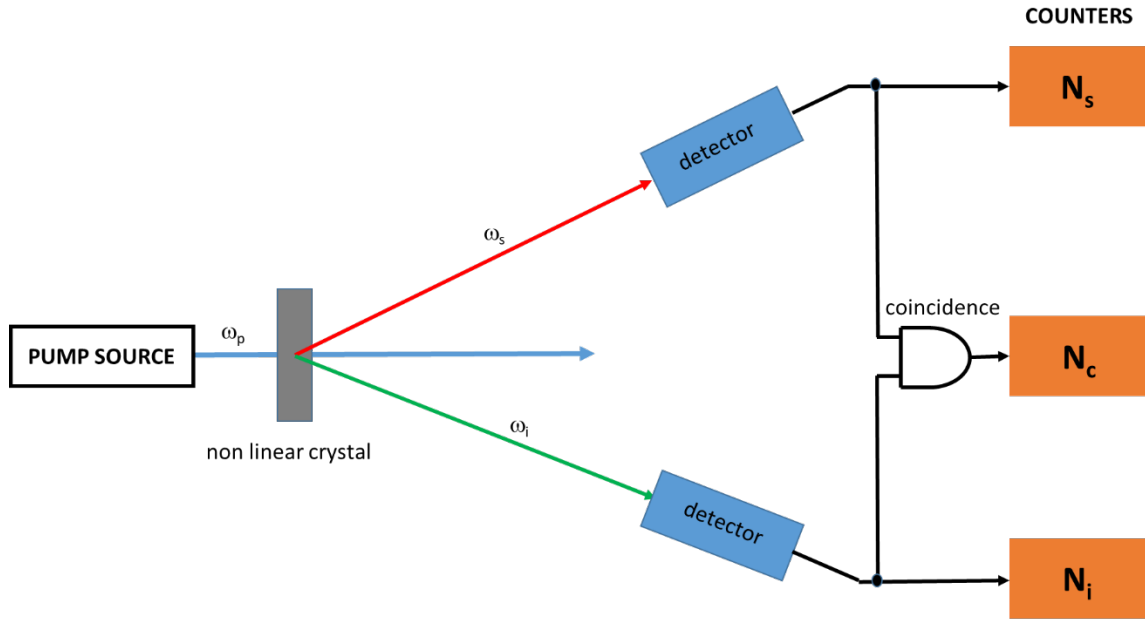

Fig. 8 – Set-up for the measurement of detection efficiencies by means of photon pairs generated by SPDC

The probability of spontaneous decay into a pair of correlated photons is usually very low, of the order of 10^{-9} or lower, therefore with typical pump power of the order of some milliwatts, the fluorescence emission lies at the level of the photon-counting regime. As the photons are produced in pairs and because of restrictions imposed by energy and momentum conservation, the detection of the direction and energy of one photon indicates the existence of a pair-correlated photon, with definite energy and direction. Using coincidence-measurement techniques, these characteristics allow absolute calibration of a photodetector without the need for an absolute radiometric reference [17, 18]. If two photon-counting detectors are placed downstream of the non-linear crystal, along the directions of propagation of the correlated-photon pair, the detection of an event by one detector guarantees the presence of a photon in the conjugate direction. If N is the total number of photon pairs emitted from the crystal in a given time interval, N_s , N_i and N_c are the mean number of events recorded, in the same time interval, by the signal detector, idler detector and in coincidence, respectively, we have the following relationships: $N_s = \eta_s N$ and $N_i = \eta_i N$, where η_s and η_i are the detection efficiencies on the signal and idler arms, respectively. The number of events in coincidence is $N_c = \eta_s \eta_i N$, owing to the statistical independence of the two detectors. The detection efficiencies are easily derived from the three measured values: $\eta_s = N_c / N_i$, $\eta_i = N_c / N_s$.

Single-Photon Source (SPS)

In radiometry a predictable single-photon source i.e., a source that emits a calculable number of photons at a specific rate and wavelength could act as standard source. The development of a new standard sources based on the emission of one photon at time is a relevant step forward for the photon-counting metrology. The possibility to increase the emission rate of these sources will help to bridge the gap between classical radiometry and photon-counting regime [19, 20]. In the last years, a lot of resource have been devoted to identify new single-photon sources (SPS) and improve the specifications of those known [21, 22, 23]. Three main types of SPS have been investigated: (a) defect centres in nano-diamond, (b) quantum dot and (c) molecule. The defect centres in nano-diamond, typically Nitrogen vacancy (NV) or Silicon vacancy (SiV), are stable emitters at room temperature,

optically pumped, with emission rate up to 10^6 photons/s; their main disadvantage is the low collection efficiency for emitters in bulk material. Quantum dot are typically based on GaAs semiconductor able to operate at telecomm wavelength and are electrically pumped; their disadvantage is the low temperature operation and the low collection efficiency. Finally the molecule based SPS have shown the highest emission rate but again they must be operated at low temperature in order to avoid degradation working at room temperature. The collection efficiency of each of these emitters could be greatly enhanced using proper coupling structures [24].

Photometry – The realization of the candela

According to the 16th Conference of Weights and Measures of 1979, the SI unit, the candela, is the luminous intensity, in a given direction, of a source that emits monochromatic radiation of frequency 540×10^{12} hertz and that has a radiant intensity in that direction of 1/683 watt per steradian. An important consequence of this definition is the possibility to realize the candela based on ESR and laser sources. Fig. 9 shows a typical traceability chain from the ESR to the luminous intensity standard lamps: a transfer detector is calibrated against a cryogenic radiometer at a number of discrete wavelength; by means of proper interpolation techniques the spectral responsivity of the transfer detector is extended over all the visible wavelength range. A silicon photodiode is spectrally calibrated against the transfer detector and then is spectrally corrected adding a properly designed filters in such a way that the product of the relative spectral responsivity of the silicon photodiode and the relative transmittance of the filter match the relative spectral response of the average human eye $V(\lambda)$, as close as possible. This filtered photodiode, with a calibrated aperture area in front, realize a reference photometers to be used to calibrate the luminous intensity of standard lamps.

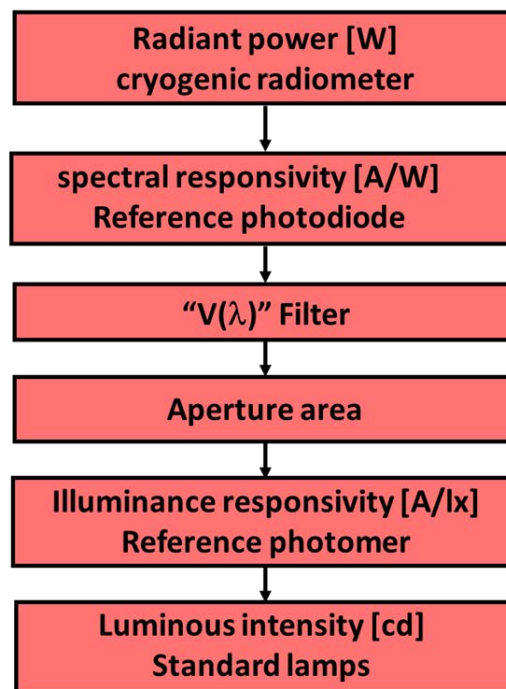

Fig. 9 – Traceability chain for the realization of the candela

References

1. Schwinger, J., On the classical radiation of accelerated electrons”, *Physical Review*, 1949, 75, 1912-25.
2. Martin, J.E., Fox, N.P., and Key, P.J., A cryogenic radiometer for absolute radiometric measurements, *Metrologia*, 1985, 21, 147-155.
3. Hoyt C.C. and Foukal, P.V., Cryogenic radiometers and their application to metrology, *Metrologia*, 1991, 28, 163-167.
4. N.A. Tomlin, M. White, I. Vayshenker, S.I. Woods, J.H. Lehman, *Metrologia* 52, 2, 376 – 383 (2015).
5. Lehman J, Sanders A, Hanssen L, Wilthan B, Zeng J and Jensen C 2010 *Nano Lett.* 10 3261–6;
6. Chunnillall C J, Lehman J H, Theocharous E and Sanders A 2012 *Carbon* 50 5348–50;
7. Tomlin N, Curtin A, White M and Lehman J 2014 *Carbon* 74 329–32
8. Hansen T 1978 Silicon UV-photodiodes using natural inversion layers *Phys. Scr.* 18 471–5
9. Geist J, Brida G and Rastello M L 2003 Prospects for improving the accuracy of silicon photodiode self-calibration with custom cryogenic photodiodes *Metrologia* 40 S132–5
10. J. Gran, T. Kübarsepp, M. Sildoja, F. Manoocheri, E. Ikonen and I. Müller Simulations of a predictable quantum efficient detector with PC1D *Metrologia* 49, S130 (2012)
11. M. White, L. Lolli, G. Brida, J. Gran, M. Rajteri, Optical constants and spatial uniformity of thermally grown oxide layer of custom, induced-junction, silicon photodiodes for a predictable quantum efficient detector, *Journal of Applied Physics*; Jun 2013, Vol. 113 Issue 24, p243509
12. M. Sildoja, F. Manoocheri, and E. Ikonen, Reflectance Calculations for a Predictable Quantum Efficient Detector, *Metrologia* 46, S151-S154 (2009)
13. M. Sildoja, F. Manoocheri, M. Merimaa, E. Ikonen, I. Müller, L. Werner, J. Gran, T. Kübarsepp, M. Smîd and M. L. Rastello, Predictable quantum efficient detector: I. Photodiodes and predicted responsivity *Metrologia* 50, 385 (2013)
14. I. Müller, U. Johannsen, U. Linke, L. Socaciu-Siebert, M. Smîd, G. Porrovecchio, M. Sildoja, F. Manoocheri, E. Ikonen, J. Gran, T. Kübarsepp, G. Brida and L. Werner, Predictable quantum efficient detector: II. Characterization and confirmed responsivity *Metrologia* 50, 395 (2013)
15. J. Zwinkels, A. Sperling, T. Goodman, J. Campos Acosta, Yoshi Ohno, Maria Luisa Rastello, M. Stock and E. Woolliams, Mise en pratique for the definition of the candela and associated derived units for photometric and radiometric quantities in the International System of Units (SI), *Metrologia*, Volume 53, Number 3, 2016
16. Klyshko D. N., *Photons and Nonlinear Optics*, New York, Gordon and Breach, 1988.
17. Brida G., Castelletto S., Novero C., Rastello M. L., *Metrologia*, 1998, 35, 397-401.
18. A L Migdall, R U Datla, A Sergienko, J S Orszak and Y H Shih, Absolute detector quantum-efficiency measurements using correlated photons, *Metrologia*, Volume 32, Number 6
19. J. Y. Cheung, C. J. Chunnillall, E. R. Woolliams, N. P. Fox, J. R. Mounford, J. Wang, and P. J. Thomas, “The quantum candela: a re-definition of the standard units for optical radiation,” *J. Modern Optics* 54, 373 (2007)
20. J. C. Zwinkels, E. Ikonen, N. P. Fox, G. Ulm, M. L. Rastello, “Photometry, radiometry and ‘the candela’: evolution in the classical and quantum world”, *Metrologia* 47, R15 (2010)
21. M. Oxborrow, A. Sinclair, "Single-photon sources", *Contemporary Physics*, 46, 173 (2005)
22. S. Scheel, "Single-photon sources – an introduction", *Journal of Modern Optics*, 56, 141 (2009)
23. G.S. Buller, R.J. Collins, “Single-photon generation and detection”, *Measurement Science and Technology*, 21, 012002 (2010)
24. X. W. Chen, S. Götzinger, V. Sandoghdar, “99 % efficiency in collecting photons from a single emitter”, *Optics Letters* 36, 3545 (2011)