



ISTITUTO NAZIONALE DI RICERCA METROLOGICA Repository Istituzionale

Cryocooled Josephson standards for AC voltage metrology

Original

Cryocooled Josephson standards for AC voltage metrology / Durandetto, P; Sosso, A; Monticone, E; Trinchera, B; Fretto, M; Lacquaniti, V. - In: JOURNAL OF PHYSICS. CONFERENCE SERIES. - ISSN 1742-6588. - 841:(2017), p. 012031. [10.1088/1742-6596/841/1/012031]

Availability:

This version is available at: 11696/57111 since: 2021-04-22T11:24:10Z

Publisher:

IOP

Published

DOI:10.1088/1742-6596/841/1/012031

Terms of use:

This article is made available under terms and conditions as specified in the corresponding bibliographic description in the repository

Publisher copyright

(Article begins on next page)

PAPER • OPEN ACCESS

Cryocooled Josephson standards for AC voltage metrology

To cite this article: P Durandetto *et al* 2017 *J. Phys.: Conf. Ser.* **841** 012031

View the [article online](#) for updates and enhancements.

Related content

- [The Josephson locked synthesizer](#)
Blaise Jeanneret, Frédéric Overney and Alain Rüfenacht
- [Precise Measurement of a 20-V Programmable Josephson Voltage Standard System](#)
Takahiro Yamada, Hirotake Yamamori, Hitoshi Sasaki et al.
- [Josephson-based full digital bridge for high-accuracy impedance comparisons](#)
Frédéric Overney, Nathan E Flowers-Jacobs, Blaise Jeanneret et al.

Cryocooled Josephson standards for AC voltage metrology

P Durandetto, A Sosso, E Monticone, B Trinchera, M Fretto and V Lacquaniti

I.N.Ri.M. - Istituto Nazionale di Ricerca Metrologica - Strada delle Cacce, 91 - 10135 Torino (Italy)

E-mail: p.durandetto@inrim.it

Abstract. The Josephson effect is worldwide used as a basis for constant reference voltages in national metrological institutes and in calibration laboratories of industry. Research on Josephson voltage standards is aiming at a fundamental change also in the metrology of the volt for AC and arbitrary waveforms: programmable Josephson voltage standards converting a digital code into a quantum-accurate stepwise waveform are already available in primary laboratories and even more advanced standards for converting sub-nanosecond binary coded pulses into any arbitrary signal with quantum accuracy are now actively developed and tested. A new experimental setup based on a two-stage Gifford-McMahon cryocooler has been developed at INRiM for the operation of AC-Josephson voltage standards. Among its distinct features, the possibility of employing both the aforementioned techniques (programmable and pulsed Josephson voltage standards) is particularly interesting. Quantum-based AC voltage sine waves have been synthesized with both programmable and pulse-driven arrays, although their accuracy is still limited by thermal oscillations due to the cryocooler piston motion.

1. Introduction

The application of superconducting devices based on Josephson effect for the synthesis of AC voltage waveforms has been investigated for many years. Indeed, arrays of many thousands of Josephson junctions for DC voltage standards are, to date, among the most important achievements of superconducting electronics.

Josephson Voltage Standards (JVSs) are employed for high precision DC voltage calibrations since the early years after the phenomenon was predicted by Brian Josephson in 1962 [1]: he describes how it can be used to relate, in some conditions, the constant voltage across a junction to the frequency of the alternate bias current flowing through it.

For voltage metrology, a Josephson junction is essentially described by the equation expressing the relationship between the frequency of the current and the voltage across the junction:

$$V_n = n \cdot \frac{h}{2e} \cdot f \quad (1)$$

where n is an integer, e is the electron charge and h is the Planck constant. Voltage V_n and frequency f are related by a direct proportionality and, since the coefficient is given in terms of the two fundamental constants e and h , its value is universal. Eq. (1) tells us that driving a Josephson junction by a microwave source of frequency f , constant-voltage steps at integer



multiples of $h/2e$ appear. Junction voltages of about 150 μV are obtained by radiating it with microwave bias frequencies around 70 GHz, for $n = 1$. To achieve the output voltage required for a practical quantum standard, hysteretic Superconductor-Insulator-Superconductor (SIS) technology was successfully adopted, following an idea by Levinsen [2] to fabricate arrays with tens of thousands of highly uniform junctions and output up to 10 V. Arrays with several thousands of DC Josephson junctions have been used for many years as voltage standards with ultimate accuracy (up to few parts in 10^{11} [3]). Lately, voltage standard research has focused on the metrological application of Josephson effect for AC voltages in a wide range of frequencies and amplitudes. Quantum AC voltage standards are based on non-hysteretic Josephson junctions that can be realized with SNS (N: normal metal) self-shunted junctions, where voltage is easily adjustable by varying the bias current and Shapiro steps are intrinsically stable.

The main techniques employed for the generation of quantum-based waveforms are programmable and pulse-driven AC-JVSs. Programmable arrays are subdivided in sub-circuits with series-connected junctions to generate voltages following a power of 2-sequence (1, 2, 4, 8, 16, ...). Independent bias currents are used to activate/deactivate the array's subsections, thus controlling the output voltage as in DACs of semiconductor electronics. Programmable arrays can generate stepwise quantum waveforms in the kHz range and amplitudes up to 20 V [4]. On the other hand, it is possible to use short pulses instead of a sinusoidal rf (radiofrequency) signal, allowing to modulate the rf period while keeping junctions phase-locked over a wide range of frequencies (up to the MHz range) [5]. The principle of operation of pulse-driven JVS (or Josephson Arbitrary Waveform Synthesizer, JAWS) is based on the quantization of magnetic flux, since the time-integrated area of every voltage pulse of each junction is exactly equal to the magnetic flux quanta $\phi = h/2e$. Fundamental accuracy follows from the control of the flux quanta transferred through the junctions by the pulse signal and the output voltage is exactly calculable from fundamental constants if the pulse repetition rate is known [6].

Cryogen-free operation of JVSs is now regarded as crucial to widen the range of applications of quantum standards, due to its greater ease of use with respect to liquid helium and for possible shortages and high cost of the latter. Furthermore, in cryocooler the length of the cables can be at least halved with respect to liquid helium system, allowing to minimize the systematic errors that affect high-frequency voltage measurements [7].

In this paper we present last results obtained with both programmable and pulse-driven Josephson standards in cryocooler setup.

2. Measurement setup

2.1. Cryogenic system

The cryocooler in use for the operation of programmable and pulse-driven arrays is a two-stage GM type with top loading sample assembly, 1 W cooling power at 4.2 K, 8 kW compressor input power and minimum temperature achievable of about 2.9 K with no load. The cold finger top was fitted with an additional copper disk (coldplate) that contains a germanium resistance temperature sensor and a heater for temperature monitoring and control (Fig. 1). A second thermometer (a silicon diode, b) in Fig. 1) is positioned close to the chip in order to better estimate the array operating conditions and detect unwanted thermal gradients [8]. Indeed, when a Josephson array is irradiated by rf signal, it warms up and consequently induces the rise of the local temperature and the worsening of the array's operating margins. All heat has to be dissipated through a series of suitable thermal links with high thermal conductivity [9]. All measurements performed make use of a cryopackage structure which is already described in [10]. Finally, GM coolers are affected by temperature oscillations of the coldplate that are caused by the cryocooler piston periodic motion and lead to the worsening of AC-JVSs operation. Interventions aimed at reducing these effects are under study.

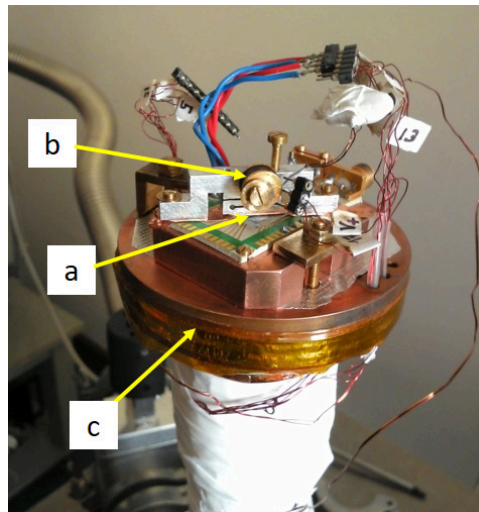

Figure 1. Picture of the cryocooler's coldplate with a Cu sample holder positioned on it. a) is the Josephson chip, b) is a silicon-diode thermometer and c) is the heater wire wound around the coldplate, suitably guarded with kapton tape.

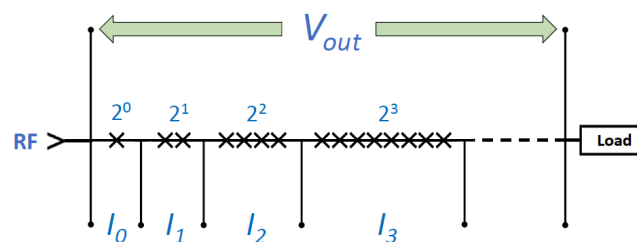

Figure 2. Scheme of programmable JVS.

2.2. Programmable Josephson standard

As mentioned before, Programmable-JVS (PJVS) is made up by series-connected subarrays whose size follows a power of 2-sequence (Fig. 2). Each subarray is individually current-biased on the n^{th} Shapiro step (where n is typically 0 or ± 1). The arrays under test were realized in cooperation with PTB (Physikalisch-Technische Bundesanstalt, Germany) and are made up by 8192 Nb/Al-AlO_x/Nb (SNIS) intrinsically-shunted Josephson junctions. The SNIS technology is interesting for application to a cryocooled standard, allowing to set a compromise between device and refrigerator requirements. Indeed, an important requirement for cryocooler operation is the temperature stability of the electrical parameters above 4.2 K, as explained in reference [11]. While SIS and SNS junctions show temperature dependence of the electrical parameters V_c and I_c below or above 4.2 K respectively, SNIS junctions can minimize it over an extended range by optimizing some intrinsic properties. Moreover PJVS operation requires rf signal transmission through a microwave guide (WR-12, 60÷90 GHz) that can convey significant heat to the coldplate. We adopted a stainless steel guide, with gold-coated internal surface to reduce the dramatic signal attenuation of the stainless steel [8].

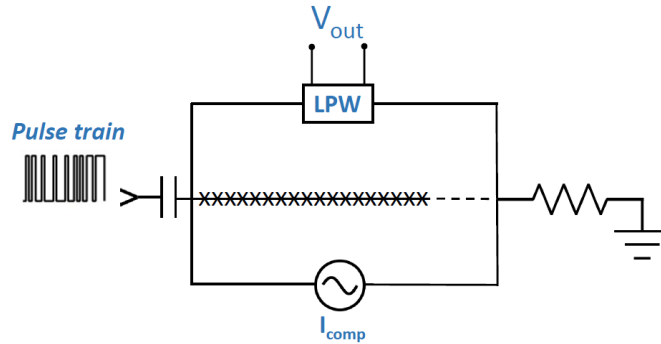

Figure 3. Scheme of pulse-driven JVS.

2.3. Pulse-driven Josephson standard

With pulse-driven technique AC and arbitrary voltages can be obtained by modulating the repetition frequency of pulses, allowing the synthesis of very pure signals [12]. The desired waveform is encoded into a 0/1 or 1/0/-1 bitstream through $\Sigma\Delta$ modulation techniques employed for ADC in electronics (Fig. 3). The work presented here uses arrays of SNS junctions realized by PTB with $\text{Nb}_x\text{Si}_{1-x}$ as barrier material. Our pulse-driven samples consist of two arrays, with 4000 junctions each, integrated on a 10 mm \times 10 mm Si chip. For each array, junctions are arranged in double stacks and are embedded into the center line of a 50 Ω coplanar-wave-guide (CPW) which ensures a suitable propagation of pulses [13]. The chip is mounted onto a chip carrier 23 mm \times 40 mm made on Rogers RO3006. Two conducting CPW paths made of copper with a 2 μm gold layer on top (without nickel) are used for pulse transmission to the arrays. The CPW lines of this carrier are connected to two PCB-SMA launchers for connection to coaxial cables [14]. For the transmission of the pulse train we employed a 50 cm long stainless steel coaxial cable, suitably anchored to the cryocooler first and second stages for reducing the direct thermal link with the external environment at room temperature. A I/O DC-block is needed for the electrical decoupling of the sample and to avoid common-mode voltage errors [15].

3. Results

The main measurements performed with our programmable chip were concentrated on the optimization of operating margins on the 1st and the 2nd Shapiro steps by adjusting coldplate's temperature and microwave input power. The output voltage of the Josephson array was observed and measured with a compact wideband digital modular system for dynamic measurement with fast frame rate [16]. The flatness of voltage steps was determined under microwave radiation by recording the current-voltage (IV) characteristics of all the PJVS subarrays (inset of Fig. 4) and was deduced by a linear fit within 100 μA of current operating margins: for the entire array (8192 junctions) we obtained 0.8 $\mu\text{V}/\mu\text{A}$ at 1.28 V and 0.4 $\mu\text{V}/\mu\text{A}$ at 2.56 V. These results suggest the use of these quantized voltage steps for synthesis of stepwise sine waves. Indeed, as can be seen in Fig. 4, we synthesized sine waves at a frequency of 1 kHz and with amplitude of about 1 V_{rms} at $T \simeq 6.5$ K using the 1st step and of about 2 V_{rms} at $T \simeq 4.7$ K using the 2nd step.

As regards the pulse-driven JVS, to avert any common-mode voltage on the termination resistor, the AC-coupling technique was used [15], [17], where the low-frequency component of the pulse train is removed through a DC-block with the scope of canceling the common-mode signal at the array output. Then, in order to ensure the proper operation of the array, the low-frequency component has to be re-injected as a compensation current signal I_{comp} (see Fig. 3) at the same frequency of the desired waveform and has to be phased with the pulsed signal. The Pulse

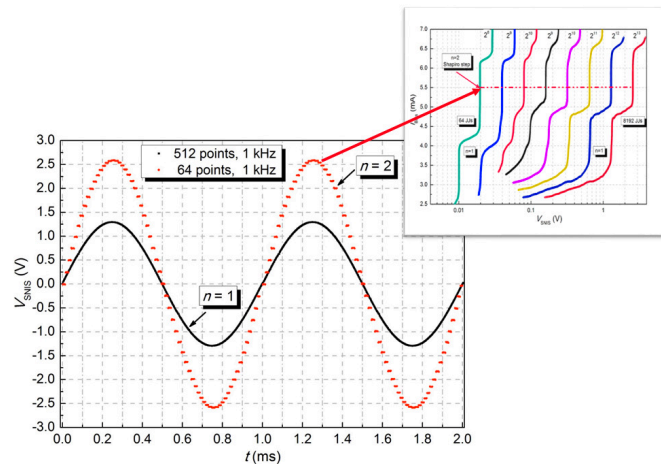

Figure 4. Stepwise sine waves at 1 kHz synthesized with the PJVS array in cryocooler. The black curve ($1 V_{\text{rms}}$) is obtained at $T \simeq 6.5$ K with all the 1st Shapiro steps of the PJVS subsections, while the red curve ($2 V_{\text{rms}}$) is obtained at $T \simeq 4.7$ K with all the 2nd Shapiro steps. The inset shows some of the overlapping quantized steps employed for the synthesis of the $2 V_{\text{rms}}$ waveform, where the horizontal red line represents the common bias current ($\simeq 5.5$ mA) for each section.

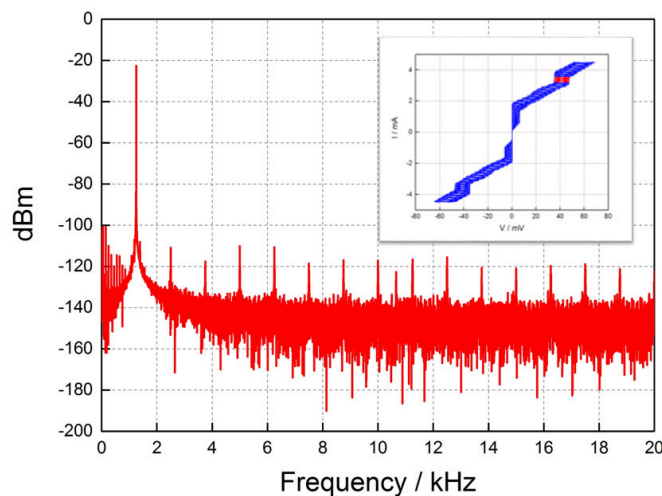

Figure 5. Observed FFT spectrum of a unipolar sine wave at 1.25 kHz at $11.7 \text{ mV}_{\text{rms}}$ obtained with pulse-driven JVS at about 5 K in cryocooler. The inset shows the IV characteristic of the JVS when radiated by the 0/1 pulse pattern of a $\Sigma\Delta$ -modulated sine wave. The red area on the 1st step represents the operating margins exploited for the waveform synthesis.

Pattern Generator (PPG) we employed delivered unipolar non-return-to-zero (NRZ) pulses with a maximum clock frequency of 12.5 GHz. The output voltage was observed and measured with the aforementioned digital modular system, appropriately reconfigured for this experiment. By optimizing five parameters (temperature, pulse amplitude, offset, amplitude and phase of I_{comp}), we observed FFT spectra of unipolar sine waves at 1.25 kHz and amplitudes from 4.3 mV to 11.7 mV, (Fig. 5). The PPG clock frequency was set to 10 GHz. The compensation current

I_{comp} was provided by an additional AC synthesizer locked to the PPG 10 MHz clock reference. System tuning for optimal operating margins has been performed by observing the frequency spectrum at temperatures around 5 K.

4. Conclusion

In this work we presented our helium-free system based on a GM cryocooler for the operation of AC-JVSs. We have demonstrated the feasibility of synthesizing quantum-based sine waves in the kHz range with the two different techniques presented here. Stepwise sine waves with amplitude of $1 V_{rms}$ and $2 V_{rms}$ have been synthesized with the programmable standard by current-biasing on the 1st and the 2nd Shapiro steps respectively, while with the pulsed standard we have generated waveforms with amplitude from 4.3 mV to 11.7 mV and distortion around 80 dBc.

These preliminary characterizations show that the output waveform is affected by temperature fluctuations due to intrinsic vibration of the cryocooler. The use of temperature compensation technique and low-vibration cryocooler systems will further improve the overall performance of the ac-JVS synthesizer.

Acknowledgments

This work was partly carried out with funding by the European Union within the EMPIR project JRP 15SIB04 QuADC. The EMPIR is jointly funded by the EMPIR participating countries within EURAMET and the European Union.

References

- [1] Josephson B D 1962 *Physics letters* **1** 251–253
- [2] Levinsen M, Chiao R, Feldman M and Tucker B 1977 *Appl. Phys. Lett.* **31** 776–778
- [3] Wood B and Solve S 2009 *Metrologia* **46** R13
- [4] Müller F, Scheller T, Wendisch R, Behr R, Kieler O, Palafox L and Kohlmann J 2013 *IEEE Trans. Appl. Supercond.* **23** 1101005–1101005 ISSN 1051-8223
- [5] Kim J, Sosso A and Clark A F 1998 *J. Appl. Phys.* **83** 3225–3232
- [6] Benz S P and Hamilton C A 1996 *Appl. Phys. Lett.* **68** 3171–3173
- [7] Landim R P, Benz S P, Dresselhaus P D and Burroughs C J 2008 *IEEE Trans. Instrum. Meas.* **57** 1215–1220
- [8] Sosso A, Fretto M, Lacquaniti V, Monticone E, Rocci R, Serazio D and Trinchera B 2015 *J. Supercond. Novel Magn.* **28** 1181–1184
- [9] Howe L, Burroughs C J, Dresselhaus P D, Benz S P and Schwall R E 2013 *Applied Superconductivity, IEEE Transactions on* **23** 1300605–1300605
- [10] Durandetto P, Monticone E, Trinchera B, Lolli L, Serazio D, Fretto M and Sosso A 2016 arXiv:1609.03384
- [11] Lacquaniti V, De Leo N, Fretto M, Sosso A, Müller F and Kohlmann J 2011 *Supercond. Sci. Technol.* **24** 045004
- [12] Benz S, Dresselhaus P, Burroughs C and Bergren N 2007 *IEEE Trans. Appl. Supercond.* **17** 864–869
- [13] Kohlmann J, Kieler O F, Iuzzolino R, Lee J, Behr R, Egeling B and Müller F 2009 *IEEE Trans. Instrum. Meas.* **58** 797–802
- [14] Oliver FO K, Thomas S and Johannes K 2013 *World Journal of Condensed Matter Physics* **2013**
- [15] Benz S P, Burroughs C J and Dresselhaus P D 2001 *IEEE Trans. Appl. Supercond.* **11** 612–616
- [16] Trinchera B, Sosso A, Pogliano U, Lacquaniti V, Monticone E, Fretto M, Rocci R, Tet L R and Serazio D 2014 *Precision Electromagnetic Measurements (CPEM 2014), 2014 Conference on (IEEE)* pp 114–115
- [17] Benz S P and Waltman S B 2014 *IEEE Trans. Appl. Supercond.* **24** 1–7