



ISTITUTO NAZIONALE DI RICERCA METROLOGICA Repository Istituzionale

Reference Measurement Systems for the Calibration of Instrument Transformers Under Power Quality Phenomena and their Uncertainties

This is the author's accepted version of the contribution published as:

Original

Reference Measurement Systems for the Calibration of Instrument Transformers Under Power Quality Phenomena and their Uncertainties / Chen, Yeying; Mohns, Enrico; Mingotti, Alessandro; Crotti, Gabriella; Letizia, Palma Sara; Stiegler, Robert; Üaye¹, Hüseyin; Ayhan, Burak; Munoz, Fabio. - (2023). [10.1109/amps59207.2023.10297162]

Availability:

This version is available at: 11696/80139 since: 2024-06-14T12:52:02Z

Publisher:

Published

DOI:10.1109/amps59207.2023.10297162

Terms of use:

This article is made available under terms and conditions as specified in the corresponding bibliographic description in the repository

Publisher copyright

IEEE

© 20XX IEEE. Personal use of this material is permitted. Permission from IEEE must be obtained for all other uses, in any current or future media, including reprinting/republishing this material for advertising or promotional purposes, creating new collective works, for resale or redistribution to servers or lists, or reuse of any copyrighted component of this work in other works

(Article begins on next page)

Reference Measurement Systems for the Calibration of Instrument Transformers Under Power Quality Phenomena and their Uncertainties

Yeying Chen

Dept. 2.3 - Electrical Energy Measuring Techniques, Physikalisch-Technische Bundesanstalt (PTB), Braunschweig, Germany

Enrico Mohns

Dept. 2.3 - Electrical Energy Measuring Techniques, Physikalisch-Technische Bundesanstalt (PTB), Braunschweig, Germany

Alessandro Mingotti

Dept. of Electrical, Electronic, and Information Engineering Alma Mater Studiorum - University of Bologna, Bologna, Italy

Gabriella Crotti

Istituto Nazionale di Ricerca Metrologica (INRIM), Torino, Italy

Palma Sara Letizia

Istituto Nazionale di Ricerca Metrologica (INRIM), Torino, Italy

Robert Stiegler

Institute of Electrical Power Engineering and High Voltage Engineering (IEEH) Technische Universität Dresden, Dresden, Germany

Hüseyin üaye¹

Power and Energy Laboratory, TÜBİTAK National Metrology Institute (TÜBİTAK UME), Kocaeli, Türkiye

Burak AYHAN

Power and Energy Laboratory, TÜBİTAK National Metrology Institute (TÜBİTAK UME), Kocaeli, Türkiye

Fabio Munoz

VSL, Dutch Metrology Institute, Delft, The Netherlands

Author Keywords

- reference measurement systems,
- instrument transformers,
- power quality,
- traceability,
- uncertainties

Abstract:

This paper introduces the reference measurement systems for calibrating instrument transformers under power quality phenomena and their associated novel uncertainties. The systems are lately developed at the national metrology institutes in European countries within the frame of the European project 19NRM05 "IT4PQ - Measurement methods and test procedures for assessing the accuracy of instrument transformers for power quality measurements". It's worth noting that the setups, as presented in the paper, are an improved extension of the system already developed in terms of generated waveforms and system characterization level. Especially, the detailed system setups and methods for combined instrument transformer calibrations are debuted. Moreover, new characterization tests were performed by using all the presented reference measurement systems.

Introduction

The development of smart grids, renewable energy integration [1], and large-scale power electronic devices [2] has led to significant changes and advancements in power quality monitoring [3]. Precise measuring instrumentation becomes crucial for effective power quality (PQ) monitoring. Instrument Transformers (ITs) are essential components for power quality measurement (PQM) in electricity grids, as they reduce voltages and currents to compatible levels for measuring instruments. However, there is currently a lack of standards specifically addressing ITs for PQM in electricity grids at Medium / High Voltage (MV / HV) levels, and no National Metrology Institute (NMI) currently offers traceable calibrations for ITs designed for this purpose. This gap in standardization is concerning, as research and literature have highlighted the potential for significant errors introduced by ITs in PQM. Therefore, a European project 19NRM05 “IT4PQ” has been started in 2020.

The overall goal of the “IT4PQ” project is to develop the metrological framework that facilitates the traceable calibration of instrument transformers employed for PQ measurements in electricity grids. Furthermore, the project aims to provide a robust basis for future standardization to the International Electrotechnical Commission (IEC) Technical Committee 38 (TC 38) about the use of ITs for PQ from IEC TC 38 [4].

One of the objectives of IT4PQ is to develop and establish appropriate reference measurement systems for ITs and techniques for assessing the relevant uncertainty contribution of ITs to PQ indices [5]. Thereby, traceable test procedures for reference setups to calibrate industrial ITs are used for PQM, by covering limits of PQ disturbances of the relevant standards of IEC 61000 and EN 50160; and evaluating the ITs performance based on the worked-out PQ indices. The reference measuring systems should allow calibration of ITs up to 2 kA for currents and up to 36 kV for the voltage with a higher bandwidth up to 9 kHz.

In this paper, the improved reference measurement system in the presence of power quality (PQ) disturbances and their new uncertainties are presented. The reference measurement system has been developed at PTB - the German NMI, for current transformers (CTs); at INRIM - the Italian NMI, for voltage transformers (VTs); and at TUBITAK - the Turkey NMI, for three-phase combined instrument transformers (ITs).

Reference Measurement System for Cts

A. Setups of the Reference Measurement System

The calibration process for current transformers under power quality phenomena involves a reference measurement system consisting of several components. Typically, these components include a current generation system, a set of reference CTs with the corresponding precision measuring resistors [6], a high-precision 2-channel measuring system and the device under test (DUT). The laboratory setups of the reference measurement system for CT and LPCT characterization in presence of PQ disturbances developed and characterized at PTB is shown in Fig. 1.

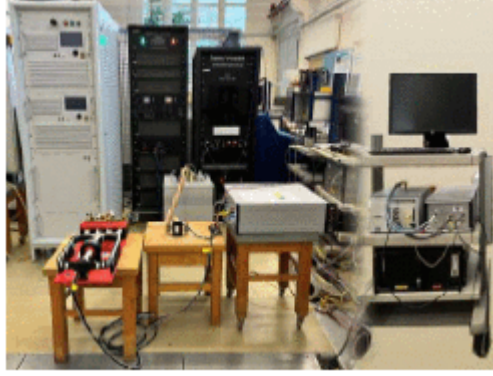

Fig. 1.

Ptb laboratory setups of the reference measurement system for ct and lpcr characterization in presence of pq disturbances.

Show All

To develop the reference measurement system appropriating for PQM effectively and efficiently, improvements were made by incorporating the existing reference measurement systems[7], [8] from other EMRP or EMPIR projects, e.g., [9]. The bandwidth is up to 9 kHz. The algorithms for PQ generation and analysis have been integrated in the reference measurement system.

The self-developed LabView program [6] has seamlessly incorporated the algorithms for PQ generation. This program serves for controlling and expanding the arbitrary waveform generator. The algorithms are relied on the proposed PQ phenomena by IT4PQ project and realized superposition of multiple sinusoidal signals, amplitude / phase / frequency modulation and oscillation transient. The analogue transconductance power amplifiers (up to $270V_{rms}/70A_{rms}$, DC to 15 kHz) allows the generation of complex PQ test sequences that are programmed by the generator.

B. 2-Channel Voltage Ratio Measuring System and Uncertainty

For calibrations under PQ phenomena, a precise 2-channel voltage ratio measuring system, abbreviated as VRS [10], was applied. For a more comprehensive understanding of the uncertainties u_{VRS-PQ} of the 2-channel voltage ratio measuring system under PQ phenomena, a lowpass filter (LP filter) was designed and developed for characterization. The self-developed LP filter (cut-off frequency: about 12 kHz) was able to exhibit a stable frequency response similar to a reference CT and had linear behavior. The output of the LP filter was regarded as the DUT CT while the input was regarded as the reference CT. The frequency response of the LP filter was measured by single sinusoidal signals (100 mV, 1 V, and 5 V). Based on the results in Fig. 2 - a), the first uncertainty contribution u_{LP} regarding to the residual non-linearity of the LP filter were estimated from the calculated maximum deviations of the measured LP filter errors. Moreover, the second uncertainty contribution u_{PQ} was estimated from the error differences between the reference values $\underline{E}_N(f_n)$ and the measured values under PQ phenomena $\underline{E}_X(f_n)$, according to $\underline{E}_X(f_n) - \underline{E}_N(f_n)$. The measured results by 1 V input were regarded as the reference values $\underline{E}_N(f_n)$. Hence, the uncertainty u_{VRS-PQ} was calculated from both uncertainty contributions according to $u_{VRS-PQ} = \sqrt{(u_{LP}^2 + u_{PQ}^2)}$.

As a result, the uncertainties u_{VRS-PQ} at 50 Hz were within $\pm 6 \mu V/V$ and $\pm 5 \mu rad(k=1)$. Based on the ratio error's differences shown in Fig. 2, the uncertainties u_{VRS-PQ} at 9 kHz were within $\pm 155 \mu V/V$ and $\pm 275 \mu rad(k=1)$.

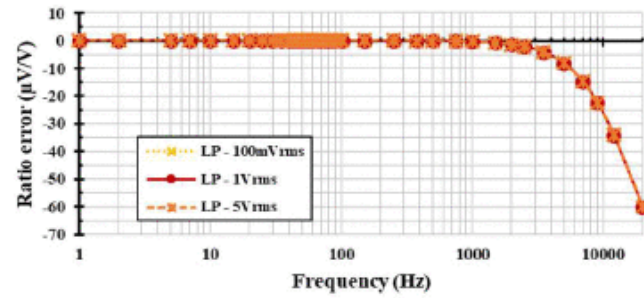

a) Frequency response and linearity of the LP filter for the ratio errors.

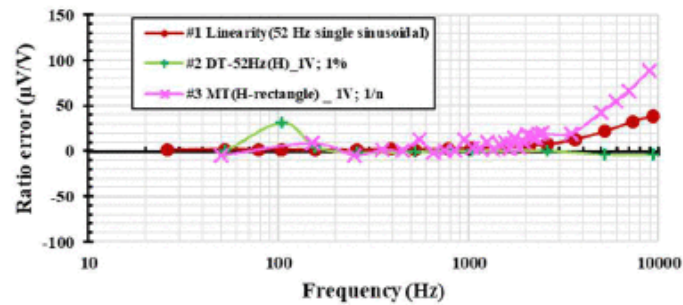

b) The wideband uncertainties of the 2-channel voltage ratio measuring system for the ratio errors obtained by using the LP filter. (#1 represents the result differences of the frequency response given by single-tone inputs of 100 mV, 1 V, and 5 V. #2 represents the results given by dual-tone harmonics: 1 V of the fundamental signal and 1 % of the harmonic signal. #3 represents the results given by multi-tone harmonics: 1 V of the fundamental signal and $1/n$ of the n^{th} harmonic signals.)

Fig. 2.

The wideband measurement results of a) the LP filter and b) the 2-channel voltage ratio measuring system.

Show All

C. Reference Ct and Uncertainties

The reference current sensors, e.g., CT200, adopted from the project 17IND06 “Future Grid II” [9] were evaluated using precision and wideband shunts Fluke A40B to characterize their performance under harmonics or interharmonics. The results for the ratio errors for instance are presented in Fig. 3. Consequently, the measurements uncertainties of CT200 under harmonics or interharmonics are estimated to be within $\pm 30 \mu\text{V/V}$ and $\pm 50 \mu\text{rad}$ ($k=1$). Compared to the uncertainties $U_{\text{MRS-PQ}}$ in section II-A, these uncertainties obtained by the CT200 can be conjectured as the uncertainties that caused by the 2-channel voltage ratio measuring system.

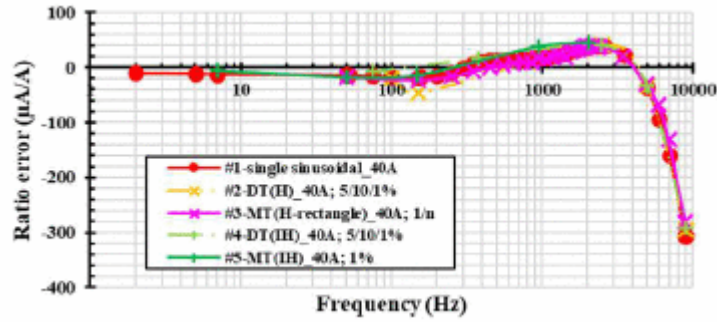

Fig. 3.

The frequency response of CT200 for the ratio errors and the ratio errors of CT200 under PQ harmonics / interharmonics. #1 represents the frequency response given by a single-tone of 40 A. #2 represents the errors given by dual-tone harmonics: $f_1=50$ Hz, $A_1=40$ A with $n=2(5\% \cdot A_1) / 3(10\% \cdot A_1) / 50(1\% \cdot A_1) / 100(1\% \cdot A_1) / 180(1\% \cdot A_1)$. #3 represents the errors given by multi-tone harmonics: 40 A of the fundamental signal and $1/n$ of the n^{th} harmonic signals, n is the odd number from 3 up to 179. #4 represents the errors given by dual-tone interharmonics $f_1=50$ Hz, $A_1=40$ A with $n=1.5(5\% \cdot A_1) / 7.5(10\% \cdot A_1) / 49.5(1\% \cdot A_1) / 99.5(1\% \cdot A_1) / 179.5(1\% \cdot A_1)$. #5 represents the errors given by multi-tone interharmonics: $f_1=50$ Hz, $A_1=40$ A with $n=7, 149, 951; 2048, A_n=1\% \cdot A_1$

Show All

D. Uncertainty Budget

The uncertainty u_{ref} of the reference measurement system for CTs under PQ phenomena consists of a basic uncertainty at 50 Hz and the wideband uncertainty under harmonic distortion (HD, $HD=A_n/A_1$) and is calculated by

$$u_{\text{ref}} = \sqrt{u_{\text{CTN}}^2 + u_{\text{RN}}^2 + u_{\text{VRS}}^2 + u_{\text{VRS-PQ}}^2} \quad (1)$$

with the corresponding individual uncertainty of the reference CTs u_{CTN} ; the reference measuring resistors u_{RN} the 2-channel voltage ratio measuring system u_{VRS} and the whole reference measurement system under PQ phenomena $u_{\text{VRS-PQ}}$. Each individual uncertainty was obtained by mathematical models based on actual measurement results. For instance, the uncertainty u_{PQ} is depend on the frequency f and the HD . A proposal of mathematical analysis for u_{PQ} is expressed as $u_{\text{PQ}}=a_1 \cdot f+a_0/HD$, where a_1 and a_0 are constant coefficients. As a result, based on the experimental results, $a_1=0.01 \cdot 10^{-6} \text{Hz}^{-1}$ for the ratio and phase errors' uncertainty and $a_0=1.2 \cdot 10^{-6}$ for the ratio errors' uncertainty and $a_0=2.6 \cdot 10^{-6}$ for the phase errors' uncertainty.

Table I. Standard uncertainties ($k = 1$) for the reference measurement system under PQ phenomena (HD = 1 %) at 9 khz.

	u_{CTN}	u_{RN}	u_{VRS}	$u_{\text{VRS-PQ}}$
For ratio errors (µA/A)	38	12	1	155
For phase errors (µrad)	205	113	2	275

As an initial result, the basic uncertainties from the reference measurement system under various PQ phenomena at the fundamental frequency are within $\pm 1 \cdot 10^{-5}$ for the ratio and phase errors ($k=1$). Besides, the characteristic measurement uncertainties from the reference measurement system under harmonics (HD=1 %) at 9 kHz are about $\pm 2 \cdot 10^{-4}$ for the ratio errors and $\pm 4 \cdot 10^{-4}$ for the phase errors ($k=1$).

Reference Measurement System for Vts

The reference generation and measurement system developed and characterized at INRIM is shown in Fig. 4. It can be used for the characterization of both VT and LPVT with primary voltage from 1 kV to ± 30 kV in presence of sinusoidal and arbitrary voltage waveforms with frequency content from DC up to 9 kHz. [11], [12]. In particular, a more complete metrological characterization is present in this paper, which introduces a specific analysis dealing with the impact of DC components on the measurement of inductive VTs harmonics ratio and phase errors, which has not been discussed in previous work.

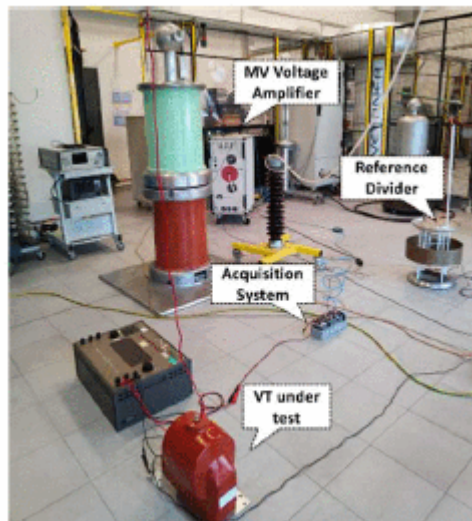

Fig. 4.

INRiM reference generation and measurement system for VT and LPVT characterization in presence of PQ disturbances.

The setup architecture can be divided into four main sections: Medium Voltage (MV) test waveforms are generated by an arbitrary waveform generator (AWG) coupled with a MV power amplifier. The reference sensor is a resistive-capacitive (RC) voltage divider specifically designed and built at INRIM for smart grid laboratory applications. The output voltages provided by the reference RC divider and the VT/LPVT under test are acquired by an acquisition system that includes various modules. The measurement and control software are developed in LabView and it provides a wide option of PQ phenomena to be generated. To prevent the generation of large step voltages, each test waveform is preceded and followed by a fade-in and a fade-out signal. Moreover, the generation and control software implement a real time DC compensation component, necessary when inductive VT are tested.

A. Characterization Tests

The four VT/LPVT reference measurement system sections have been characterized and a brief description and results are provided below.

Regarding the generation section, the Total Harmonic Distortion (THD) of the MV generation setup has been measured at various primary voltages. Specifically, the generation system has been configured to generate a pure sinusoidal waveform at 50 Hz with different primary voltage levels ranging from 2 kV to 15 kV. The first 100 spurious harmonic tones were evaluated to determine the THD. As a result, the measured THD has been found to be below 0.03% for all the tested voltages.

The accuracy of the reference RC divider has been evaluated through a series of tests including an assessment of the voltage dependence of the divider scale factor (SF), the frequency response, and stability and proximity tests at the rated frequency. The voltage dependence of the RC divider SF has been quantified both in DC and AC (50 Hz) by comparison with INRIM standard dividers and transformers from 1 kV to 20 kV. The measured SF variation is of $16 \mu\text{V}/\text{V}$ when the RC divider is supplied with DC voltages whereas $45 \mu\text{V}/\text{V}$ variation is observed under AC conditions. The frequency response is measured from 100 Hz to 9 kHz at reduced voltage (250 V) using a Fluke 5700 calibrator as reference. The frequency response of the ratio error exhibits a consistent flatness with a tolerance of $125 \mu\text{V}/\text{V}$ whereas the frequency response of phase error remains consistent within a range of $300 \mu\text{rad}$. As regard stability and proximity, they have an impact of few tens of ppm on both the RC divider ratio and phase errors.

The acquisition system has been calibrated under two different configurations, one adopted for the VT characterization (two channels of two different modules) and one for the LPVT (two channels of the same acquisition module). The characterization has been performed at several voltage levels and from 50 Hz to 9 kHz using as reference system a Fluke 5700 A comparator and a standard inductive voltage divider (CONIMED DI-7). Characterization results of two channels of NI 9239 board, used for testing LPVTs, are shown in Fig. 5.

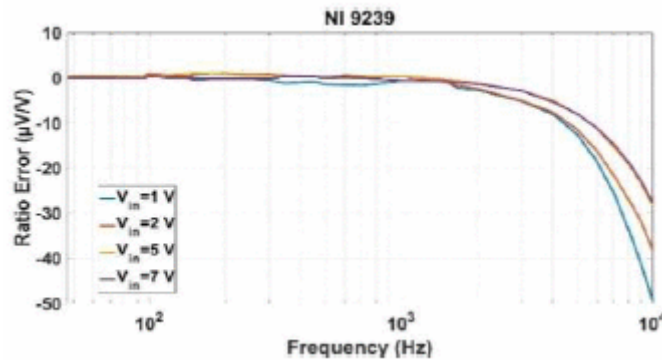

Fig. 5.

Ratio error between 2 channels of NI 9239 when they are used to test LPVTs.

A specific characterization test is performed to quantify the error contribution on harmonic ratio and phase errors due to the presence of a DC component superimposed to the voltage test signal. When an inductive VT is supplied with a signal consisting of a nominal 50 Hz voltage component and a small DC component, spurious harmonic tones are produced at the secondary side due to both the 50 Hz and DC components. These effects arise from the non-linearity of VT iron core. When an inductive VT is tested using a setup that does not involve step-up transformers, a small unintended DC component may be generated, even if it is not present in the actual test signal. This occurrence is due to the non-ideal behavior of the AWG and the MV amplifier. The presence of this DC component significantly affects the

estimation of harmonic ratio and phase errors by introducing additional spurious harmonic components. Unlike the spurious components generated by the fundamental frequency, this error is attributed to the generation system itself. As a result, it is necessary to compensate the DC and include its residual effect in the uncertainty budget. Fig. 6 shows the spurious harmonics at secondary side produced by a 20/√3 kV inductive VT when it is supplied at rated voltage and with three different DC values.

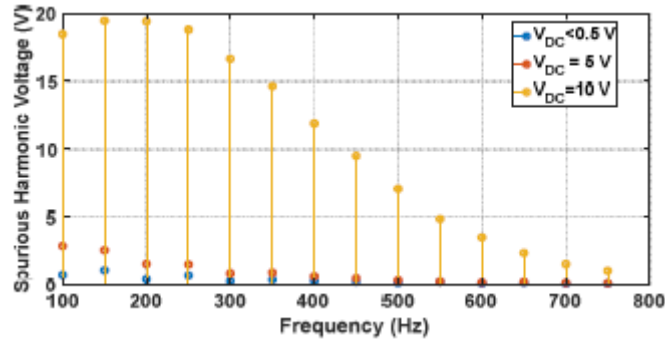

Fig. 6. Spurious harmonics at secondary side produced by an inductive VT when it is supplied at rated voltage and with three different DC values.

As can be observed, the higher is the DC component amplitude the higher are the spurious harmonics at VT secondary side, especially the first tones. Regarding the DC effect at 50 Hz, the ratio and phase errors measured in presence of the three DC values are reported in Table II.

Table II. Effect of DC components on ratio and phase errors at rated frequency

DC Value (V)	Ratio error (%)	Phase error (mrad)
<0.5	0.579	1.18
5	0.571	1.25
10	0.502	2.13

As can be observed, the 10 V DC presence have an impact of 770 $\mu\text{V}/\text{V}$ and 950 μrad for the ratio and phase errors measurement if compared to the DC<0.5 V case. When the 5 V case is considered, the differences decrease, in a nonlinear way, to 80 $\mu\text{V}/\text{V}$ and 70 μrad .

To quantify the impact of the spurious harmonics on the measurement of harmonics ratio and phase errors, the inductive VT is supplied with Fundamental plus 1 harmonic tone (FH1). The fundamental tone is set at rated amplitude and frequency and harmonic tone have amplitude equal to 1 %, 5 % and 10 % of the fundamental and frequency from 100 Hz to 500 Hz. Results related to the 10 V DC case are shown in Fig. 7, where the harmonic ratio error is expressed according to the following PQ performance index:

$$\varepsilon_h(\%) = 100 \cdot (k_r U_{s,h} - U_{p,h}) / U_{p,h} \quad (2)$$

where $k_r=U_{p,r}/U_{s,r}$ is the rated transformation ratio ($U_{p,r}$ and $U_{s,r}$ are the rated primary and secondary voltages at fundamental frequency) and $U_{p,h}$ and $U_{s,h}$ are the rms values of the primary and secondary h -order harmonic voltage.

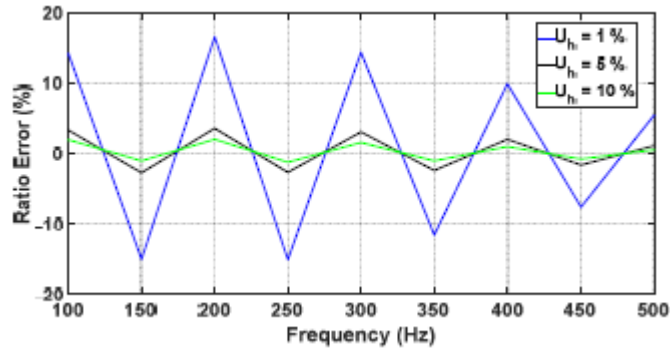

Fig. 7. Harmonics ratio error measured when the VT is supplied with FH1 test waveforms at three different harmonics amplitude and with 10 V DC values.

The effect is more predominant for lower harmonic amplitude and this is due to the increasing weight of spurious harmonic tones produced by the VT because of the DC tones.

Despite the DC compensation closed loop included into the generation software, there may still be a residual DC component present in the generated test voltage, albeit at a low level (below 0.5 V). This residual DC component impact on the measurement of ratio and phase errors. Consequently, its contribution is considered in the uncertainty budget, with the uncertainty component varying depending on the frequency and amplitude. The uncertainty associated with the residual DC component amounts to $15 \mu\text{V}/\text{V}$ and $15 \mu\text{rad}$ for power frequency ratio and phase error measurements, respectively. For the first harmonics when the amplitude of the harmonic test is set to 1%, the uncertainty contribution increases to $50 \mu\text{V}/\text{V}$ and $50 \mu\text{rad}$.

B. Uncertainty Budget

Considering all the characterization tests and the related results, this subsection presents the uncertainty budget associated to the ratio and phase error measurement from 5 kV to 20 kV and from 100 Hz to 9 kHz.

Table III. Ratio error standard uncertainty contributions from 5 kV to 20 kV and from 100 Hz to 9 kHz

Uncertainty Source	Standard Uncertainty ($\mu\text{V}/\text{V}$)
RCVD calibration	30
Voltage dependence	45
Frequency response	65
Proximity effect	21
Stability	6
Repeatability	5
Acquisition system	30
Residual DC component	50
Expanded uncertainty (level of confidence 95%): $210 \mu\text{V}/\text{V}$	

Table IV. Phase error standard uncertainty contributions from 5 kV to 20 kV and from 100 Hz to 9 kHz

Uncertainty Source	Standard Uncertainty (μrad)
RCVD calibration	30
Voltage dependence	16
Frequency response	150
Proximity effect	9
Stability	1
Repeatability	5
Acquisition system	38
Residual DC component	50
Expanded uncertainty (level of confidence 95%): 330 μrad	

Reference Measurement System for Combined Its

The measurement setup consists of generation and reference measurement parts. A block diagram used for the characterization of MV combined ITs and sensors, is shown in Fig. 8. Related literature reviews are [13], [14].

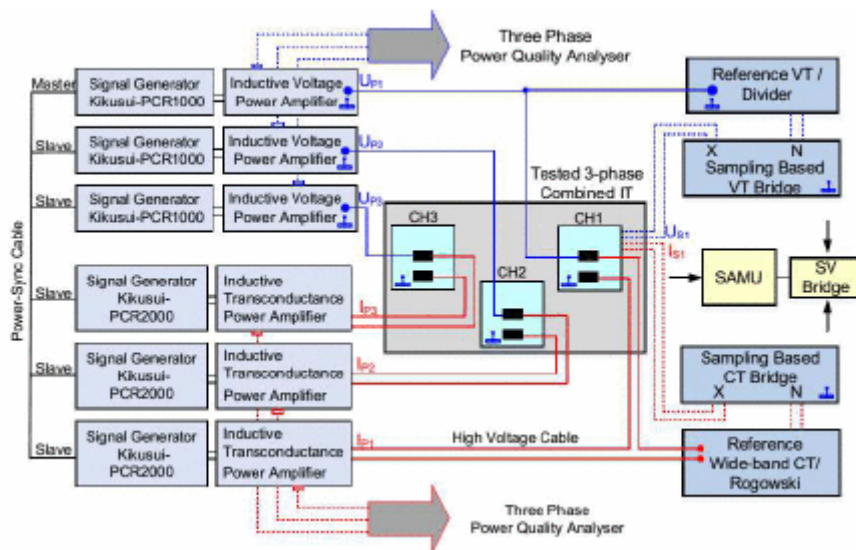

Fig. 8. Block diagram of the three-phase generation and measurement setup for testing MV combined ITs.

A. Generation of High Voltages and Currents

Generation of the three-phase (6-channels) setup includes the signal conditioning, power generation, high voltage and current amplification stages with feed-back control. Waveforms to be generated can be selected as sine-wave with steady-state harmonics and with other PQ parameters. And each channel can be configured individually for both amplitude and phase. Power generation is obtained by using 6 synchronized programmable linear power sources (Kikusui PCR series) with configurable power output ranges from 1 kW up to 6 kW. One master unit and its externally connected to the 5 slave units which are synchronized and it can be controlled either via front panel of the master unit or by using a computer. Voltage outputs (up to 300 V of fundamental) of these power sources are directly applied to the primary windings of 3 units of high voltage power amplifiers and to the primary windings of 3 units of high transconductance power amplifiers to obtain high voltages up to 36 kV and currents up to 2 kA, respectively. These high voltage and current amplifiers with inductive construction are equipped with individual wide-band measurement sensors, internally for feed-back control. In advance, each inductive transconductance amplifier has a feed-through window with an appropriate dimension to allow closed-link connection to MV connection, for safety.

B. Reference Measurement System

Two commercial bridges, one for VT and one for CT comparisons, are used for accuracy measurements for each channel while sampling-based wideband bridges and an analyzer with wideband reference current and voltage sensors are set for PQ measurements and analysis of influence factors such as proximity effects. This three-phase measurement setup allows simultaneous analysis of multiple external magnetic and electrical fields on each VT and CT of the tested three-phase combined IT. The reference measurement system is totally configurable for the testing of any type of ITs and sensors including the digital output ones with stand-alone merging units.

C. Traceability of the Voltage¤t It Measurements

Voltage IT measurements up to 200 kV level within power frequencies are traceable to national standards with typical uncertainties of $25 \mu\text{V}/\text{V}$ in ratio error measurements and $25 \mu\text{rad}$ for the phase displacement. A very well-known calibration method is applied for the calibration of reference voltage ITs used in the system by using LV and HV low-loss standard capacitors and an HV capacitance bridge.

Current IT measurements up to 5 kA (max. 10 kA) within power frequencies are traceable to national standards with typical uncertainties from $5 \mu\text{A}/\text{A}$ up to $50 \mu\text{A}/\text{A}$ in ratio measurements and with same values in μrad for phase. Reference current ITs used in the system are calibrated by following the step-up method based on the use of a multirange compensated current comparator.

Wideband characterization of reference ITs and sensors is typically based on the sampling ADCs, resistive dividers, current shunts, ac-dc transfer standards, and current comparators. Typical measurement uncertainties for steady-state PQ parameters are well within 200 ppm (and μrad) for up to 50th harmonics of voltages and currents.

D. System Characterization and Initial Tests

All required performance tests were performed which cover signal generation and conditioning, bandwidth and power limits of each source, synchronization criteria, amplifier types and their behavior in long-term operation such as stability and losses, isolation in cabling up to 36 kV, verification of bridges for sinusoidal and non-sinusoidal waveforms.

A set of test and calibration procedures was followed to analyze a number of criteria including stability, by using appropriate samples (MV ITs, combined ITs, and three-phase combined ones) with different voltage and current ranges. A picture of a testing setup for a three-phase combined IT sample is given in Fig. 9.

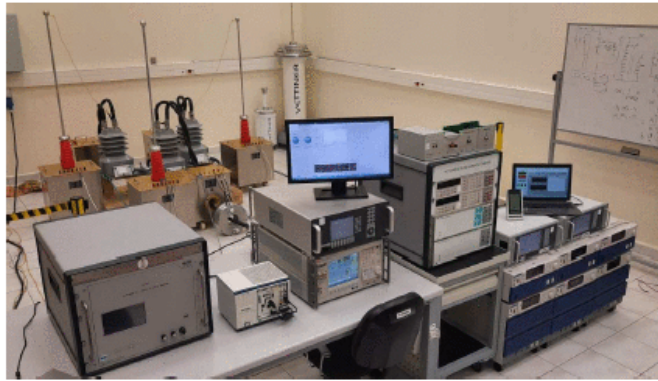

Fig. 9.

A sample 3-phase combined transformer while testing.

Initially, the voltage and current ITs of each phase of the combined IT were calibrated with the reference ITs by using commercial bridges and standard burdens. Secondly, each phase of the three-phase combined IT was re-calibrated simultaneously to see any deviations in their ratio and phase errors. Finally, simultaneous calibration of each phase was performed again while the other two phases were in operation mode with a typically 1200 phase difference between each other. Each test stage could be performed in high resolution with the steps of 0.01% of nominal value for both voltage and current amplitudes while the phase resolution is 0.001o for setting the phase difference between them and between each phase. The same approach was followed while performing PQ tests by using wide-band reference measurement units.

E. Uncertainty Budget

The standard uncertainties of CT measurement u_{xi} and VT measurement u_{xv} of combined ITs are calculated separately by (3) and (4) respectively for the measurements at 50 Hz and the wider frequencies up to 9 kHz:

$$u_{xi}^2 = u_x^2 + u_{ctref}^2 + u_{ctrefd}^2 + u_{ctbrg}^2 + u_{ctbrgd}^2 + u_{ctinf}^2 + u_{maginf}^2 + u_{elecinf}^2 + u_{prinf}^2 \quad (3)$$

$$u_{xv}^2 = u_x^2 + u_{vtref}^2 + u_{vtrefd}^2 + u_{vtbrg}^2 + u_{vtbrgd}^2 + u_{vtinf}^2 + u_{maginf}^2 + u_{elecinf}^2 \quad (4)$$

All uncertainty contributions regarding to the influences either for ratio error or phase displacement are already calculated to convert their sensitivity coefficients to 1. Repeatability u_x of CT and VT measurements, standard uncertainties of reference wide-band CT/Rogowski u_{ctref} , its annual drift $u_{ctref,d}$, reference VT/Divider u_{vtref} , its annual drift $u_{vtref,d}$, sampling based CT Bridge u_{ctbrd} , its annual drift $u_{ctbrd,d}$, VT bridge u_{vtbrd} , its annual drift $u_{vtbrd,d}$, influences of VT on CT measurements u_{ctinf} , influences of CT on VT measurements u_{vtinf} , magnetic field influence between adjacent phases u_{maginf} , electric field influence between adjacent phases u_{elcinf} , influence of primary cable alignment u_{prinf} . Measurement uncertainties of the ratio $u_x(\epsilon_i)$ and phase errors $u_x(\delta_i)$ are calculated with the similar parameters. Eventually, CT measurement uncertainties are determined $20 \mu A/A$ (and μrad) for 50 Hz while it varies up to $500 \mu A/A$ (and μrad) for above up to 9 kHz. VT uncertainties are 50 and 500 on the other hand.

Conclusion

A traceable reference measurement system for the CT calibrations under PQ phenomena has been presented. Each component of the reference measurement system as well as the complete reference measurement system has been successfully evaluated and validated. The expanded uncertainties of the reference measurement system under various PQ phenomena are determined to be $\pm 2 \cdot 10^{-5}$ for the ratio and phase errors at 50 Hz ($k=2$). Preliminary wideband expanded measurement uncertainties of the reference measurement system under harmonics at 9 kHz ($HD=1\%$) are about $\pm 4 \cdot 10^{-4}$ and $\pm 8 \cdot 10^{-4}$ ($k=2$).

A versatile setup for verifying the errors introduced by VT and LPVT in the measurement of PQ disturbances has been presented. A variety of PQ phenomena and their combinations are generated using an LV AWG coupled with an MV amplifier. To address challenges introduced by using an MV amplifier instead of a step-up transformer, a DC compensation loop has been implemented to mitigate potential spurious DC components. The residual effects are considered in the uncertainty budget.

A configurable calibration setup was developed for simultaneous measurement and testing of MV combined ITs and sensors, particularly on the three-phase combined ones. Performance tests of the complete system, verification of each reference measuring unit individually and validation of the measurement and test procedures were successfully completed. Several simultaneous tests are being performed on sample MV combined sensors.

Using the reference measurement system presented in this paper as a reference, more comparative measurements for the simplified industrial calibration methods are now on process. The comparative measurement results will likely be published at the conference as well as in the extended paper. Moreover, future work is required to perform PQ tests on the ITs with analogue and digital outputs.

ACKNOWLEDGMENT

The research described in this paper has been carried out in the framework of the 19NRM05 (IT4PQ) project. This project has received funding from the EMPIR programme (European Metrology Program for Innovation and Research) co-financed by the Participating States and from the European Union's Horizon 2020 research and innovation programme.

References

1.
P. Weidinger et al., "Need for a traceable efficiency determination method of nacelles performed on test benches", *Measurement: Sensors*, vol. 18, 2021.
2.
A. D. Femine, D. Gallo, C. Landi and M. Luiso, "Discussion on DC and AC Power Quality Assessment in Railway Traction Supply Systems", *2019 IEEE International Instrumentation and Measurement Technology Conference (I2MTC)*, pp. 1-6, 2019.
3.
European Metrology Networks / Smart Electricity Grids / Themes / Power Quality, May 2023.
4.
The IT4PQ website, Nov. 2019.
5.
G. Crotti et al., "Measurement Methods and Procedures for Assessing Accuracy of Instrument Transformers for Power Quality Measurements", *2020 Conference on Precision Electromagnetic Measurements (CPEM)*, pp. 1-2, 2020.
6.
Y. Chen, E. Mohns, M. Seckelmann and S. de Rose, "Traceable calibration system for non-conventional current sensors with analogue or digital output", *2021 IEEE 11th International Workshop on Applied Measurements for Power Systems (AMPS)*, pp. 1-6, 2021.
7.
G. Crotti, Y. Chen, H. Cayci, G. D'Avanzo, C. Landi, P. S. Letizia, et al., "How Instrument Transformers Influence Power Quality Measurements: A Proposal of Accuracy Verification Tests", *MDPI Sensors 2022*, vol. 22, no. 15, pp. 1-20, 2022.
8.
Y. Chen, A. Dubowik and E. Mohns, "Reference system for current sensor calibrations at power frequency and for wideband frequencies", *2022 20th International Conference on Harmonics and Quality of Power (ICHQP)*, pp. 1-6, May 29th - June 1st 2022.
9.
Metrology for the next-generation digital substation instrumentation - Euramet website [Online], June 2023.
10.
E. Mohns, J. Meisner, G. Roeissle and M. Seckelmann, "A Wideband Current Transformer Bridge", *IEEE Trans. Instrum. Meas.*, vol. 63, pp. 2322-2329, 2014.
11.
G. Crotti, G. D'Avanzo, P. S. Letizia and M. Luiso, "The Use of Voltage Transformers for the Measurement of Power System Subharmonics in Compliance With International Standards", *IEEE Transactions on Instrumentation and Measurement*, vol. 71, no. 9005912, pp. 1-12, 2022.
12.
G. Crotti et al., "Measurement of Dynamic Voltage Variation Effect on Instrument Transformers for Power Grid Applications", *2020 IEEE International Instrumentation and Measurement Technology Conference (I2MTC)*, pp. 1-6, 2020.
13.
H. Cayci, B. Ayhan and T. Kefeli, *An Improved Mobile Calibration Standard for Transformer Loss Measurement Systems*.
14.
D. Istrate et al., "Laboratory calibration of energy measurement systems (EMS) under AC distorted waveforms", *Sensors*, vol. 20, no. 21, pp. 6301, 2020.