



## ISTITUTO NAZIONALE DI RICERCA METROLOGICA Repository Istituzionale

A 10 V PJVS-based DC voltage realization at INRiM

*Original*

A 10 V PJVS-based DC voltage realization at INRiM / Durandetto, Paolo; Trinchera, Bruno; Serazio, Danilo; Enrico, Emanuele. - (2023), pp. 117-121. (Intervento presentato al convegno 26th IMEKO TC4 International Symposium 24th International Workshop on ADC/DAC Modelling&Testing tenutosi a Pordenone nel 20-21 September 2023).

*Availability:*

This version is available at: 11696/78119 since: 2023-11-08T13:35:50Z

*Publisher:*

*Published*

DOI:

*Terms of use:*

This article is made available under terms and conditions as specified in the corresponding bibliographic description in the repository

*Publisher copyright*

(Article begins on next page)

# A 10 V PJVS-based DC voltage realization at INRiM

Paolo Durandetto<sup>1</sup>, Bruno Trinchera<sup>1</sup>, Danilo Serazio<sup>1</sup>, Emanuele Enrico<sup>1</sup>

<sup>1</sup>INRiM - Istituto Nazionale di Ricerca Metrologica, Strada delle Cacce 91, Torino (Italy),  
 p.durandetto@inrim.it

**Abstract** – A 10 V DC quantum voltage calibration system, based on a programmable Josephson voltage standard (PJVS) operating in liquid helium, has been recently set-up and tested at INRiM. The PJVS system is partly-commercial and is based on a 10 V superconductor-normal metal-superconductor (SNS) array of 69631 Josephson junctions operated on the first Shapiro steps. The goal is to establish a new high-reliability quantum voltage standard for the DC calibration of solid-state voltage sources and digital voltmeters (DVMs). The paper reports the PJVS system description and first experimental testings and calibrations, preparatory to the future participation to international comparisons as final validation of the novel system.

## I. INTRODUCTION

Quantum-based voltage standards exploiting the inverse AC Josephson effect have been developed since the 1980s to either *reproduce* or *realize* the voltage unit (V) up to the 10 V level [1], and today are still under further improvement. Nowadays, turnkey systems based on Josephson voltage standards (JVSs) with both DC and AC capabilities are commercially-available and widespread within National Metrology Institutes (NMIs) and most-advanced calibration laboratories [2]. The first 10 V JVSs were based on SIS Josephson junctions (JJs) with insulating barrier and zero-current overlapping steps, which prevented them to be rapidly and easily programmed to generate the desired quantum voltage value. Also, quantum operating margins, i.e. the current-width of Shapiro steps, are generally lower than 50  $\mu\text{A}$ , thus proper filtering is required to prevent uncontrolled transitions between the overlapping voltage steps during calibrations. Despite this, SIS-JVSs are still operational at some NMIs as primary voltage standard, though are being gradually replaced by new-generation Programmable JVSs (PJVSs) [3]. These are based on SNS JJs with a single-valued current-voltage relation and quantum operating margins easily larger than 1 mA. Besides replacing SIS arrays as novel primary DC voltage standards, PJVS arrays can also be used for routine DC and AC voltage calibrations up to the kHz range with voltage resolution equal to the voltage generated by a single JJ, i.e. about 145  $\mu\text{V}$  at 70 GHz [4].

At Istituto Nazionale di Ricerca Metrologica (INRiM), we are setting up a 10 V DC quantum voltage calibration system based on a PJVS operating in liquid helium and driven at frequencies around 70 GHz. This paper presents the basic commercial 10 V DC PJVS system recently acquired from Supracon AG<sup>1</sup> and the further integration made at INRiM to make it fully operational. The basic PJVS system lacks of some features that are vital for a complete quantum-based DC voltage measurement system, in particular with regards to the calibration of DC voltage sources. Hardware and software components for covering this missing part have been developed in-house using existing commercial instrumentation and home-made equipment. These include a digital nanovoltmeter, a liquid helium (LHe) dewar, a home-made low-thermal manually-operated scanner, and a Python software for measurement acquisition and automated data analysis. The complete 10 V PJVS system is described below, along with first measurement characterizations and DC validation through the calibration of solid-state voltage standards.

## II. PJVS-BASED MEASUREMENT SYSTEM

In the following we report details about the main parts constituting the quantum voltage measurement system, which is shown in Fig. 1.

### A. 10 V PJVS device

PJVS arrays generate quantized voltages ( $V_{\text{PJVS}}$ ) through the current-controlled activation/deactivation of  $M$  sub-arrays, according to Eq. 1

$$V_{\text{PJVS}} = \sum_{i=1}^M N_{\text{JJ}}(i) n(i) K_{\text{J}}^{-1} f_{\text{rf}} \quad (1)$$

with  $N_{\text{JJ}}(i)$  the number of JJs in the  $i^{\text{th}}$  sub-array,  $n(i)$  the selected Shapiro step order of the  $i^{\text{th}}$  sub-array,  $K_{\text{J}}$  the Josephson constant, and  $f_{\text{rf}}$  the frequency of the applied microwave bias.

The PJVS device is a Supracon *almost*-binary array [5] with 69 631 SNS JJs. The N-layer is made of amorphous

<sup>1</sup>Brand names are used for identification purposes and such use implies neither endorsement by INRiM nor assurance that the equipment is the best available in the market.

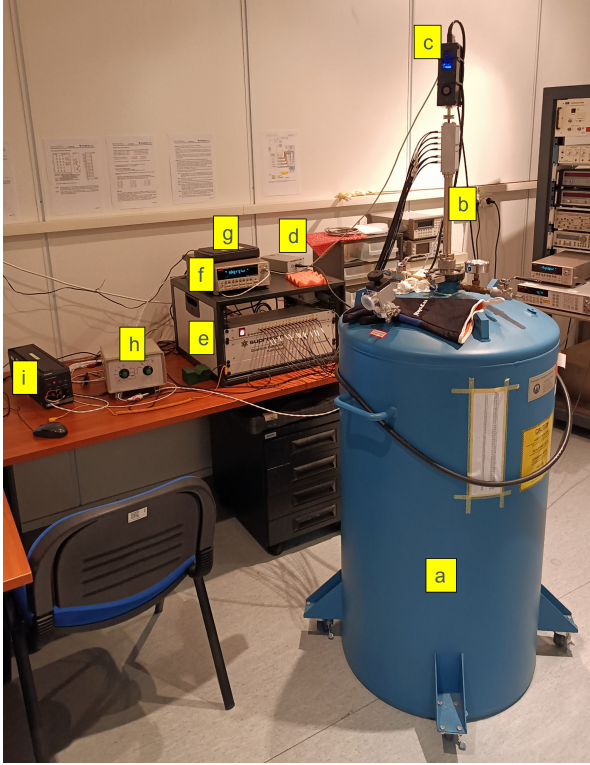

Fig. 1. Photograph of the 10 V PJVS-based measurement system. a) 60 L LHe dewar; b) Supracon cryoprobe immersed into the LHe, PJVS at the lower end and electrical connection box on the top side; c) 70 GHz synthesizer and d) power supply unit; e) rack with Supracon 18-channel bias source and floating power supply; f) Keithley 2182A nanovoltmeter; g) optically-isolated USB hub; h) low-thermal scanner; i) voltage source under calibration (Fluke 732B). Laptop not shown.

$\text{Nb}_x\text{Si}_{1-x}$ , trimmed for 70 GHz irradiation [6]. The PJVS main parameters are: critical current of 8.0 mA at 4.2 K;  $n = 0$  step width larger than 2 mA;  $n = \pm 1$  step width of 1.3 mA, centered at 9 mA. The array contains  $M = 17$  sub-arrays of series-connected JJs, each of which can be independently biased to a given Shapiro step. The array is structured with an almost-binary segmentation to limit the number of JJs required to reach the 10 V voltage target, that would be almost doubled with a true-binary segmentation [7]. The implemented array segmentation also enables to accurately verify the quantum operation with nV resolution.

### B. Cryogenic equipment

The PJVS chip is installed on the lower end of a cryoprobe and is magnetically shielded by a cryoperm can. The cryoprobe has been designed for operation with a 60 L LHe dewar. It is made of a low conductivity stainless steel tube and internally houses an oversized circular waveguide

for microwave transmission, as well as the wirings for sub-arrays bias and quantum voltage transfer. On the top side of the cryoprobe, an electrical connection box presents 17 SMB connectors for the sub-arrays biasing, a WR-12 flange for the microwave transmission, a 2-poles port for the Josephson voltage pick-up, and a 6-poles port for an additional quantum voltage pick-up and for biasing an integrated resistive heater mounted close to the PJVS chip, useful for quick JJ defluxing.

### C. Multi-channel bias source

The bias-current to drive each PJVS sub-array is provided by a 18-channel voltage generator built by Supracon AG. The main specifications of this bias source can be found in Ref. [8]. In our system, 17 out of the available 18 channels are used to drive the 17 sub-arrays.

To guarantee the PJVS array electrical isolation from the Earth ground, the Supracon system features a floating supply to power the 18-channels bias source. Moreover, the power supply is equipped with a second DC power source at 18 V suitable to energize the aforementioned defluxing heater by simply pushing a dedicated button on the front panel for few seconds. A USB galvanic isolator and a USB-optical hub are employed for isolating the PJVS array from ground as well as minimizing the number of USB-connections to the laptop.

### D. Microwave synthesizer

The required microwave power is provided by a commercial synthesizer<sup>2</sup> designed for 70 GHz Josephson voltage standards. The frequency range is 69.5 GHz to 70.5 GHz with 1 kHz resolution, whereas the maximum power level is about 250 mW, largely enough to drive common PJVS arrays. Frequency and power are set via software, and the synthesizer is USB-connected through the optical hub. The synthesizer comes with an external power supply unit (PSU), which can be in turn either DC or AC powered depending on the need. The synthesizer is equipped with a WR-12 flange for the 70 GHz signal output and a BNC input for the required 10 MHz reference time-base, which in our setup is provided by the INRiM Time and Frequency department.

### E. Nanovoltmeter / Null-detector

The Supracon basic PJVS system employs a commercial nanovoltmeter to perform the usual array performance tests, i.e. verification of critical current and quantum margins (Sec. F). Also, the same nanovoltmeter can be used as a null-detector for the calibration of voltage sources through a multi-step differential measurement strategy. In our system, a Keithley 2182A is employed for both functions, though a different high-accuracy null-detector, e.g.

<sup>2</sup>ELVA SYN-E-69.5-70.5

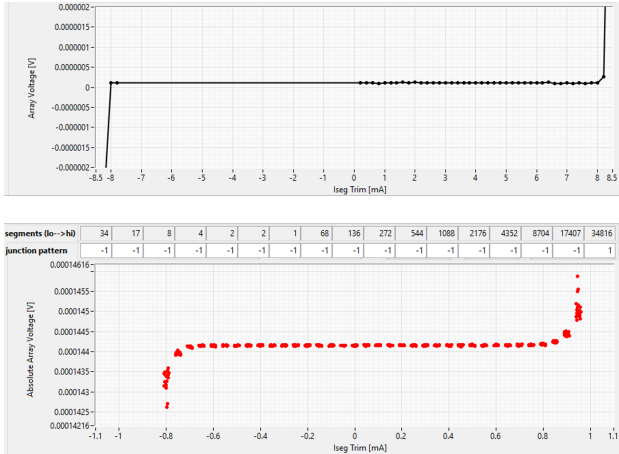

Fig. 2. PJVS array performance tests executed with the Supracon software. Top: plot of critical current test (no microwave). Bottom: plot of high-resolution quantum test with microwave at 69.65 GHz and 58 mW, set via the Supracon software, showing quantum margins larger than 1 mA.

an analog nanovoltmeter, may be employed for the calibration of voltage sources (Sec. G.) as well as to perform direct comparisons between Josephson voltage standards with ultimate accuracy [9].

#### F. Supracon software

The employed electronic instrumentation is properly software-controlled in order to automate both data acquisition and real-time analysis as much as possible. The purchased system comes with a closed-source basic software to control multi-channel bias source, microwave synthesizer and nanovoltmeter. Supracon software is employed to check the PJVS array performances, i.e. critical current, step width and quantum test (see Fig. 2), to automatically optimize microwave frequency and power, and to suitably current-drive the sub-arrays to produce the quantized voltage  $V_{PJVS}$  programmed via the user interface.

Supracon software also allows to perform the calibration of gain and non-linearity of a wide range of commercial digital voltmeters (DVMs), including the “internal” Keithley 2182A nanovoltmeter and the widespread Keysight 3458A digital multimeter. Gain factors of the internal nanovoltmeter are saved into a configuration file and exploited by Supracon software to correct the measured value for each nanovoltmeter range up to 10 V. Finally, the acquired Supracon software comes with a TCP option to enable it to be externally-controlled with another home-built computer application.

#### G. INRiM software

Supracon commercializes hardware and software tools for DC voltage source calibrations as an additional option to the purchased basic PJVS system. Hence, a software written in Python has been developed at INRiM to work together with the basic Supracon software: INRiM software extends the full system capabilities with a tool for the calibration of a voltage source through the implementation of differential measurement schemes exploiting the same Keithley 2182 nanovoltmeter employed by the Supracon software, but it also leaves open the possibility of using a different null-detector. INRiM software exploits the Supracon TCP option to indirectly control the PJVS to generate the required voltage levels  $V_{PJVS}$ , without the need of dealing with two separate graphical interfaces at the same time. Moreover, PJVS quantization can be further verified during the voltage source calibration by slightly trimming the PJVS bias currents, typically in steps of  $\pm 0.1$  mA. Finally, the INRiM software also enables internal nanovoltmeter gain correction using calibrated gain factors read from the Supracon software configuration file.

### III. CALIBRATION OF A DC VOLTAGE SOURCE

The implemented measurement system is illustrated in Fig. 3.

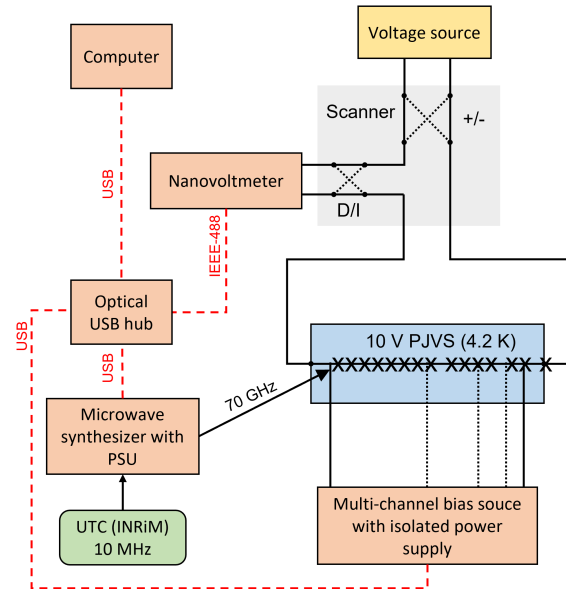

Fig. 3. Graphical representation of the 10 V PJVS system for the calibration of a DC voltage source through the differential measurement scheme.

At the current stage, a manual low-thermal electromotive forces (EMFs) scanner with both voltage source output polarity (+ or -) and nanovoltmeter input position (direct or

indirect) reversal capabilities is employed. In the future, a remotely-controlled scanner will be integrated in the system to fully automate and speed-up the calibration as well as to reduce possible heating effects related to the manual operation.

As customary, the calibration of a solid-state voltage standard requires the offsets cancellation in the measurement circuit, which are mostly due to thermal EMFs appearing between the PJVS array in LHe and the room temperature equipment. In a properly-designed measurement circuit, thermal offsets lower than  $1 \mu\text{V}$  are attained by using low Seebeck coefficient materials, by minimizing the number of connections and by reducing temperature gradients between the two equal branches of the closed loop. It is also worth to mention that the accurate knowledge of the thermodynamic temperature is not needed, but rather the overall thermal stability during the calibration is required. Besides thermal offsets, attention should also be paid to possible ground-loops or EMI-coupling effects, which may introduce additional systematic errors which depend on the null-detector polarity. To compensate for these possible systematic errors, the difference between PJVS and source voltages is measured in different circuit configurations using the low-thermal scanner and the reversal strategy. The PJVS polarity reversal does not require a physical switch and is easily accomplished through a dedicated software function. To avoid the nanovoltmeter overloading due to the non-simultaneous source and PJVS polarity reversals, the nanovoltmeter input is shorted prior to each voltage inversion and restored right after. Finally, in case of significant thermal EMFs variations, a proper calibration scheme can be implemented to cancel the contribution of offsets linearly changing with time, which consists in repeating the normal measurement sequence in the opposite way.

Preliminary calibration tests have been carried out to verify the correct operation of overall measurement system and employed procedures. The device under calibration was a Fluke 732B solid-state voltage source, with 1.018 V and 10 V nominal outputs. Microwave frequency and power were set to the optimal values attained with the Supracon software, i.e. 69.65 GHz and 56 mW. Two distinct calibration strategies have been adopted: i) a 4-steps sequence with both sources and nanovoltmeter reversals (+D, +I, -I, -D); ii) a faster 2-steps sequence with only sources polarity reversal (+D,-D), hence always keeping the null-detector switch in the direct mode (D). The calibration results at 10 V and 1.018 V nominal outputs are shown in Fig. 4. It can be seen that the measurements performed with the different polarity-reversals sequence are consistent within each other, therefore possible deviations related to the null-detector polarity are not significant.

Error bars represent the standard deviation of the mean of five repeated measurements. However, it is widely recognized that the calibration uncertainty of commercial

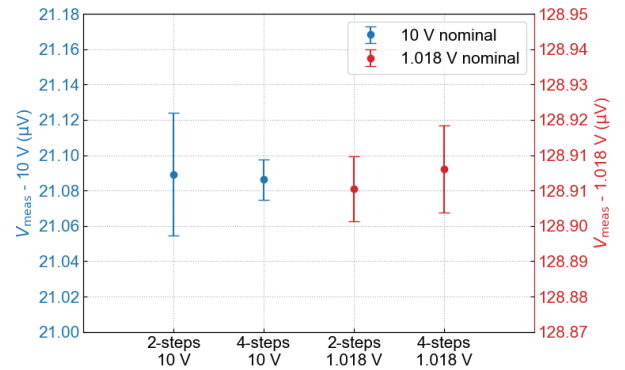

Fig. 4. Difference between source calibrated voltage and nominal voltage, at 10 V (left axis, blue) and 1.018 V (right-axis, red). Each voltage output has been calibrated following two distinct measurement schemes with either two (+D, -D) or four (+D, +I, -I, -D) reversal steps. Suppression of time-dependent offsets was not necessary. Error bars represent the standard deviation of the mean of five repeated measurements.

Zener-diode voltage references is dominated and limited by their inner flicker noise [10], which is likely to underestimate the actual random effects when the standard deviation of the mean is considered, especially for long measurement times. To account for the presence of the Zener flicker noise, a type-A uncertainty contribution not lower than 100 nV for the 10 V output is usually assumed [10]. With regards to type-B uncertainty contributions, these are associated to: i) null-detector gain and non-linearity; ii) uncompensated thermal offsets; iii) leakage resistances; iv) microwave frequency. A preliminary uncertainty budget, including both type-A and type-B sources, is shown in Tab. 1.

Uncertainty source	Uncertainty (nV)
<i>Type A</i>	
Noise (flicker)	150
<i>Type B</i>	
Nanovoltmeter	20
Uncompensated offsets	10
Leakage	< 1
Microwave frequency	< 0.1
<b>Combined standard uncertainty (<math>k=1</math>)</b>	<b>151.7</b>

Table 1. Preliminary uncertainty budget of the 10 V nominal output of the Fluke 732B calibrated with the PJVS system.

#### IV. CONCLUSION

A 10 V PJVS-based DC voltage calibration system has been recently purchased, integrated and tested at INRiM. It will serve as basis for the realization of the primary DC voltage standard linking the Italian voltage unit to the new quantum-based International System of Units. The optimal performances of the array have been verified. Also, actual quantization of PJVS-segments has been tested at the nV-level using the nanovoltmeter as null-detector. First calibration tests of a solid-state voltage source provide satisfactory results in terms of repeatability and overall uncertainty. Interlaboratory comparisons are foreseen to provide a final validation of the implemented quantum voltage measurement system.

#### REFERENCES

- [1] C. A. Hamilton, "Josephson voltage standards," *Rev. Sci. Instrum.*, vol. 71, no. 10, pp. 3611–3623, 2000.
- [2] B. Jeckelmann and B. Jeanneret, *The application of the Josephson and quantum Hall effects in electrical metrology*. IOS Press, 2007, vol. 166, pp. 135–179.
- [3] A. Rügenacht, N. E. Flowers-Jacobs, and S. P. Benz, "Impact of the latest generation of Josephson voltage standards in ac and dc electric metrology," *Metrologia*, vol. 55, no. 5, p. S152, 2018.
- [4] B. Trinchera, D. Serazio, P. Durandetto, L. Oberto, L. Fasolo *et al.*, "Towards a novel programmable Josephson voltage standard for sampled power measurements," in *Proceedings of 25th IMEKO TC4 International Symposium*. IMEKO, 2022, pp. 1–6.
- [5] F. Müller, T. J. Scheller, J. Lee, R. Behr, L. Palafox, M. Schubert, and J. Kohlmann, "Microwave design and performance of PTB 10 V circuits for the programmable Josephson voltage standard," *World J. Condens. Matter Phys.*, vol. 4, no. 03, p. 107, 2014.
- [6] F. Müller, T. Scheller, R. Wendisch, R. Behr, O. Kieler, L. Palafox, and J. Kohlmann, "NbSi barrier junctions tuned for metrological applications up to 70 GHz: 20 V arrays for programmable Josephson voltage standards," *IEEE Trans. Appl. Supercond.*, vol. 23, no. 3, pp. 1 101 005–1 101 005, June 2013.
- [7] P. Durandetto and A. Sosso, "Non-conventional PJVS exploiting first and second steps to reduce junctions and bias lines," *IEEE Trans. Instrum. Meas.*, vol. 69, no. 4, pp. 1294–1301, 2020.
- [8] M. Starkloff, H. Preissler, and M. Schubert, "Compact 18-channel bias source for 10 V programmable Josephson voltage standard arrays," in *2020 Conf. Precis. Electromagn. Meas. (CPEM)*. IEEE, 2020, pp. 1–2.
- [9] A. Rügenacht, Y. Tang, S. Solve, A. E. Fox, P. D. Dreselhaus, C. Burroughs, R. E. Schwall, R. Chayramy, and S. Benz, "Automated direct comparison of two cryocooled 10 volt programmable Josephson voltage standards," *Metrologia*, 2018.
- [10] R. Chayramy, S. Yang, O. Power, and S. Solve, "Metrology of zener-based secondary voltage standards," *Meas. Sci. Technol.*, vol. 32, no. 10, p. 105019, 2021.