



ISTITUTO NAZIONALE DI RICERCA METROLOGICA Repository Istituzionale

Recent Results on a Rb Pulsed Optically Pumped Clock for Space Applications

This is the author's accepted version of the contribution published as:

Original

Recent Results on a Rb Pulsed Optically Pumped Clock for Space Applications / Micalizio, S.; Gozzelino, M.; Calosso, C. E.; Levi, F.; Belfi, J.. - (2023). (Intervento presentato al convegno Joint Conference of the European Frequency and Time Forum and IEEE International Frequency Control Symposium tenutosi a Toyama, Japan nel 15-19 May 2023) [10.1109/EFTF/IFCS57587.2023.10272043].

Availability:

This version is available at: 11696/79580 since: 2024-06-07T13:02:41Z

Publisher:

Published

DOI:10.1109/EFTF/IFCS57587.2023.10272043

Terms of use:

This article is made available under terms and conditions as specified in the corresponding bibliographic description in the repository

Publisher copyright

IEEE

© 20XX IEEE. Personal use of this material is permitted. Permission from IEEE must be obtained for all other uses, in any current or future media, including reprinting/republishing this material for advertising or promotional purposes, creating new collective works, for resale or redistribution to servers or lists, or reuse of any copyrighted component of this work in other works

(Article begins on next page)

Recent Results on a Rb Pulsed Optically Pumped Clock for Space Applications

S. Micalizio

Quantum Metrology and Nanotechnologies Division, INRIM, Torino, Italy

M. Gozzelino

Quantum Metrology and Nanotechnologies Division, INRIM, Torino, Italy

C.E. Calosso

Quantum Metrology and Nanotechnologies Division, INRIM, Torino, Italy

F. Levi

Quantum Metrology and Nanotechnologies Division, INRIM, Torino, Italy

J. Belfi

Atomic Clocks, Leonardo SpA, Milan, Italy

Abstract:

We report on the recent characterization of a Rb microwave clock based on the pulsed optical pumping (POP) principle. The clock is developed in the frame of a INRIM-Leonardo collaboration intended to implement a highly stable and compact device for space applications. The physics package developed by Leonardo S.p.A. includes space-graded components, weights less than 4 kg and occupies only a 4-liters volume. It has been characterized with custom optics and electronics developed at INRIM laboratories. By taking advantage of advanced stabilization techniques for the laser and microwave pulses, this arrangement exhibits state-of-the-art short- and mid-term stability, reaching $\sigma_y(40000s) = 6 \times 10^{-16}$ (drift removed) for a 200000s run.

Author Keywords

- rubidium,
- atomic clocks,
- telecom,
- GNSS

Introduction

Vapor-cell clocks based on a hot rubidium vapor are at the basis of many time-keeping applications, including modern global navigation satellite systems (GNSS) and telecommunications. These devices demonstrated to be reliable, robust and compact and are able to deliver a stable signal for one day of integration time or longer [1]. However, more recently, laser-pumped cell clocks have demonstrated improved stability performances compared to traditional lamp-pumped devices, maintaining at the same time the potential of reduced size weight and power consumption (SWaP) [2]–[6].

As a drawback, the simultaneous presence of laser and microwave signals during the clock interrogation introduces a rather high sensitivity of the clock frequency to the laser parameters (namely frequency and intensity). The pulsed approach allows to relax the specifications on the laser noise and stability, since the clock state spectroscopy is

performed in the dark [7]. Nevertheless, due to experimental limitations (i.e. available pumping power, and not ideal extinction of the light during the Ramsey time), a residual sensitivity to the laser parameter remains. Moreover, coherent noise transfer from the laser remains mainly during the optical detection [8]. Thus, careful engineering of the laser pulses has proven to be crucial for obtaining the best clock performance [7].

Here, we present the most recent results obtained with advanced pulses-stabilization techniques. The results were obtained with an engineered physics package developed by Leonardo S.p.A. targeting the space market.

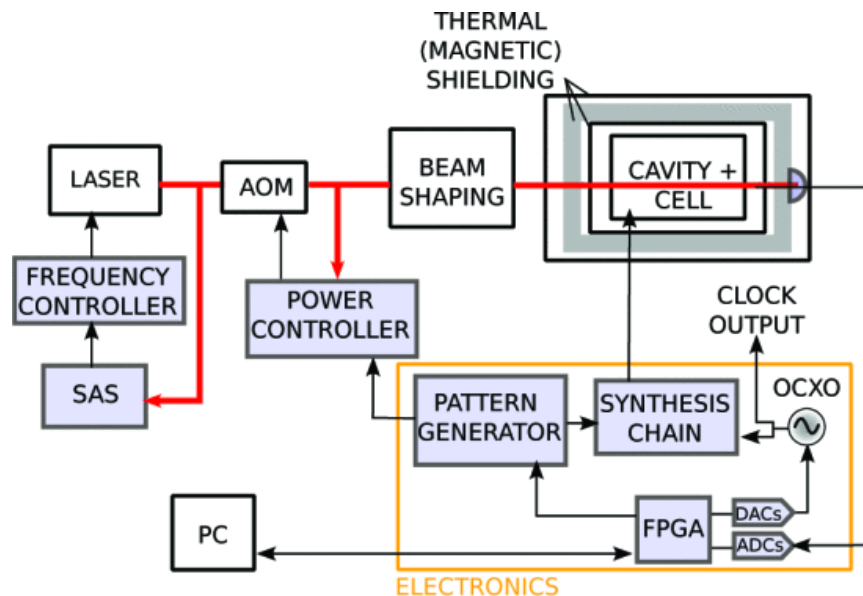

Fig. 1.

Functional scheme of the laser-pumped Rb-POP clock. The laser diode used for optical pumping and atomic-state detection is frequency stabilized on an external spectroscopy setup. The main output is sent to a fiber coupled acousto-optic modulator (AOM). The diffracted beam mode is cleaned and expanded by means of an optical fiber patch and free-space optics. Finally, it is delivered to the clock physics package. The AOM acts as an optical switch for generating the pulses and also for reducing the intensity noise of the laser. The power controller is driven by the same custom digital-electronics package that is used for controlling the experiment. SAS: Saturation Absorption Setup. OVCXO: Oven-controlled Crystal Oscillator. FPGA: Field-programmable Gate Array. DAC: Digital-to-Analog Converter. ADC: Analog-to-digital Converter.

[Show All](#)

Clock setup and results

The clock setup is composed of a laser source, a physics package, a low-noise synthesis chain to generate the coherent microwave pulses and a digital electronics to manage the clock operation (see Figure 1).

The laser source is a DFB laser diode emitting at 780.24nm. The laser pulses are generated by an active controller driving an acousto-optic modulator (AOM); in this way, it is possible to produce laser pulses of programmable length and amplitude. The controller has enough bandwidth to reduce the laser relative intensity noise (RIN) in a range of Fourier frequencies of interest for the clock signal processing (from 100Hz to tens of kHz). On the other hand, for long averaging times, the controller stabilizes the pulses amplitude. The laser frequency is stabilized using a reference cell containing only a Rb vapor by means of saturated-absorption technique. The amplitude of the microwave pulses is also actively stabilized,

using the technique depicted in [9]. Both laser and microwave amplitudes are stabilized with relative stability below 5×10^{-4} . The physics package is an engineered model developed by Leonardo S.p.A. in the framework of an European Space Agency (ESA) General Support Technology Program (GSTP) [10]. The prototype has been already tested for vibrations, shock and has been also characterized in terms of thermal and magnetic sensitivity.

The electronics includes the microwave synthesis chain and the digital electronics needed for low-noise signal acquisition. It has been extensively described in [11].

The clock operates in a Ramsey mode. After optical pumping, the atoms interact with a couple of microwave pulses according to the Ramsey scheme. Finally, a second laser pulse probes the atoms that have made the clock transition.

When the local oscillator is frequency locked on the atomic reference signal, we obtained the frequency stability results showed in Figure 2. We measured a white-noise-limited frequency stability of $1.2 \times 10^{-13} \tau^{-1/2}$ up to 1000 s of averaging time. By selecting a 200000s long run under quite environmental conditions, it achieves the values of 6×10^{-16} for integration times of 40000 s (drift removed). These are, to our knowledge, record results for a vapor cell frequency standard.

The complete implementation of this new technology at the industrial level is expected to match GNSS requirements and to provide advantages reducing in orbit maintenance needs, increasing re-alignment intervals with a simultaneous reduction of size, mass and power consumption while providing frequency stability performances competitive with the passive hydrogen maser.

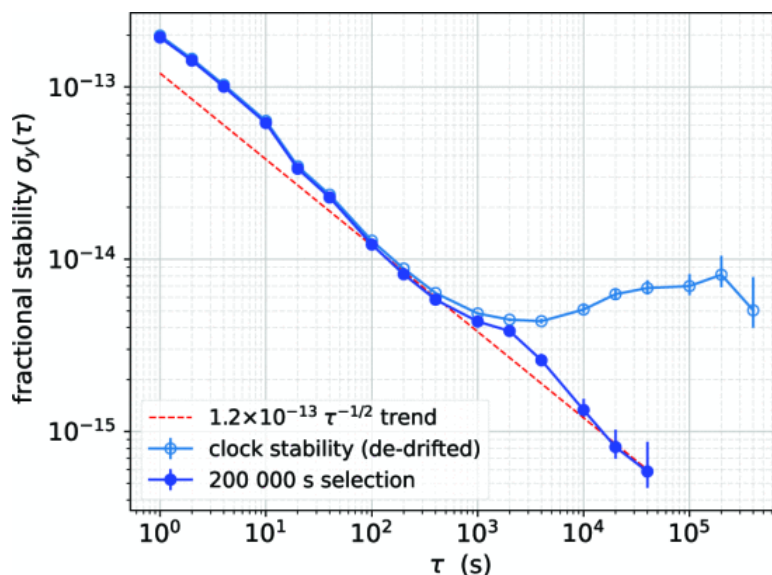

Fig. 2. Stability of the POP clock described in the text when measured with a stable hydrogen maser as a reference. Measurement bandwidth 5 Hz. A linear drift of $3.9 \times 10^{-14}/d$ is removed from the whole measurement.

Show All

Acknowledgment

We thank M. Belloni for fruitful discussions. This work was partially funded under ESA GSTP contract (Element 2) with Leonardo S.p.A. as prime.

References

1. B. Jadusziwer and J. Camparo, "Past present and future of atomic clocks for GNSS", *GPS Solutions*, vol. 25, jan 2021.
2. T. Bandi, C. Affolderbach, C. Stefanucci, F. Merli, A. K. Skrivervik and G. Mileti, "Compact high-performance continuous-wave double-resonance rubidium standard with $1.4 \times 10^{-13} \tau^{-1/2}$ stability", *IEEE Transactions on Ultrasonics Ferroelectrics and Frequency Control*, vol. 61, pp. 1769-1778, nov 2014.
3. P. Yun, Q. Li, Q. Hao, G. Liu, E. de Clercq, S. Guérandel, et al., "High-performance coherent population trapping atomic clock with direct-modulation distributed bragg reflector laser", *Metrologia*, vol. 58, pp. 045001, jul 2021.
4. N. Almat, M. Gharavipour, W. Moreno, F. Gruet, C. Affolderbach and G. Mileti, "Long-term stability analysis toward $< 10^{-14}$ level for a highly compact POP rb cell atomic clock", *IEEE Trans. Ultrason. Ferroelect. Freq. Contr.*, vol. 67, pp. 207-216, jan 2020.
5. M. A. Hafiz, G. Coget, M. Petersen, C. E. Calosso, S. Guérandel, E. de Clercq, et al., "Symmetric autobalanced ramsey interrogation for high-performance coherent-population-trapping vapor-cell atomic clock", *Applied Physics Letters*, vol. 112, pp. 244102, jun 2018.
6. Q. Hao, W. Xue, W. Li, F. Xu, X. Wang, W. Guo, et al., "Microwave pulse-coherent technique-based clock with a novel magnetron-type cavity", *IEEE Trans. Ultrason. Ferroelect. Freq. Contr.*, vol. 67, pp. 873-878, apr 2020.
7. S. Micalizio, F. Levi, C. E. Calosso, M. Gozzelino and A. Godone, "A pulsed-laser Rb atomic frequency standard for GNSS applications", *GPS Solutions*, vol. 25, apr 2021.
8. C. E. Calosso, M. Gozzelino, A. Godone, H. Lin, F. Levi and S. Micalizio, "Intensity detection noise in pulsed vapor-cell frequency standards", *IEEE Trans. Ultrason. Ferroelect. Freq. Contr.*, vol. 67, pp. 1074-1079, may 2020.
9. M. Gozzelino, S. Micalizio, F. Levi, A. Godone and C. E. Calosso, "Reducing cavity-pulling shift in ramsey-operated compact clocks", *IEEE Transactions on Ultrasonics Ferroelectrics and Frequency Control*, vol. 65, pp. 1294-1301, jul 2018.
10. P. Arpesi, J. Belfi, M. Gioia, N. Marzoli, R. Romani, A. Sapia, et al., "Rubidium pulsed optically pumped clock for space industry", *2019 Joint Conference of the IEEE International Frequency Control Symposium and European Frequency and Time Forum (EFTF/IFC)*, apr 2019.
11. C. E. Calosso, M. Gozzelino, E. Bertacco, S. Micalizio, B. Francois and P. Yun, "Generalized electronics for compact atomic clocks", *2017 Joint Conference of the European Frequency and Time Forum and IEEE International Frequency Control Symposium (EFTF/IFC)*, jul 2017.