



ISTITUTO NAZIONALE DI RICERCA METROLOGICA Repository Istituzionale

A cryogenic sapphire resonator oscillator with 10 – 16 mid-term fractional frequency stability

Original

A cryogenic sapphire resonator oscillator with 10 – 16 mid-term fractional frequency stability / Fluhr, C., Dubois, B., Calosso, C.E., Vernotte, F., Rubiola, E., Giordano, V.. - In: APPLIED PHYSICS LETTERS. - ISSN 0003-6951. - 123:4(2023). [10.1063/5.0153711]

Availability:

This version is available at: 11696/80639 since: 2024-03-13T13:07:25Z

Publisher:

American Institute of Physics

Published

DOI:10.1063/5.0153711

Terms of use:

This article is made available under terms and conditions as specified in the corresponding bibliographic description in the repository

Publisher copyright

AIP

This article may be downloaded for personal use only. Any other use requires prior permission of the author and AIP Publishing. This article may be found at DOI indicated above.

(Article begins on next page)

RESEARCH ARTICLE | JULY 28 2023

A cryogenic sapphire resonator oscillator with 10^{-16} mid-term fractional frequency stability

C. Fluhr ; B. Dubois ; C. E. Calosso ; F. Vernotte ; E. Rubiola ; V. Giordano  



Appl. Phys. Lett. 123, 044107 (2023)

<https://doi.org/10.1063/5.0153711>



CrossMark

Boost Your Optics and Photonics Measurements

Lock-in Amplifier

Zurich Instruments

[Find out more](#)

Boxcar Averager

A cryogenic sapphire resonator oscillator with 10^{-16} mid-term fractional frequency stability

Cite as: Appl. Phys. Lett. **123**, 044107 (2023); doi: [10.1063/5.0153711](https://doi.org/10.1063/5.0153711)

Submitted: 11 April 2023 · Accepted: 6 July 2023 ·

Published Online: 28 July 2023



View Online



Export Citation



CrossMark

C. Fluhr,¹  B. Dubois,¹  C. E. Calosso,²  F. Vernotte,³  E. Rubiola,^{2,3}  and V. Giordano^{3,a)} 

AFFILIATIONS

¹Femto Engineering, 15B Avenue des Montboucons, 25030 Besançon Cedex, France

²Physics Metrology Division, Istituto Nazionale di Ricerca Metrologica INRiM, Torino, Italy

³FEMTO-ST Institute, Dpt. TF, Centre National de la Recherche Scientifique, 26 Ch. de l'Épitaphe, 25000 Besançon, France

^{a)}Author to whom correspondence should be addressed: giordano@femto-st.fr

ABSTRACT

We report in this Letter the outstanding frequency stability performance of an autonomous cryogenic sapphire oscillator (CSO) presenting a flicker frequency noise floor below 2×10^{-16} near 1000 s of integration time and a long-term Allan deviation limited by a random walk process of $\sim 1 \times 10^{-18} \sqrt{\tau}$. The frequency stability qualification at this level called for the implementation of sophisticated instrumentation associated with ultra-stable frequency references. This result is technologically sound as it demonstrates the potentiality of the CSO technology. From the physical point of view, it sets an upper limit to the ultimate noise floor of the cryogenic microwave resonator that is competitive to that of the ultra-stable optical Fabry–Pérot cavities.

Published under an exclusive license by AIP Publishing. <https://doi.org/10.1063/5.0153711>

Tests of fundamental physics,^{1–4} radioastronomy,^{5,6} and fundamental and applied metrology^{7,8} make an extensive use of ultra-stable frequency sources, for which there is a constant demand for improved frequency stability performance for the measurement time ranging from 1 to 10^6 s. Atomic frequency standards are, of course, preferred when accuracy and long-term frequency stability are required. However, even in this case, an ultra-stable signal source based on a high Q-factor macroscopic resonator is needed to reach the ultimate frequency stability of the atomic clock.^{9–11} These secondary references, which are not based on the observation of an atomic resonance, are built around an ultrasonic quartz resonator for the radio-frequency (RF) and very-high-frequency (VHF) band, a dielectric resonator for microwaves, or a Fabry–Pérot cavity for optics. The macroscopic resonator can be integrated directly in the loop of a self-sustained oscillator or used as a passive reference on which a flywheel oscillator is stabilized. The high Q-factor and the power-handling capability of the macroscopic resonator guarantee a high short-term frequency stability. However, at mid- and long-term, i.e., for the integration time ranging from 10 s to few days, the oscillator frequency stability is degraded by the fluctuations of the resonator natural frequency.

The design of a signal source with the highest frequency stability in the widest integration time range is challenging. Indeed, we have to manage a great number of perturbation sources impacting the frequency stability at different integration times. The means of

overcoming all these disturbances are often contradictory between them, and thus, tradeoffs have to be found. For example, increasing the signal power increases the signal to noise ratio and thus is favorable for the short term frequency stability. However, it can also induce a resonator non-linearity, which makes the resonant frequency sensitive to the signal amplitude,^{12–14} thus will impact the long-term frequency stability.

The metrological aspect is also very challenging when we have to optimize and qualify a new type of ultra-stable source. If a better reference is not available, two almost identical units have to be implemented and compared. As it is impossible to ensure that each signal source contributes equally to the observed frequency fluctuations, the measured result gives only an overestimated Allan deviation (ADEV). If an improvement is made to one unit, its impact on the measurement result can be hidden by fluctuations of the other source. A more efficient way to get the intrinsic frequency stability of the oscillator to be qualified is to apply the three-cornered-hat (TCH) method or the covariance method.¹⁵ The price to be paid is the need of two other signal sources with comparable performances. These methods have actually been used for several types of ultra-stable oscillators,^{16–18} providing a better understanding of the main frequency stability limitations. However, the TCH or covariance methods fail when correlations exist between two of the signal sources that are compared, giving non-realistic variances. One of the major issues

comes from mid- or long-term environment fluctuations that could induce such correlations.

The cryogenic sapphire oscillator (CSO) is an autonomous microwave oscillator able to meet the requirements for many very demanding applications. All our resonators are made of high-purity sapphire monocrystal (Al_2O_3) shaped as a cylinder of 54 mm-diameter and 30 mm-high, cooled down near the liquid helium temperature. This resonator operates in the quasi-transverse magnetic whispering-gallery mode $\text{WGH}_{15,0,0}$ at $\nu_0 = 9.99$ GHz. The resonant frequency shows a turnover temperature T_0 for which the resonator sensitivity to temperature variations nulls at the first order. The appearance of this turning point results from the presence of a small amount of paramagnetic impurities as Cr^{3+} or Mo^{3+} and is specific to each resonator. The CSO is a Pound-Galani oscillator: The resonator is used in the transmission mode in a regular oscillator loop and in the reflection mode as the discriminator of the classical Pound servo. The sustaining stage and the control electronics are placed at room temperature. The CSO output at ν_0 drives the frequency synthesizer, which delivers several output frequencies: 10 GHz, 100 MHz, and 10 MHz in the typical implementation. The synthesizer can be disciplined at long term on an external 100 MHz signal coming from a hydrogen maser (HM), for example.

The first CSO generation incorporating a 6 or 8 kW cryocooler as the cold source, demonstrated an ADEV $\sigma_y(\tau) < 1 \times 10^{-15}$ for $1 \text{ s} \leq \tau \leq 10\,000 \text{ s}$ with $< 1 \times 10^{-14}/\text{day}$ drift.^{19,20} In these CSOs, we implemented sapphire crystals obtained with the heat exchanger or Kyropoulos method of growth. T_0 is found between 5.8 and 6.3 K.

A second CSO generation, code-named ULISS-2G, consuming only a 3 kW single phase is now commercially available. The conservative ADEV specification of ULISS-2G is as follows: $\sigma_y(\tau) \leq 3 \times 10^{-15}$ for $1 \text{ s} \leq \tau \leq 10\,000 \text{ s}$ and better than 1×10^{-14} over one day.²¹ To achieve the low consumption objective, the cryostat was totally redesigned and the technical solutions we implemented are detailed in a previous publication.²² The results presented in Ref. 22 have been obtained with a Kyropoulos resonator with $T_0 = 5.2$ K. We already build, validated, and delivered five ULISS-2G CSOs to different international metrological institutes.²³ The sixth unit has been operating for the first time in March 2022. These six units are nearly identical in design and implementation. The instrument is shown in Fig. 1. They incorporate sapphire crystals obtained with the top seeded melt growth method. A noticeable difference with our previous implementations is the resonator turnover temperature found here between 6.2 and 7.5 K. This is not anecdotal because the material heat capacity and thermal conductance as well as the resonator residual thermal sensitivity vary significantly between 5 and 8 K. We demonstrate in Ref. 24 that the lowest T_0 is advantageous for the short-term frequency stability. Indeed, the temperature control is more efficient: lower resonator sensitivity, smaller time constants, and higher sensitivity of the temperature sensor.

Although its design is identical to the previous machines, the last and sixth unit, code-named U10, showed improved performances from the first tests. In this Letter, we report on the frequency stability characterization of this new CSO between 1 s and about 3 days, with an improved measurement resolution compared to previous stability measurements. The U10 ADEV is below 2×10^{-16} between 100 and 10^4 s.

For the measurements described here, U10 was implemented in the laboratory workshop equipped only with the standard air-



FIG. 1. View of the CSO. The cryostat is integrated at the bottom of a 19 in. rack supporting also the frequency synthesis and the control electronics.

conditioning system of a flat. Depending on the sunlight, the temperature near the cryostat can vary of several degrees during the day. Moreover, the workshop is in free access for laboratory staffs, and this makes it impossible to maintain an undisturbed ambient for the duration of the measurement (few days).

The accurate qualification of U10 between 1 s and about 3 days has been made possible by the availability of a multichannel real-time phasemeter designed by one of the authors.²⁵ This instrument, i.e., the Time Processor, is based on the Tracking Direct Digital Synthesizer (TDDS) technology. In short, a dedicated direct digital synthesizer (DDS) is phase-locked to each input signal and the phase information of the input with respect to the local oscillator is extracted from the phase-control word. The data are normalized to phase time, so that channels at different frequencies can be compared directly. The newly implemented version of the Time Processor is able to compare together up to 16 independent signal sources or beatnotes at different frequencies. Each input is characterized by an acquisition and lock range of 5–400 MHz, and a cutoff frequency (f_H) of 5 Hz. The one channel resolution in terms of Allan Deviation (ADEV) is $\sigma_y(\tau) = 1.7 \times 10^{-14}/\tau$ ($2.1 \times 10^{-14}/\tau$) for a 100 (10) MHz input carrier. This limitation is set by the intrinsic phase noise of the DDSs. The measurement setup is schematized in Fig. 2.

To perform our measurements, we used the RF and microwave ultra-stable references available in our laboratory: a set of three hydrogen masers (HMs), as well as a set of three high-performance first

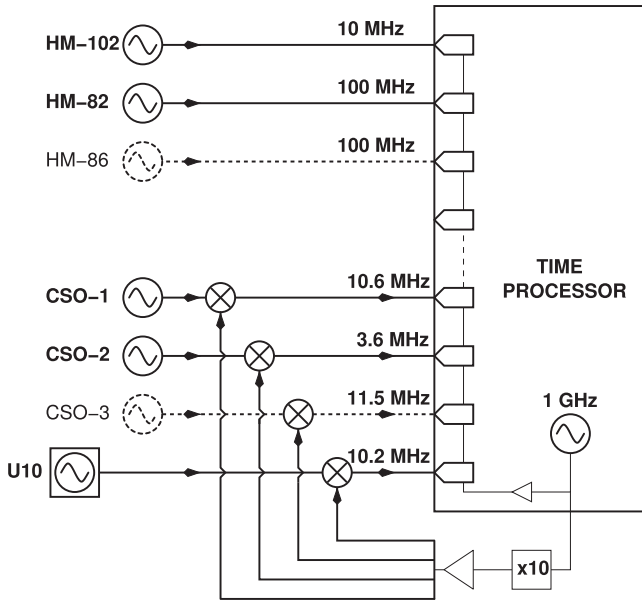

FIG. 2. Measurement setup. U10 was compared to the cryogenic sapphire oscillators CSO-1 and CSO-2 and the hydrogen masers HM-102 and HM-82. The two others reference sources, i.e., CSO-3 and HM-86, were used for health check.

generation CSOs, placed in two independent temperature stabilized room at $22 \pm 0.5^\circ\text{C}$.²⁶ The first inputs of the Time Processor receive the hydrogen maser signals at 10 or 100 MHz and compare them with the 1 GHz local oscillator of the instrument. The latter is compared also with U10 and with the three reference CSOs by means of a by-10 frequency multiplier and of frequency mixers that produce three beatnotes in the 10 MHz range. The instrument measures the three beatnotes and scales the results to the nominal frequencies of the CSOs. In this way, the residual noise of the instrument is reduced by about three orders of magnitude and becomes completely negligible. In the second step, the phase-time difference of U10 with respect to the other channels is computed and used to calculate the two-sample covariance of U10 with respect to two CSOs and two HMs. We point out that these differences cancel out the contribution of the local oscillator that, thus, does not contribute to the measure. The results presented here have been obtained using CSO-1, CSO-2, IM-102, and IM-82 as references. The permutations done with CSO-3 and IM-86 led to the same results, demonstrating the reproducibility of the procedure.

U10 was turned on for the first time in March 2022. Then, during the first month, the parameters of the different control loops were adjusted and optimized. During this phase, the CSO experienced significant variations in its operating parameters. Thereafter, the CSO was left running, and the first stability assessment began. The following evaluations were carried out just after this adjustment phase, and the CSO still had a significant drift, i.e., $6 \times 10^{-14}/\text{day}$ that slowly decreases over time. Thereby, for all the results presented here, the ADEV calculations have been computed after a drift removal. The reasons for such frequency drifts are still being investigated. However, we have ruled out any technical issues including aging of electronic components and thermal sensors. The most accredited hypothesis is that drift results from the relaxation of mechanical stress in the sapphire

crystal.^{27,28} It can, thus, vary from a resonator to another depending on its clamping force and on the crystal history and, in particular, to the annealing process carried out by the manufacturer. We note that the oldest CSOs we implemented have the lowest frequency drift.^{20,29} This fact supports a correlation between drift and crystal growth method, where HEM growth of the oldest crystals results in a lower drift. However, data are insufficient to draw a clear conclusion.

At short term, the three reference CSOs are far better than the hydrogen masers. They reach an ADEV better than 1×10^{-15} for $\tau = 1$ s, while it is typically 7×10^{-14} for the HMs. Thanks to correlation and averaging that are inherent to two-sample covariance, the influence of the reference sources frequency fluctuations on the measured ADEV is reduced by $m^{1/4}$, m being the number of measurements at a given integration time τ . The two CSOs are used for the evaluation of the short term, since their frequency noise is much lower than masers, and, thanks to the number of averages, their contribution is below 1×10^{-16} . Such level of resolution could not be reached by using the two HMs, since it would require an unrealistic acquisition time.

For $\tau \geq 700$ s, the CSOs' frequency fluctuations are partially correlated owing to pulling by the common fluctuating temperature of the room in where the CSOs are located. The covariance method applied in this integration time range gives for U10 a negative and unrealistic ADEV. Such a level of correlation does not exist between the HMs frequency fluctuations because (i) the HM thermal sensitivity is about ten times lower than that of CSOs, (ii) the heat generated by the instruments is lower in the HM room, and (iii) the situation in the building is more favorable for the HM room, making the ambient temperature regulation more easy to tune.

Thus, Fig. 3 represents the U10 ADEV, obtained by combining the calculations made with two different sets of data. Until $\tau = 700$ s, the U10 ADEV is determined from the comparison with CSO-1 and CSO-2, and for the longer integration times, the comparison with HM-102 and HM-82 is used.

The most important result is that the relative frequency instability of U10 is less than 2×10^{-16} for $100 \text{ s} \leq \tau \leq 10\,000 \text{ s}$, making the CSO the best commercially available oscillator based on a macroscopic resonator. At longer integration time, the U10 ADEV appears limited by a random walk process, such as $\sigma_y(\tau) \sim 1.1 \times 10^{-18} \sqrt{\tau}$.

Some deviations of the actual ADEV from these two asymptotes can be explained. At short term, the hump #1 around few seconds

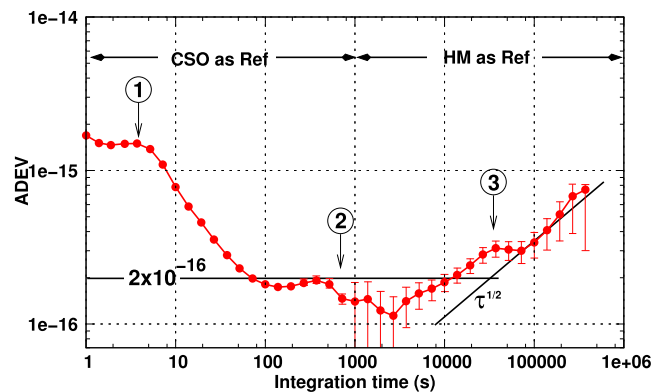

FIG. 3. U10 ADEV mean estimates. Error bars: 68% confidence intervals.

results from the imperfect resonator temperature stabilization as demonstrated in.^{16,24} Then, the resonator and its surroundings thermal mass filter the residual temperature fluctuations, and the ADEV rolls off with a slope $\sim\tau^{-1}$ until about 100 s. Note that better short-term frequency stability has been obtained with resonator characterized by $T_0 < 6$ K.^{16,22} The notch #2, which appears just before 1000 s, is the residual of the unrealistic ADEV roll-off due to the correlation existing in the CSO references frequency fluctuations. Eventually, at around half a day, the small bump, i.e., #3 in Fig. 3, can be the signature of the daily temperature fluctuations revealed by the U10 residual sensitivity.

The reason why U10 is more stable than the previous CSOs in the medium term are still unclear. That said, we discuss conjectures and avenues of future research.

This is the first systematic use of the Time Processor for the characterization of a CSO, while the previous CSOs were validated using the classical TCH method. Comparing the experiments, we suspect that the previous frequency stability measurement was somewhat corrupted in the mid-term region by hidden correlated phenomena.

Notwithstanding the same design, there are small differences between samples of ULISS-2G, hard to control accurately. This is the case of (i) the clamping force on the resonator's spindle, (ii) the thermal resistance in the contact between the different subsystems, and (iii) the coupling of the main resonance to nearby spurious modes. Likewise, ferromagnetic components at a low temperature (isolators and circulators close to the resonator) suffer from a spread of isolation, S parameters, and phase noise.

The overall environmental sensitivity of the oscillator is affected in a small but unpredictable way by these uncontrolled experimental parameters. In some circumstances, the interplay between parts may result in a partial compensation of the temperature fluctuations.

Finally, the remarkable frequency stability achieved by U10 validates the CSO technology. Our measurements set an upper limit to the noise of the resonator's frequency flicker at $\sigma_y = 2 \times 10^{-16}$ (Allan variance). This value may be used to test physical theories about the ultimate stability of crystals, as it has been done with optical Fabry-Pérot cavities.

This work was partially supported by (i) ANR, FIRST-TF Network (Grant No. ANR-10-LABX-48-01), (ii) ANR Oscillator IMP Project (Grant No. ANR11-EQPX-0033-OSC-IMP), (iii) ANR EUR EIPHI Graduate School (Grant No. ANR-17-EURE-00002), and (iv) grants from the Région Bourgogne Franche Comté intended to support the above-mentioned projects.

AUTHOR DECLARATIONS

Conflict of Interest

The authors have no conflicts to disclose.

Author Contributions

Christophe Fluhr: Investigation (equal); Validation (equal); Writing – original draft (equal); Writing – review & editing (equal). **Benoit Dubois:** Investigation (supporting); Software (equal); Writing – original draft (supporting); Writing – review & editing (supporting). **Claudio Eligio Calosso:** Formal analysis (equal); Methodology (equal); Software (lead); Writing – original draft (supporting); Writing – review & editing (supporting). **François Vernotte:** Formal analysis

(equal); Investigation (equal); Writing – original draft (supporting). **Enrico Rubiola:** Formal analysis (equal); Investigation (equal); Writing – original draft (supporting); Writing – review & editing (supporting). **Vincent Giordano:** Formal analysis (equal); Investigation (equal); Writing – original draft (lead); Writing – review & editing (lead).

DATA AVAILABILITY

The data that support the findings of this study are available from the corresponding author upon reasonable request.

REFERENCES

- ¹P. Wolf, S. Bize, A. Clairon *et al.*, “Test of Lorentz invariance using a microwave resonator,” *Phys. Rev. Lett.* **90**, 060402 (2003).
- ²C. Eisele, A. Y. Nevsky, and S. Schiller, “Laboratory test of the isotropy of light propagation at the 10^{-17} level,” *Phys. Rev. Lett.* **103**(9), 090401 (2009).
- ³M. Takamoto, I. Ushijima, N. Ohmae *et al.*, “Test of general relativity by a pair of transportable optical lattice clocks,” *Nat. Photonics* **14**(7), 411–415 (2020).
- ⁴W. M. Campbell, B. T. McAllister, M. Goryachev *et al.*, “Searching for scalar dark matter via coupling to fundamental constants with photonic, atomic, and mechanical oscillators,” *Phys. Rev. Lett.* **126**(7), 071301 (2021).
- ⁵M. Rioja, R. Dodson, Y. Asaki *et al.*, “The impact of frequency standards on coherence in VLBI at the highest frequencies,” *Astronomical J.* **144**(4), 121 (2012).
- ⁶B. Alachkar, A. Wilkinson, and K. Grainge, “Frequency reference stability and coherence loss in radio astronomy interferometers application to the SKA,” *J. Astronomical Instrum.* **07**(01), 1850001 (2018).
- ⁷V. Dolgovskiy, S. Schilt, N. Bucalovic *et al.*, “Ultra-stable microwave generation with a diode-pumped solid-state laser in the 1.5- μ m range,” *Appl. Phys. B* **116**(3), 593–601 (2014).
- ⁸J. W. Zobel, M. Giunta, A. J. Goers *et al.*, “Comparison of optical frequency comb and sapphire loaded cavity microwave oscillators,” *IEEE Photonics Technol. Lett.* **31**(16), 1323–1326 (2019).
- ⁹G. Santarelli, C. Audoin, A. Makdissi *et al.*, “Frequency stability degradation of an oscillator slaved to a periodically interrogated atomic resonator,” *IEEE Trans. Ultrason., Ferroelectr., Freq. Control* **45**(4), 887–894 (1998).
- ¹⁰M. Abgrall, J. Guéna, M. Lours *et al.*, “High-stability comparison of atomic fountains using two different cryogenic oscillators,” *IEEE Trans. Ultrason., Ferroelectr., Freq. Control* **63**(8), 1198–1203 (2016).
- ¹¹J. M. Robinson, E. Oelker, W. R. Milner *et al.*, “Crystalline optical cavity at 4 K with thermal-noise-limited instability and ultralow drift,” *Optica* **6**(2), 240–243 (2019).
- ¹²W. H. Horton and G. E. Hague, “Dynamic measurement of amplitude-frequency effect of VHF resonators,” *IEEE Trans. Ultrason., Ferroelectr., Freq. Control* **53**(1), 159–166 (2006).
- ¹³S. Chang, A. G. Mann, A. N. Luiten *et al.*, “Measurements of radiation pressure effect in cryogenic sapphire dielectric resonators,” *Phys. Rev. Lett.* **79**, 2141–2144 (1997).
- ¹⁴V. Giordano, S. Grop, P.-Y. Bourgeois *et al.*, “Influence of the electron spin resonance saturation on the power sensitivity of cryogenic sapphire resonators,” *J. Appl. Phys.* **116**(5), 054901 (2014).
- ¹⁵F. Vernotte, C. E. Calosso, and E. Rubiola, “Three-cornered hat versus Allan covariance,” in *Proceedings of 2016 IEEE International Frequency Control Symposium (IFCS)* (IEEE, 2016), pp. 1–6.
- ¹⁶C. Fluhr, S. Grop, B. Dubois *et al.*, “Characterization of the individual short-term frequency stability of cryogenic sapphire oscillators at the 10^{-16} level,” *IEEE Trans. Ultrason., Ferroelectr., Freq. Control* **63**(6), 915–921 (2016).
- ¹⁷C. E. Calosso, F. Vernotte, V. Giordano *et al.*, “Frequency stability measurement of cryogenic sapphire oscillators with a multichannel tracking DDS and the two-sample covariance,” *IEEE Trans. Ultrason., Ferroelectr., Freq. Control* **66**(3), 616–623 (2019).
- ¹⁸E. Oelker, R. Hutson, C. Kennedy *et al.*, “Demonstration of 4.8×10^{-17} stability at 1 s for two independent optical clocks,” *Nat. Photonics* **13**(10), 714–719 (2019).

- ¹⁹V. Giordano, S. Grop, B. Dubois *et al.*, “New generation of cryogenic sapphire microwave oscillator for space, metrology and scientific applications,” *Rev. Sci. Instrum.* **83**, 085113 (2012).
- ²⁰V. Giordano, S. Grop, C. Fluhr *et al.*, “The autonomous cryocooled sapphire oscillator: A reference for frequency stability and phase noise measurements,” *J. Phys.: Conf. Ser.* **723**(1), 012030 (2016).
- ²¹See <http://www.uliss-st.fr/> for information about the CSO ULISS-2G.
- ²²C. Fluhr, B. Dubois, S. Grop *et al.*, “A low power cryocooled autonomous ultra-stable oscillator,” *Cryogenics* **80**, 164–173 (2016).
- ²³C. Fluhr, B. Dubois, G. Le Tetu *et al.*, “ULISS-2G ultra stable cryocooled microwave sapphire oscillator: A mature and reproducible technology,” in *2022 3rd URSI Atlantic and Asia Pacific Radio Science Meeting (at-AP-RASC)* (IEEE, 2022), pp. 1–3.
- ²⁴C. Fluhr, B. Dubois, G. Le Tetu *et al.*, “Reliability and reproducibility of the cryogenic sapphire oscillator technology,” *IEEE Trans. Instrum. Meas.* **72**, 1 (2023).
- ²⁵C. E. Calosso, “Tracking DDS in time and frequency metrology,” in *2013 Joint European Frequency and Time Forum & International Frequency Control Symposium (EFTF/IFC)* (IEEE, 2013), pp. 747–749.
- ²⁶See <https://www.femto-engineering.fr/en/equipement/oscillator-instability-measurement-platform/> for information about the metrological platform Oscillator-IMP.
- ²⁷S. Chang and A. G. Mann, “Mechanical stress caused frequency drift in cryogenic sapphire resonators,” in *Proceedings of the 2001 IEEE International Frequency Control Symposium and PDA Exhibition*, Seattle, WA, USA (IEEE, 2001), pp. 710–714.
- ²⁸M. E. Tobar, E. N. Ivanov, C. R. Locke *et al.*, “Long-term operation and performance of cryogenic sapphire oscillators,” *IEEE Trans. Ultrason., Ferroelectr., Freq. Control* **53**(12), 2386–2393 (2006).
- ²⁹S. Grop, W. Schäfer, P.-Y. Bourgeois *et al.*, “Unprecedented long-term frequency stability with a microwave resonator oscillator,” *IEEE Trans. Ultrason., Ferroelectr., Freq. Control* **58**(8), 1694–1697 (2011).