



ISTITUTO NAZIONALE DI RICERCA METROLOGICA Repository Istituzionale

Recent advancements and perspectives of INRiM's time-dependent Josephson voltage standards

Original

Recent advancements and perspectives of INRiM's time-dependent Josephson voltage standards / Durandetto, Paolo; Serazio, Danilo; Sosso, Andrea. - In: ACTA IMEKO. - ISSN 2221-870X. - 12:3(2023), pp. 1-6. [10.21014/actaimeko.v12i3.1436]

Availability:

This version is available at: 11696/78159 since: 2023-11-10T10:38:35Z

Publisher:

IMEKO

Published

DOI:10.21014/actaimeko.v12i3.1436

Terms of use:

This article is made available under terms and conditions as specified in the corresponding bibliographic description in the repository

Publisher copyright

(Article begins on next page)

Recent advancements and perspectives of INRiM's time-dependent Josephson voltage standards

Paolo Durandetto¹, Danilo Serazio¹, Andrea Sosso¹

¹ INRiM - Istituto Nazionale di Ricerca Metrologica, Strada delle Cacce 91, Turin, Italy

ABSTRACT

Quantum voltage standards based on ac Josephson effect have been used in metrology since a few years after the discovery of the physical phenomenon. The role of quantum standards is now crucial following the SI redefinition in 2019: electrical units are today defined in terms of the fundamental constants e (elementary charge) and h (Planck's constant). The extremely low uncertainty in dc measurements, that can be lower than 1 nV/V at 10 V, is stimulating research to extend application to ac and signals arbitrarily changing with time. Approaching the dc accuracy is challenging, however. The two main technologies used for the generation of non-steady voltage signals are programmable and pulsed Josephson junction arrays. In this work we discuss the main advancements obtained at the Italian Istituto Nazionale di Ricerca Metrologica (INRiM) with both technologies, and the most recent developments taking advantage of He-free device cooling techniques.

Section: RESEARCH PAPER

Keywords: Josephson standards; voltage; cryocooler; quantum metrology; ac voltage

Citation: Paolo Durandetto, Danilo Serazio, Andrea Sosso, Recent advancements and perspectives of INRiM's time-dependent Josephson voltage standards, Acta IMEKO, vol. 12, no. 3, article 19, September 2023, identifier: IMEKO-ACTA-12 (2023)-03-19

Section Editors: Jan Saliga, Technical university of Kosice, Slovakia, Jakub Svatos, CVUT Prague, Czech Republic, Platon Sovilj, University of Novi Sad, Serbia

Received December 21, 2022; **In final form** July 20, 2023; **Published** September 2023

Copyright: This is an open-access article distributed under the terms of the Creative Commons Attribution 3.0 License, which permits unrestricted use, distribution, and reproduction in any medium, provided the original author and source are credited.

Corresponding author: Paolo Durandetto, e-mail: p.durandetto@inrim.it

1. INTRODUCTION

Josephson array voltage standards represent one of the most relevant achievements in superconducting integrated electronics and are fabricated only in few laboratories worldwide. Their significance has grown exponentially, particularly in light of the 2019 SI redefinition [1], where electrical units are now defined in terms of the fundamental constants. Dc Josephson arrays with tunnel junctions operated at 4.2 K can generate steady voltages up to 10 V with relative uncertainties better than 10^{-9} [2], [3], but rapidly setting a voltage value and generating waveforms with quantum accuracy is very difficult. Josephson junctions in dc voltage standard applications are based on highly hysteretic Superconductor-Insulator-Superconductor (SIS) junctions with zero-crossing steps, i.e., overlapping voltage steps with current range that spans positive and negative values, hence including the condition of zero dc bias. The current-voltage (I - V) relationship is then not one-to-one [4] and it is not possible to control the voltage through electrical bias.

This is otherwise possible in Programmable Josephson Voltage Standards (PJVS). Their I - V curve under microwave irradiation is a staircase function, thus the output voltage is

univocally defined by the current sent through the bias circuit. Such arrays are generally subdivided in sub-circuits with series-connected junctions generating voltages following a power-of-two rule: combining the voltage across all sections it is thus possible to source binary programmed voltages equivalent to the technique used in electronic digital-to-analog converters. This rapid and easy programmability of novel Josephson voltage standards is exploited also outside the electrical metrology field, e.g. in Kibble balances [5] for the quantum traceability of the kg unit to the SI through h e e , in conjunction with the quantum Hall resistance standards.

Many approaches to junction fabrication have been developed, and several different technologies have proven successful in generating voltages up to 10 V, with good metrological properties: SINIS [6], SNIS [7], [8] with respectively Nb, Al and AlO_x as superconducting (S), normal (N) and insulating (I) elements, the more recent SNS junctions with $\text{Nb}_x\text{Si}_{1-x}$ barriers [9], and NbN/TiN_x/NbN junctions for higher temperature operation [10]. The most relevant limitation of PJVS devices is to be found in the time for step switching, when junctions are not operating in a quantized state. During these transients, the array voltage is not accurately known, thus

programmable arrays can match primary metrology uncertainties requirements only for signals up to few hundreds Hz.

To get rid of the limitations of programmable standards, arrays operating with a pulsed, square wave, radiofrequency signal have been developed. Making use of short pulses in place of a continuous sinusoidal wave it is possible to suitably modulate the signal period spanning a wide range of frequencies. Fundamental accuracy follows from the control of the flux quanta associated to a single pulse going through a junction. It follows that the output voltage of the array is exactly calculable in terms of fundamental constants if the number of the quanta per unit time, i.e. the pulse repetition rate, is known. The output voltage is then derived from fundamental constants from:

$$V_n = \Phi_0 N n f_{\text{rep}}, \quad (1)$$

where $\Phi_0 = h/(2e) \approx 2.07$ fWb is the magnetic flux quantum, N is the number of junctions in the array and n is the Shapiro step number, i.e. the number of flux quanta transferred for each current pulse. N and n being fixed, the voltage depends only on the instantaneous pulse repetition frequency f_{rep} , which typically lies in the radiofrequency (rf) region, up to 15 GHz. From the point of view of eq. (1), PJVS arrays differ from pulsed standards in that N is varied to change the quantized output voltage.

Since the determination of the repetition rate is basically a frequency measurement, this can be done with extreme accuracy and the Josephson effect brings the accuracy of time and frequency measurements into voltage calibrations [11]. Pulsed standards can synthesize arbitrary waveforms with quantum accuracy, taking advantage of the $\Sigma\Delta$ technique for digital-to-analog conversion developed for semiconductor electronics, providing very high spectral purity. However, both operation and fabrication of pulsed standards set very challenging problems, in particular the most relevant limitation of pulsed standard is to be found in the smaller amplitudes attainable compared to PJVS, together with the complexity of the apparatus.

In this paper, which extends the research presented in [12], we discuss the main breakthroughs achieved at INRiM utilizing both JVS technologies, along with the latest innovations benefiting from He-free device cooling methods.

2. QUANTUM STANDARDS FOR AUDIOFREQUENCIES

New generation ac quantum voltage standards are based on Josephson junctions where dissipative effect dominates, namely the junction capacitance can be neglected. These show a non-hysteretic behaviour in the IV curve that allows changing the output voltage through the control of the bias current. In other words, the IV curve under irradiation is a one-to-one staircase (see for instance Figure 1), thus the output voltage is univocally defined by the current fed through the controlling circuit. This is totally different from the case of hysteretic junctions used in conventional dc standards, where steps are overlapping and all share approximately the same interval of currents. The one-to-one relation property of more recent Josephson junctions is exploited in the so-called programmable standards, where the junctions bias currents are used to activate/deactivate array sections.

Programmable arrays are subdivided in sections with series-connected junctions generating voltages following a power of two sequence. Combining the sections, it is then possible to source binary programmed voltages in a way that is very similar to the technique used in electronic digital to analog converters

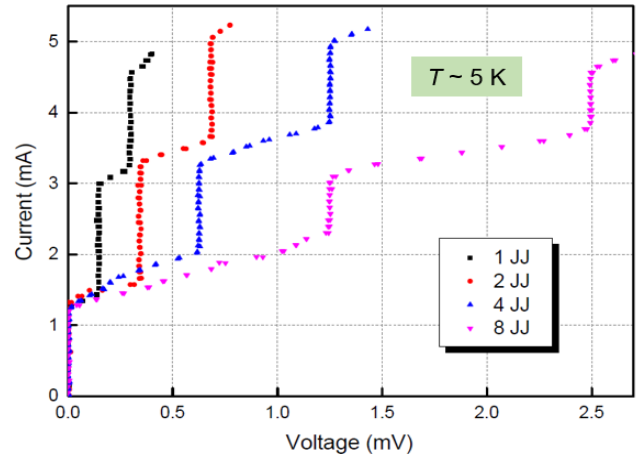

Figure 1. IV characteristics of the smallest segments of a 1 V SNIS PJVS standard operated in cryocooler at 5 K and radiated at about 70 GHz.

[13]. Programmable Josephson arrays are, so far, the most effective result extending metrological applications of Josephson standards beyond dc (in the audiofrequency range, up to 2 kHz), and have been used for several applications and provide output voltages exceeding 10 V [14]. To date, turnkey ac quantum voltmeters based on a 10 V PJVS array are commercialized by Supracon AG (Germany) and National Institute of Standards and Technologies (NIST – USA) in both LHe and cryocooler versions, allowing the automated calibrations of ac voltmeters and ac voltage sources up to 10 V and frequencies up to the kHz range. Moreover, recent advancements are underway to use PJVSs in sub-sampling mode to measure signals above 1 kHz [15].

In programmable standards, a crucial role is played by the measurement program that controls the bias of array sections, undertakes first data processing (e.g., step verification), and evaluates data validity. The high complexity of quantum-based devices places software in a fundamental role. We developed at INRiM a Python package for automated measurements with a modular and expandable structure [16] suited to different calibration and testing purposes. Differently from the existing software, as the closed-source software distributed within commercial systems, the open-source approach adopted offers a well-known and tested framework for these needs, based on a collaborative effort and improved by shared information and the updates contributed by the community.

INRiM started developing a custom technology for fabrication several years ago. Low-hysteresis (overdamped) junctions developed at INRiM can be derived from hysteretic Nb/Al-AIO_x/Nb SIS junctions technology, but the thickness of the Al layer is significantly higher. These junctions can be described as SNIS, since the thick aluminum film is a normal metal at liquid helium (LHe) temperature. An essential feature is that, at 4.2 K, a transition from the hysteretic to the non-hysteretic state can be induced by changing AIO_x exposure. Another interesting feature of SNIS junctions for metrological applications and quantum computing is the high value of current densities achievable and, consequently, of characteristic voltage. This makes SNIS junctions potentially advantageous with respect to other technologies, facilitating the operation of PJVS arrays above 4.2 K in compact cryocoolers, in the view of the future substitution of expensive and complex LHe refrigeration systems and the consequent diffusion of voltage standards to the private companies. Indeed, present Josephson junction technologies

with high temperature superconductors, like YBCO or MgB₂, are not yet proven effective in providing the integration levels required for large array fabrication [17]. On the other side, the use of SNIS junctions at temperatures close to 4.2 K is favourable for the generation of wide high order steps, again thanks to the large characteristic voltages [18]. In the framework of a fruitful cooperation between INRiM and PTB, PJVS devices made with SNIS junctions and with output voltage of 1 V have been fabricated and successfully operated at microwave frequencies around 70 GHz [19].

Subsequently, we deeply investigated the development of programmable standards operating at step orders above the first one, making it possible to synthesize stepwise quantum voltage waveforms with fewer bias lines and fewer Josephson junctions, without losses in terms of performances [20]. In particular, we proposed to simultaneously exploit zero, first and second Shapiro steps to reduce junctions and bias lines by a factor of two. Suitable quantum steps up to the second are easily obtained for the smallest PJVS segments, as shown in [20]. More stringent requirements in terms of rf frequency, power distribution and junctions uniformity of electrical parameters are instead needed for simultaneous operation of largest segments as well. A further extension to steps $n = 0, \pm 1, \pm 2$ allows to encode a generic voltage value more effectively with respect to the conventional binary coding.

3. PULSED STANDARDS TOWARD RF

Pulse-driven Josephson junctions arrays have proven successful in generating ac voltage waveforms with very pure frequency spectra. They are the basis for the Josephson Arbitrary Waveform Synthesizer (JAWS). Compared to PJVS, JAWS is capable of synthesizing waveforms at much higher frequencies (up to the MHz range) and with rms output voltages up to 4 V [21].

In JAWS principle of operation is based on the irradiation of arrays with a train of sub-nanosecond pulses with rise-time of few tens of picoseconds: fundamental accuracy follows from the control of the flux quanta transferred through the junctions in each pulse. It is possible then to synthesize arbitrary waveforms with quantum accuracy by continuously varying this repetition frequency, which is generally in the range of microwaves (up to about 15 GHz in existing JAWS setups). The waveform to be synthesized is encoded into a 0/1 or 1/0/-1 bitstream by means of $\Sigma\Delta$ modulation techniques. In our setup, schematically represented in Figure 2, the $\Sigma\Delta$ code is generated with a program written in Python and then loaded into the circulating memory of two pulse generators, one for positive and one for negative pulses, properly phased and synchronized. Then, each junction in the array quantizes the area within each delivered current pulse to multiples of the flux quantum Φ_0 . A compensation current signal I_{comp} is often required when dc-blocking capacitors are used to make the Josephson array floating from electrical ground and to avoid common-mode voltage errors across the termination resistor R_{load} , hence by implementing the so-called ac-coupling technique [22]. Finally, several parameters (pulse amplitudes, compensation current amplitude and phase, also temperature sometimes) have to be properly adjusted to obtain the programmed quantum-defined voltage signal, after being suitably filtered by on-chip inductive low-pass filters (LPF).

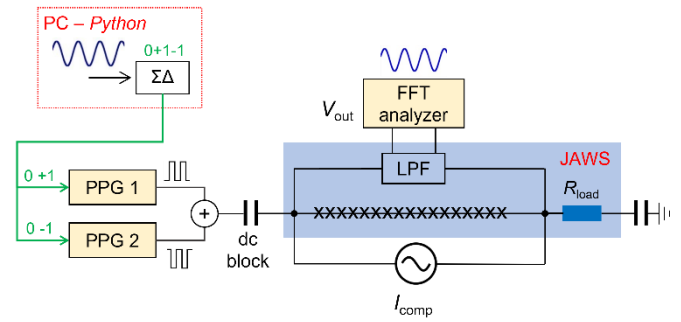

Figure 2. Schematic representation of JAWS ac voltage synthesis and experimental setup.

4. CRYOCOOLER OPERATION

The extremely low temperatures required for the operation of superconducting devices is generally regarded as the major limitation to a widespread usage. To cool down ordinary superconductors at 4.2 K the standard technique is based on LHe refrigeration, where all the experiment is immersed, isothermally, in a helium bath. On the other side, more recent He-free systems are interesting because of ease of use, the savings over high costs of LHe, the absence of risk of shortages [23], and the negligible concerns for operators safety. Yet, proper cryocooler operation necessitates a very specific thermal design to face with problems that are not of concern with liquid coolants, e.g., minimization of thermal gradients to allow uniform operation of the chip. Moreover, the He-free refrigerator has reduced cooling power, thus the rf signal transmission to the chip must be carefully designed in order to limit the heat load on the low temperature stage of the cooler without compromising signal transmission. Additionally, cryocooled standards are particularly interesting for pulsed standard applications, where frequency dependent unwanted effects in the synthesized waveforms are due to the loading of voltage leads. It is possible to reduce these errors by using shorter cables, but this condition cannot be fully realized in LHe systems, where cables are more than 1-m long, while they can be more than halved in a mechanical cooler. Nowadays, turnkey JAWS systems with voltage up to 2 V are commercially available only at NIST, with a price of about 400 k€ for the most complete cryocooled version.

In the last decade, we set up two flexible cryogen-free refrigeration systems suited for operation of both programmable and pulsed Josephson voltage standards. These are built on two-stage cryocoolers with 1 W cooling power at 4 K and minimum temperature below 3 K (without thermal loads). The second stage of the coolers is fitted with an additional disk (the coldplate, henceforth) made of high thermal conductivity oxygen-free copper. In both systems, the coldplate hosts a thermometer and a heater to finely monitor and control its temperature. A second thermometer is free to be installed wherever necessary, e.g. onto the carrier, in proximity of the Josephson chip. Either a stainless-steel WR-12 waveguide, for the 70 GHz rf transmission required for PJVS arrays, or a low thermal conductivity coaxial cable made of beryllium-copper, for JAWS pulsed bias up to 30 GHz bandwidth, can be installed to reduce the thermal link between the cold region and the outer stages of the cryocooler and the laboratory environment.

The apparatuses can be easily switched between the two available ac Josephson voltage standards (Figure 3).

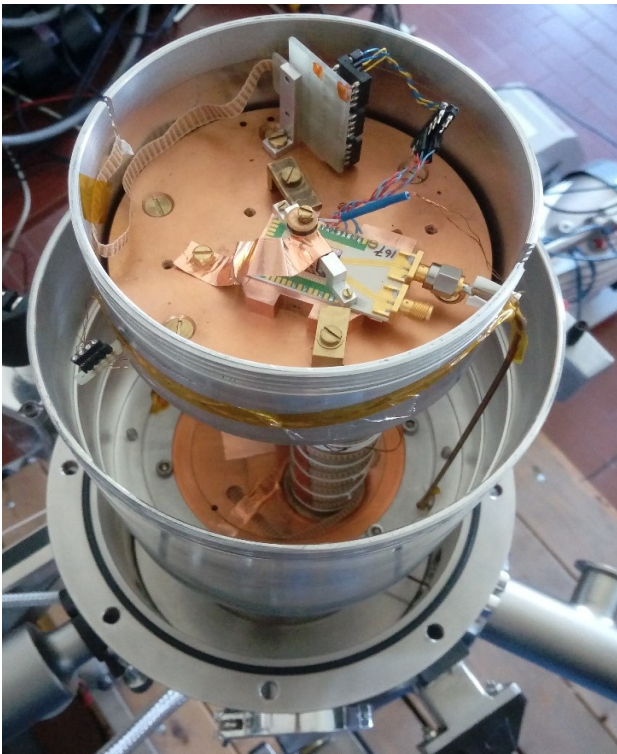

Figure 3. JAWS standard installed on the coldplate of a two-stage pulse-tube cryocooler.

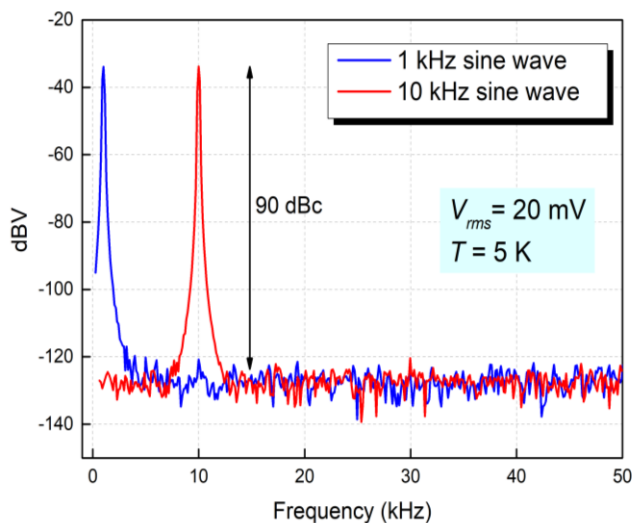

Figure 4. FFT spectra of sinusoidal waveforms synthesized with a JAWS array with 4000 SNS junctions in cryocooler.

As described previously, junctions fabricated with SNIS technology lend themselves as a good option for operation at temperatures above 4.2 K. In particular they show some specific properties with regard to temperature stability of its electrical parameters, measured as the temperature derivative of I_c and V_c vs. temperature [24]-[30]. SNIS arrays are interesting candidates for a cryocooled standard, providing a compromise between device and refrigerator requirements. We tested several SNIS arrays in cryocooler to study properties at different temperatures and determine optimal operating conditions. Voltage steps exceeding 1 V were observed well above 4.2 K with a binary-divided PJVS of 8192 junctions, confirming results observed in evaporating He gas within a LHe dewar.

With pulsed standards, the setup was tested for the synthesis of pure sine waves (Figure 4) as well as for the study of the cable-loading effect. It is widely recognized that, approaching the MHz range, the most relevant uncertainty contribution in JAWS standards is due to frequency-dependent errors originated by the loading effect of voltage leads [31], [32]. One way to reduce these errors is to use shorter cables, though this condition cannot be fully realized in LHe systems, where cables are more than 1-m long. Using compact cryocooler, the cable length can be at least halved. We developed and tested thoroughly a cryogen-free refrigeration system capable of operating a pulsed standard where cable length is halved with respect to LHe setups [33]. Ultimately, this effect is due to the limitations in the currents sourced by the array to the circuit. Since the maximum current is set by the array quantum margins, a few mA at best, the possibility of operating such a standard with a 50Ω matched line is ruled out. Any instrument connected to a pulsed standard must then be set for high impedance operation and interconnecting cables are then seen as lumped capacitive loads by the Josephson device. At higher frequencies (~ 100 kHz), the connection between pulsed array and voltmeter must be regarded as a transmission line with open end, which significantly alters the quantum-accurate signal generated in the 4 K environment. Among the several attempts to reduce and mitigate this unwanted effect one can mention the minimization of the waves reflected by the load [31] and a measurement bridge that compensates for the cable parasitics in the measurement [34]. Since these techniques have intrinsic limitations, a shortened cryoprobe was recently proposed as a way to straightforwardly mitigate the problem. It is known that these effects depend on cable length following a square law, thus shorter cables, even by a small amount, can dramatically reduce them. Our cryocooled system significantly reduces the length of the connection between the colder stage where the pulsed array is installed and the room temperature output port. First experiments with a calibrated thermal converter showed larger deviations than expected which should be investigated [35].

Proper operation of a Josephson standard in cryocooler is always a challenging task, owing to the tight thermalization requirements [36]-[38] alongside the need of supplying non negligible dc and rf power for proper operation (up to 150 mW). We addressed this issue by designing an optimized cryopackage to maximize the thermal contact between the chip and the cooling surface [39]. It takes advantage of a soft indium foil with a corrugate surface for optimal transmission, achieved by filling the voids between rough surfaces. This approach avoids soldering the parts, a solution that is prone to cracks and surface damage with thermal cycling. Moreover, a highly conductive, electrical insulating, sapphire lamina is placed on the top of the chip, thus further contributing to the total heat conduction. Thorough tests of thermal conduction, using some junctions as temperature sensors, showed better performance than different methods reported in literature. A specially designed structure guarantees the reproducibility of results and strict control of mechanical parameter.

More recent studies have shown that thermal issues in cryocooler operation of quantum standards can be tackled directly by a refined control of the average temperature of the chip [40]: the latter can be monitored and stabilized using Josephson junctions as thermal sensor, thanks to the strong dependence of electrical parameters with temperature in the superconducting state. Also, on-chip active compensation of temperature fluctuations, caused by the cooling cycle exploited

by the cryocooler, is underway to cancel the annoying effect of Josephson junction $I\!V$ curves “breathing” in phase with the cryocooler motion, causing the current-amplitude of quantum voltage steps to be largely reduced and, in the worst case, completely unusable. This would represent a valuable alternative to (or work in conjunction with either) passive damping techniques, especially on damper-free cryocoolers that cannot be retrofitted with an additional thermal mass.

5. CONCLUSIONS

In the future, programmable and pulse-driven Josephson voltage standards will fully replace conventional “only-dc” JVS as well as ac voltage calibration techniques based on classical effects [41] and, therefore, not directly linked to the brand new quantum SI units. To meet this goal, several aspects have still to be optimized, in order to extend both voltage and frequency ranges of the two time-dependent Josephson standards, to simplify their operation and to improve calibration accuracy in the specific ranges and applications where conventional methods still dominate. In addition, the spread of quantum voltage standards, and of superconducting electronics in general, outside National Metrology Institutes, research institutions and universities will be favoured more and more by the availability and increasing completeness of turnkey measurement systems based on cryocoolers.

As summarized in this paper, INRiM has been working for years to achieve these objectives along with several research groups worldwide. PJVS based systems have been implemented and are about to be exploited for both dc and low-frequency ac measurements. Accurate ac voltage measurement tools above the kHz-range are also under development with JAWS standards. Besides the ease of use, the use of cryocoolers is fundamental for the research and the development of such novel JVS-based systems, owing to the high cost and complexity of LHe and its short duration. Instead, a cryocooler can, in principle, work uninterruptedly wherever a power outlet is available. Related thermal issues (heat dissipation and temperature stability) are mostly solved, thus reducing more and more the few advantages of LHe cooling.

ACKNOWLEDGEMENT

The authors are grateful to Oliver Kieler (PTB, Germany) for providing the JAWS arrays and for his unvaluable assistance, to Natascia De Leo and Matteo Fretto (INRiM) for providing the SNIS PJVS arrays, to Eugenio Monticone (INRiM), and to Fulvio Francone (INRiM) for designing and manufacturing part of the experimental setup.

REFERENCES

- [1] M. Stock, R. Davis, E. de Mirandés, M. J. Milton, The revision of the SI – the result of three decades of progress in metrology, *Metrologia* 56(2) (2019), art. No. 022001. DOI: [10.1088/1681-7575/ab0013](https://doi.org/10.1088/1681-7575/ab0013)
- [2] R. Behr, A. S. Katkov, Final report on the key comparison EUROMET. BIPM. EM-K10. a: Comparison of Josephson array voltage standards by using a portable Josephson transfer standard, *Metrologia* 42(1A) (2005), art. No. 01005. DOI: [10.1088/0026-1394/42/1A/01005](https://doi.org/10.1088/0026-1394/42/1A/01005)
- [3] F. Müller, T. J. Scheller, J. Lee, R. Behr, L. Palafox, M. Schubert, J. Kohlmann, Microwave design and performance of PTB 10 V circuits for the programmable Josephson voltage standard, *World Journal of Condensed Matter Physics* 4(3) (2014), art. No. 107. DOI: [10.4236/wjcmp.2014.43016](https://doi.org/10.4236/wjcmp.2014.43016)
- [4] V. Lacquaniti, A. Sosso, Josephson junctions for present and next generation voltage metrology, *Modern Metrology Concerns*. InTech, ISBN 978-953-51-0584-8, (2012), pp. 117-142. DOI: [10.5772/36429](https://doi.org/10.5772/36429)
- [5] N. Rogge, C. Rothleitner, S. Lin, S. Vasilyan, T. Fröhlich, F. Härtig, D. Knopf, Error sources in the force mode of the “PB2” Planck-Balance, *Acta IMEKO* 9(5) (2020), pp. 53-57. DOI: [10.21014/acta_imeko.v9i5.938](https://doi.org/10.21014/acta_imeko.v9i5.938)
- [6] H. Schulze, F. Müller, R. Behr, J. Kohlmann, J. Niemeyer, D. Balashov, SINIS Josephson junctions for programmable Josephson voltage standard circuits, *IEEE Trans. Appl. Supercond.* 9(2) (1999), pp. 4241–4244. DOI: [10.1109/77.783961](https://doi.org/10.1109/77.783961)
- [7] V. Lacquaniti, N. De Leo, M. Fretto, S. Maggi, A. Sosso, Nb/Al-AlO_x/Nb overdamped Josephson junctions above 4.2 K for voltage metrology, *Appl. Phys. Lett.* 91(25), (2007), art. No. 252505. DOI: [10.1063/1.2825469](https://doi.org/10.1063/1.2825469)
- [8] V. Lacquaniti, C. Cagliero, S. Maggi, R. Steni, D. Andreone, A. Sosso, RF properties of overdamped SIS junctions, *IEEE Trans. Appl. Supercond.* 15(2) (2005), pp. 114–116. DOI: [10.1109/TASC.2005.849707](https://doi.org/10.1109/TASC.2005.849707)
- [9] P. D. Dresselhaus, M. M. Elsbury, D. Olaya, C. J. Burroughs, S. P. Benz, 10 volt programmable Josephson voltage standard circuits using NbSi-barrier junctions, *IEEE Trans. Appl. Supercond.* 21(3) (2011), pp. 693–696. DOI: [10.1109/TASC.2010.2079310](https://doi.org/10.1109/TASC.2010.2079310)
- [10] H. Yamamori, M. Ishizaki, H. Sasaki, A. Shoji, Operating margins of a 10 V programmable Josephson voltage standard circuit using NbN/TiN_x/NbN/TiN_x/NbN double-junction stacks, *IEEE Trans. Appl. Supercond.* 17(2) (2007), pp. 858–863. DOI: [10.1109/TASC.2007.901444](https://doi.org/10.1109/TASC.2007.901444)
- [11] S. Benz, C. Hamilton, C. Burroughs, L. Christian, T. Harvey, AC and DC voltage source using quantized pulses, 1998 Conference on Precision Electromagnetic Measurements (CPEM 1998), Washington (USA), (1998), pp. 437–438. DOI: [10.1109/CPEM.1998.699991](https://doi.org/10.1109/CPEM.1998.699991)
- [12] P. Durandetto, D. Serazio, A. Sosso, Advancements in quantum voltage standards for time-dependent signals. Proceedings of 25th IMEKO TC4 International Symposium, Brescia, Italy, 2022, pp. 1-6. DOI: [10.21014/tc4-2022.04](https://doi.org/10.21014/tc4-2022.04)
- [13] C. Hamilton, C. Burroughs, R. Kautz, Josephson D/A converter with fundamental accuracy, *IEEE Trans. Instrum. Meas.* 44(2) (1995), pp. 223–225. DOI: [10.1109/19.377816](https://doi.org/10.1109/19.377816)
- [14] H. Yamamori, T. Yamada, H. Sasaki, A. Shoji, A 10 V programmable Josephson voltage standard circuit with a maximum output voltage of 20 V, *Supercond. Sci. Technol.* 21(10) (2008), art. No. 105007. DOI: [10.1088/0953-2048/21/10/105007](https://doi.org/10.1088/0953-2048/21/10/105007)
- [15] W.G. Ihlenfeld, The ac-ac transfer technique with subsampling. 2016 Conference on Precision Electromagnetic Measurements (CPEM 2016) (2016), pp. 212-214. DOI: [10.1109/CPEM.2016.7540771](https://doi.org/10.1109/CPEM.2016.7540771)
- [16] P. Durandetto, A. Sosso, A modular and customizable open-source package for quantum voltage standards operation and control, *PLOS ONE* 13(12) (2018), art. No. 0209246. DOI: [10.1371/journal.pone.0209246](https://doi.org/10.1371/journal.pone.0209246)
- [17] A. M. Klushin, J. Lesueur, M. Kampik, F. Raso, A. Sosso, S. K. Khorshev, N. Bergeal, F. Couëdo, C. Feuillet-Palma, P. Durandetto, M. Grzenik, K. Kubiczek, K. Musiol, A. Skorkowski, Present and future of high-temperature superconductor quantum-based voltage standards, *IEEE Instrum. Meas. Mag.* 23(2) (2020), pp. 4–12. DOI: [10.1109/MIM.2020.9062678](https://doi.org/10.1109/MIM.2020.9062678)
- [18] B. Trinchera, V. Lacquaniti, A. Sosso, M. Fretto, P. Durandetto, E. Monticone, On the synthesis of stepwise quantum waves using

- a SNIS programmable Josephson array in a cryocooler, *IEEE Trans. Appl. Supercond.* 27(4) (2017), pp. 1–5.
DOI: [10.1109/TASC.2016.2636569](https://doi.org/10.1109/TASC.2016.2636569)
- [19] V. Lacquaniti, N. De Leo, M. Fretto, A. Sosso, F. Muller, J. Kohlmann, 1 V programmable voltage standards based on SNIS Josephson junction series arrays, *Supercond. Sci. Technol.*, 24.4 (2011): 045004.
DOI: [10.1088/0953-2048/24/4/045004](https://doi.org/10.1088/0953-2048/24/4/045004)
- [20] P. Durandetto, A. Sosso, Non-conventional PJVS exploiting first and second steps to reduce junctions and bias lines, *IEEE Trans. Instrum. Meas.* 69(4) (2020), pp. 1294–1301.
DOI: [10.1109/TIM.2019.2913717](https://doi.org/10.1109/TIM.2019.2913717)
- [21] N. E. Flowers-Jacobs, A. Rüfenacht, A. E. Fox, S. B. Waltman, R. E. Schwall, J. A. Brevik, P. D. Dresselhaus, S. P. Benz., Development and applications of a four-volt Josephson arbitrary waveform synthesizer, 2019 IEEE International Superconductive Electronics Conference (ISEC), (2019), pp. 1–2.
DOI: [10.1109/ISEC46533.2019.8990937](https://doi.org/10.1109/ISEC46533.2019.8990937)
- [22] S. P. Benz, C. J. Burroughs, P. D. Dresselhaus, AC coupling technique for Josephson waveform synthesis, *IEEE Trans. Appl. Supercond.* 11(1) (2001), pp. 612–616.
DOI: [10.1109/77.919419](https://doi.org/10.1109/77.919419)
- [23] D. Kramer, Helium users are at the mercy of suppliers, *Phys. Today* 72(4) (2019), pp. 26–29.
DOI: [10.1063/PT.3.4181](https://doi.org/10.1063/PT.3.4181)
- [24] V. Lacquaniti, D. Andreone, N. D. Leo, M. Fretto, S. Maggi, A. Sosso, M. Belogolovskii, Analysis of the temperature stability of overdamped Nb/Al-AIO_x/Nb Josephson junctions, *IEEE Trans. Appl. Supercond.* 17(2) (2007), pp. 609–612.
DOI: [10.1109/TASC.2007.897389](https://doi.org/10.1109/TASC.2007.897389)
- [25] V. Lacquaniti, N. De Leo, M. Fretto, A. Sosso, M. Belogolovskii, Nb/Al-AIO_x/Nb superconducting heterostructures: a promising class of self-shunted Josephson junctions, *J. Appl. Phys.* 108(9) (2010), art. No. 093 701.
DOI: [10.1063/1.3503298](https://doi.org/10.1063/1.3503298)
- [26] V. Lacquaniti, M. Belogolovskii, C. Cassiago, N. De Leo, M. Fretto, A. Sosso, Universality of transport properties of ultrathin oxide films, *New J. Phys.* 14(2) (2012), p. 023025.
DOI: [10.1088/1367-2630/14/2/023025](https://doi.org/10.1088/1367-2630/14/2/023025)
- [27] V. Lacquaniti, N. De Leo, M. Fretto, C. Cassiago, R. Rocci, A. Sosso, M. Belogolovskii, Controlling the interface properties of submicrometric Nb/Al-AIO_x/Nb Josephson junctions, *IEEE Trans. Appl. Supercond.* 25(3) (2015), pp. 1–4.
DOI: [10.1109/TASC.2014.2367232](https://doi.org/10.1109/TASC.2014.2367232)
- [28] M. Belogolovskii, E. Zhitlukhina, V. Lacquaniti, N. De Leo, M. Fretto, A. Sosso, Intrinsically shunted Josephson junctions for electronics applications, *Low Temp. Phys.* 43(7) (2017), pp.756–765.
DOI: [10.1063/1.4995622](https://doi.org/10.1063/1.4995622)
- [29] V. Lacquaniti, C. Cassiago, N. D. Leo, M. Fretto, A. Sosso, P. Febvre, V. Shaternik, A. Shapovalov, O. Suvorov, M. Belogolovskii, P. Seidel, Analysis of Internally Shunted Josephson Junctions, *IEEE Trans. Appl. Supercond.* 26(3) (2016), pp. 1–5.
DOI: [10.1109/TASC.2016.2535141](https://doi.org/10.1109/TASC.2016.2535141)
- [30] V. Lacquaniti, D. Andreone, N. De Leo, M. Fretto, A. Sosso, M. Belogolovskii, Engineering overdamped niobium-based Josephson junctions for operation above 4.2 K, *IEEE Trans. Appl. Supercond.* 19(3) (2009), pp. 234–237.
DOI: [10.1109/TASC.2009.2019072](https://doi.org/10.1109/TASC.2009.2019072)
- [31] D. Zhao, H. E. van den Brom, E. Houtzager, Mitigating voltage lead errors of an AC Josephson voltage standard by impedance matching, *Meas. Sci. Technol.* 28(9) (2017), art. No. 095004.
DOI: [10.1088/1361-6501/aa7aba](https://doi.org/10.1088/1361-6501/aa7aba)
- [32] J. M. Underwood, Uncertainty analysis for ac–dc difference measurements with the ac Josephson voltage standard, *Metrologia* 56(1) (2018), art. No. 015012.
DOI: [10.1088/1681-7575/aaf5e5](https://doi.org/10.1088/1681-7575/aaf5e5)
- [33] A. Sosso, P. Durandetto, B. Trinchera, O. Kieler, R. Behr, J. Kohlmann, Characterization of a Josephson array for pulse-driven voltage standard in a cryocooler, *Measurement* 95 (2017), pp. 77–81.
DOI: [10.1016/j.measurement.2016.09.039](https://doi.org/10.1016/j.measurement.2016.09.039)
- [34] F. Overney, Y. Pimsut, S. Bauer, O. Kieler, R. Behr, B. Jeanneret, Load compensation bridge for Josephson arbitrary waveform synthesizers. *Meas. Sci. Technol.* 31(5) (2020), art. no. 055004.
DOI: [10.1088/1361-6501/ab62c7](https://doi.org/10.1088/1361-6501/ab62c7)
- [35] A. Sosso, P. Durandetto, R. Behr, O. Kieler, Towards mitigation of cable-loading effect with a cryocooled pulse-driven Josephson standard, 2018 Conference on Precision Electromagnetic Measurements (CPEM 2018), Paris (France), (2018), pp. 1–2.
DOI: [10.1109/CPEM.2018.8501217](https://doi.org/10.1109/CPEM.2018.8501217)
- [36] A. Sosso, P. Durandetto, Experimental analysis of the thermal behavior of a GM cryocooler based on linear system theory, *Int. J. Refrig.* 92 (2018), pp. 125–132.
DOI: [10.1016/j.ijrefrig.2018.04.016](https://doi.org/10.1016/j.ijrefrig.2018.04.016)
- [37] A. Sosso, P. Durandetto, Determination of the temperature vs power dynamic behavior of a cryocooler via two independent methods in time and frequency domain. *MethodsX* 5 (2018), pp. 841–847.
DOI: [10.1016/j.mex.2018.06.013](https://doi.org/10.1016/j.mex.2018.06.013)
- [38] A. Sosso, P. Durandetto, Data of cryocooler temperature dynamical response to time-varying power inputs at 4 K. *Data in brief* 20 (2018), pp. 1468–1470.
DOI: [10.1016/j.dib.2018.08.211](https://doi.org/10.1016/j.dib.2018.08.211)
- [39] P. Durandetto, E. Monticone, D. Serazio, A. Sosso, Thermal performances of an improved package for cryocooled Josephson standards, *IEEE Trans. Compon. Packag. Manuf. Technol.* 9(7) (2019), pp. 1264–1270.
DOI: [10.1109/TCPMT.2019.2901297](https://doi.org/10.1109/TCPMT.2019.2901297)
- [40] P. Durandetto, A. Sosso, Using a Josephson junction as an effective on-chip temperature sensor, *Supercond. Sci. Technol.* 34(4) (2021), art. No. 045008.
DOI: [10.1088/1361-6668/abdccc](https://doi.org/10.1088/1361-6668/abdccc)
- [41] R. Souza, R. Afonso Jr, M. Klonz, R. Landim, New generation of AC-DC current transfer standards at Inmetro, *Acta IMEKO* 1(1) (2012), pp. 65–69.
DOI: [10.21014/acta_imeko.v1i1.24](https://doi.org/10.21014/acta_imeko.v1i1.24)