



ISTITUTO NAZIONALE DI RICERCA METROLOGICA Repository Istituzionale

Qualification of free-field environments: a case study

Original

Qualification of free-field environments: a case study / Saba, F.; Durando, G.; Corallo, M.. - (2022). (24th International Congress on Acoustics (ICA 2022) Gyeongju, Corea del Sud 24-28 Ottobre 2022).

Availability:

This version is available at: 11696/76141 since: 2025-03-04T09:24:48Z

Publisher:

Published

DOI:

Terms of use:

This article is made available under terms and conditions as specified in the corresponding bibliographic description in the repository

Publisher copyright

(Article begins on next page)

ABS-0639

Qualification of free-field environments: a case study

Fabio SABA¹; Giovanni DURANDO; Mario CORALLO

¹INRIM, Istituto Nazionale di Ricerca Metrologica, Turin, Italy

ABSTRACT

Qualification of anechoic and hemi-anechoic chambers is intended to demonstrate that the test environment adequately supports free sound field conditions (anechoic spaces), or free sound field conditions over a reflecting plane (hemi-anechoic spaces). According to the ISO 26101:2017, free-field performances are evaluated by comparing the reduction of sound pressure levels measured along specified traverse paths starting from a test sound source, against the theoretical reduction evaluated by the inverse square law. In order to detect the contributions due to reflected components of acoustic energy, the ISO 26101:2017 requires a high spatial resolution of measurement points inside the test environment, resulting in a significant increase in experimental effort and time. The present paper describes a case study concerning the qualification of a hemi-anechoic chamber according to the ISO 26101:2017. Key issues related to the realization of an automatic system for the microphone positioning along the traverse paths, the operation of the test sound source, the acquisition and analysis of measurement data are presented and discussed.

Keywords: hemi-anechoic chamber, qualification, free field environment

1. INTRODUCTION

The International Standard ISO 26101:2017 (1) specifies the test methods for the qualification of free-field environments, i.e. the assessment of the performance of anechoic and hemi-anechoic space in realizing free-field conditions. In particular, performances of free-field environments are evaluated by comparing the reduction of sound pressure levels measured along specified traverse paths starting from a test sound source, against the ideal reduction evaluated by the inverse square law. To evaluate whether a space can be considered anechoic or not, deviations from such an ideal attenuation of sound pressure levels should not exceed the maximum allowable deviations specified by the ISO 26101:2017 Standard, in the frequency range of interest.

To properly detect both direct and reflected components of acoustic energy, occurring in real free-field environment, the ISO 26101:2017 Standard requires the sound pressure levels to be measured with high spatial resolution, particularly at higher frequencies, where the spacing between measurement points along traverse path should not exceed 25 mm at frequency above 1 kHz. This means a significant increase of experimental effort and time, especially for large environments, also considering the typical frequency range of interest, usually from 100 Hz to 10 kHz at least, according with the typical spectral characteristics of the sound sources evaluated in free-field environments.

In this work, we describe an automatic measurement system realized for the implementation of the qualification procedure specified by the ISO 26101:2017 Standard, and the results related to a case study.

2. AN AUTOMATIC MEASUREMENT SYSTEM FOR QUALIFICATION TESTS

In this Section, we briefly describe the automatic measurement system realized for the purpose of qualification of hemi-anechoic chambers, according with the ISO 26101:2017 Standard.

2.1 Microphone positioning system

The system basically consists of a remote-controlled stepper motor, which pulls the measurement microphone along the traverse paths by means of tensioned cables, and ensures its accurate positioning through a closed-loop control provided by the encoder feedback. This system, in view of the high

¹ f.saba@inrim.it

spatial resolution of measurement points, considerably reduces measurement times and eliminates the uncertainty contributions associated with manual microphone positioning.

In Figure 1, the sliding supports realized for moving the measurement microphone along the traverse paths are sketched. The supports are fixed to a carbon rod, which is fixed, in turn, to the microphone, extending its length. The system slides along two parallel tensioned cables, which define the traverse path. In this way, the weight of the microphone and its signal cable is better distributed on the tensioned traverse cables, facilitating the realization of straight traverse paths.

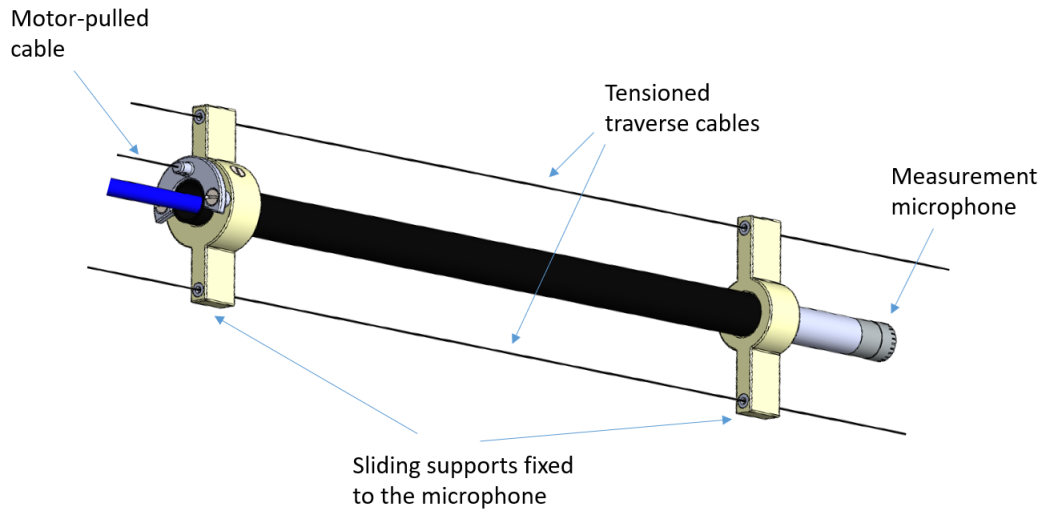

Figure 1 – Measurement microphone support and traverse cables

A pulley located at the end of the traverse paths, suspended from a proper support, acts as a guide for the cables and allows them to be easily tensioned at floor level (Figure 2).

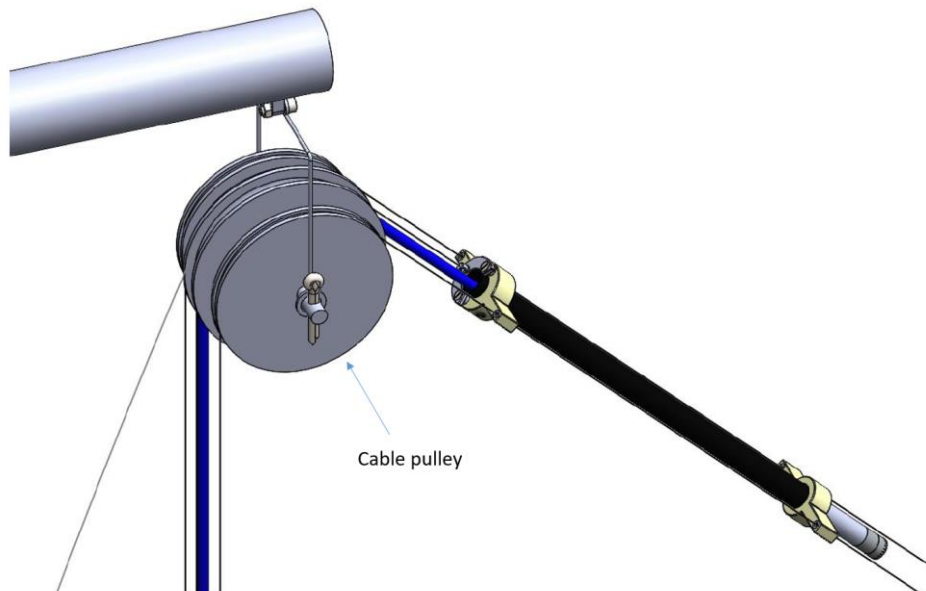

Figure 2 – Tensioned cable system for microphone motion along the traverse path

2.2 Test sound source

A key issue in the qualification of free-field environments, is the selection of a proper sound source able to ensure, in the frequency range of interest, a sound radiation with uniform directionality, and a sufficient sound power in order to yield sound pressure levels at the measurement points at least 6 dB above the background noise. Furthermore, it should approximate a point source, and be located as

close as possible to the reflecting surface (floor of hemi-anechoic chamber), at most, at one tenth of the wavelength of the maximum frequency in the range of interest. To this end, a sound source consisting of a dual cone full-range loudspeaker has been coupled by means of a pyramid-shaped wooden cavity to a 2 m length tube (35 mm diameter) serving as acoustic wave-guide, which ends with a 90° elbow, with a 6 mm diameter opening, faced to the reflecting surface of the chamber. The pyramid-shaped wooden cavity is inserted into an MDF wooden box stuffed with glass wool, and the wave-guide tube is externally coated with damping material, to ensure the sound to be emitted from the 6 mm tube opening only. The wave-guide tube directs the sound towards the floor plane of the chamber, so that the image source resulting from sound reflection is exploited. The stability of the sound power emitted by the source is taken into account by means of a monitor microphone, placed in a fixed position in the chamber.

To improve the signal-to-noise ratio, the sound source is driven by a linear sweep signal, ensuring a sufficient integration time for the FFT analyzer, over each one third-octave frequency band. The acoustic spectrum analyzer used for the measurement of sound pressure levels and the source signal generation, is the Ono Sokki DS-3000, which ensures the synchronization between microphone signals acquisition and source signal generation.

2.3 Measurement data analysis

Once sound pressure levels are measured along each traverse path, the post-processing of measurement data allows maximizing the qualified distance from the test sound source, in which the deviations ΔL_{pi} of measured sound pressure levels with respect to the ideal inverse square law are within the tolerance range. To this aim, the so-called source strength parameter b , i.e. the sound pressure level at the reference distance $r_0 = 1$ m from the mathematical origin of the traverse, should be determined by an iterative process, and the sound pressure level $L_p(r_i)$ based on the inverse square law at the distance r_i from the mathematical origin of the traverse is calculated as:

$$L_p(r_i) = b - 20 \log_{10}(r_i/r_0) \quad (1)$$

The proper evaluation of the source strength parameter b is fundamental to maximize the distance in which a space can be considered anechoic. An iterative process can be adopted to find the optimal value of b that allows most of the measurement points to fall within the tolerance range. A good starting value is given by the ISO 26101:2017 Standard, which represents the mean value of the sound pressure levels calculated by inverse square law extrapolation of sound pressure levels measured at the different positions along the traverse path. The optimal value of b can be searched iteratively, by identifying the larger subset of consecutive measurement points along the traverse path and the wider frequency range, characterized by deviations from the ideal sound pressure levels all within the tolerance range.

3. RESULTS OF A CASE STUDY

In this section, we report an example of the qualification results obtained during the test of the measurement system described in Section 2, in a hemi-anechoic chamber.

In Figure 3, the qualification results are shown in terms of deviations ΔL_{pi} of measured sound pressure levels with respect to the ideal inverse square law, at each one third-octave frequency band from 100 Hz to 10 kHz, and at each measurement position r along a specific traverse path (r is the distance from the mathematical origin of the traverse path). The tolerance band specified by the ISO 26101:2017 Standard is also reported. It can be observed that some measurement points, at the end and at the beginning of the traverse path, are outside the tolerance band, for specific frequencies in the range of interest. This may be due to the effect of reflected components of acoustic energy that characterize the environment under test, and to the near field acoustic conditions in proximity of the source.

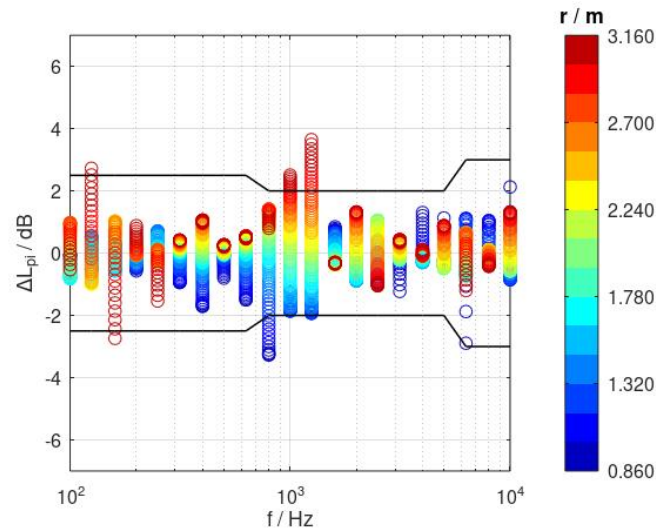

Figure 3 – Deviations from the inverse square law for a specific traverse path

In order to evaluate the maximum qualified distance that satisfies the free-field requirements, the optimal value of the source strength parameter b has been determined according with the procedure described in Section 2.3, and the actual limits of the qualified space have been assessed. The final results of the qualification are shown in Figure 4. Along the specific traverse path, the environment satisfies the free-field requirements from 1.985 m to 3.135 m with respect to the mathematical origin of the traverse.

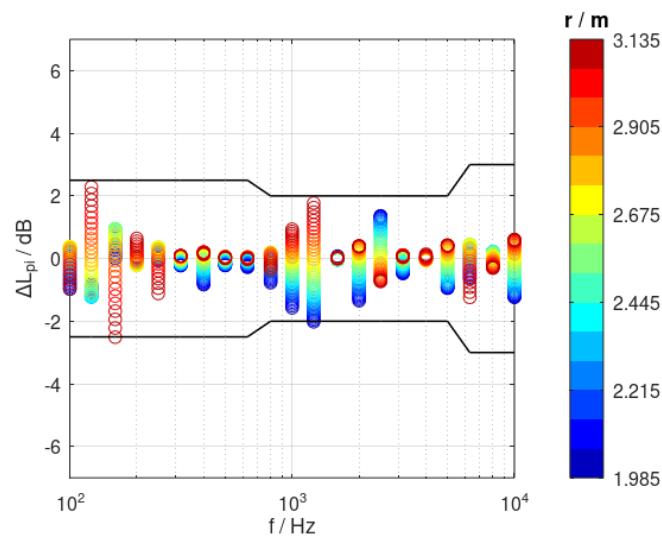

Figure 4 – Deviations from the inverse square law for a specific traverse path, along the qualified distance

4. CONCLUSIONS

The measurement system presented in this work for the qualification of free-field environments according to the ISO 26101:2017 Standard, allows the coherent operation between the signal acquisition system and the sound generation, and together with the above-mentioned microphone positioning apparatus, ensures the qualification procedure to be effectively automated.

REFERENCES

1. ISO 26101:2017. Acoustics - Test methods for the qualification of free-field environments (ISO, Switzerland).